

TOOLS REQUIRED / OUTILS REQUIS

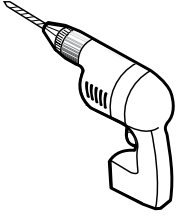

DRILL
PERCEUSE

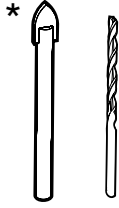

1/4" & 1/8" DRILL BITS
MÈCHE 1/4" & 1/8"



SCREWDRIVER
TOURNEVIS

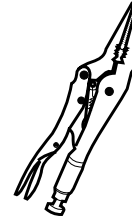

LONG NOSE LOCKING PLIERS (X2)
PINCE SERRE ÉTAU (X2)

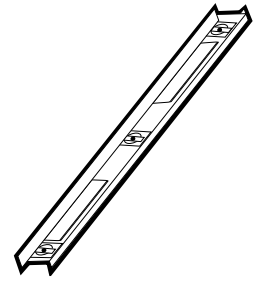

LEVEL
NIVEAU



PENCIL
CRAYON

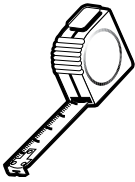

TAPE MEASURE
RUBAN À MESURER

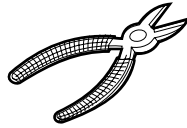

CUTTING PLIERS
PINCE COUPANTE



MALLET
MAILLET

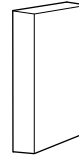

BLOCK
BLOC

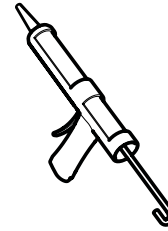

SILICONE
SCÉLLANT

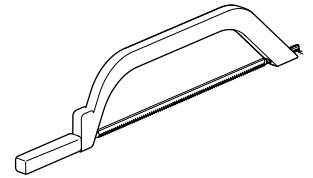

HACKSAW
SCIE À MÉTAUX

* Use a 1/4" drill bit when drilling into ceramic tiles

* Utiliser une mèche de 1/4" pour percer des tuiles en céramique.

POSSIBLE CONFIGURATIONS / CONFIGURATIONS POSSIBLES

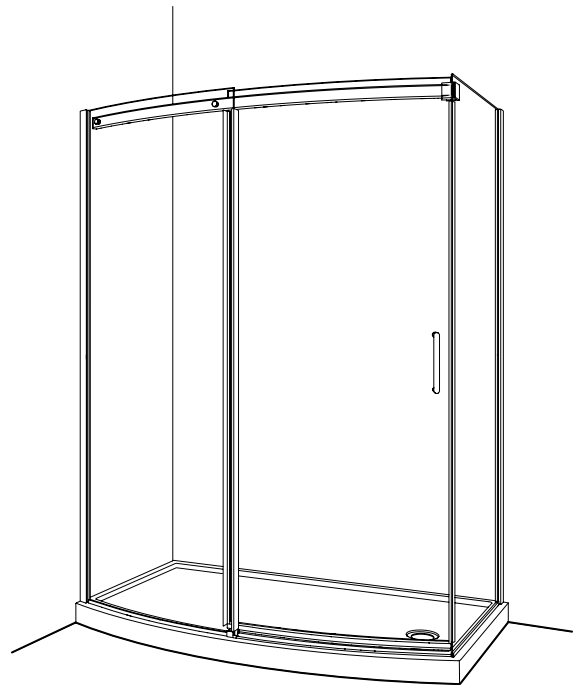

* This configuration illustrated in this manual.

* Cette configuration est illustrée dans ce manuel.

PARTS LISTING / LISTE DES PIÈCES

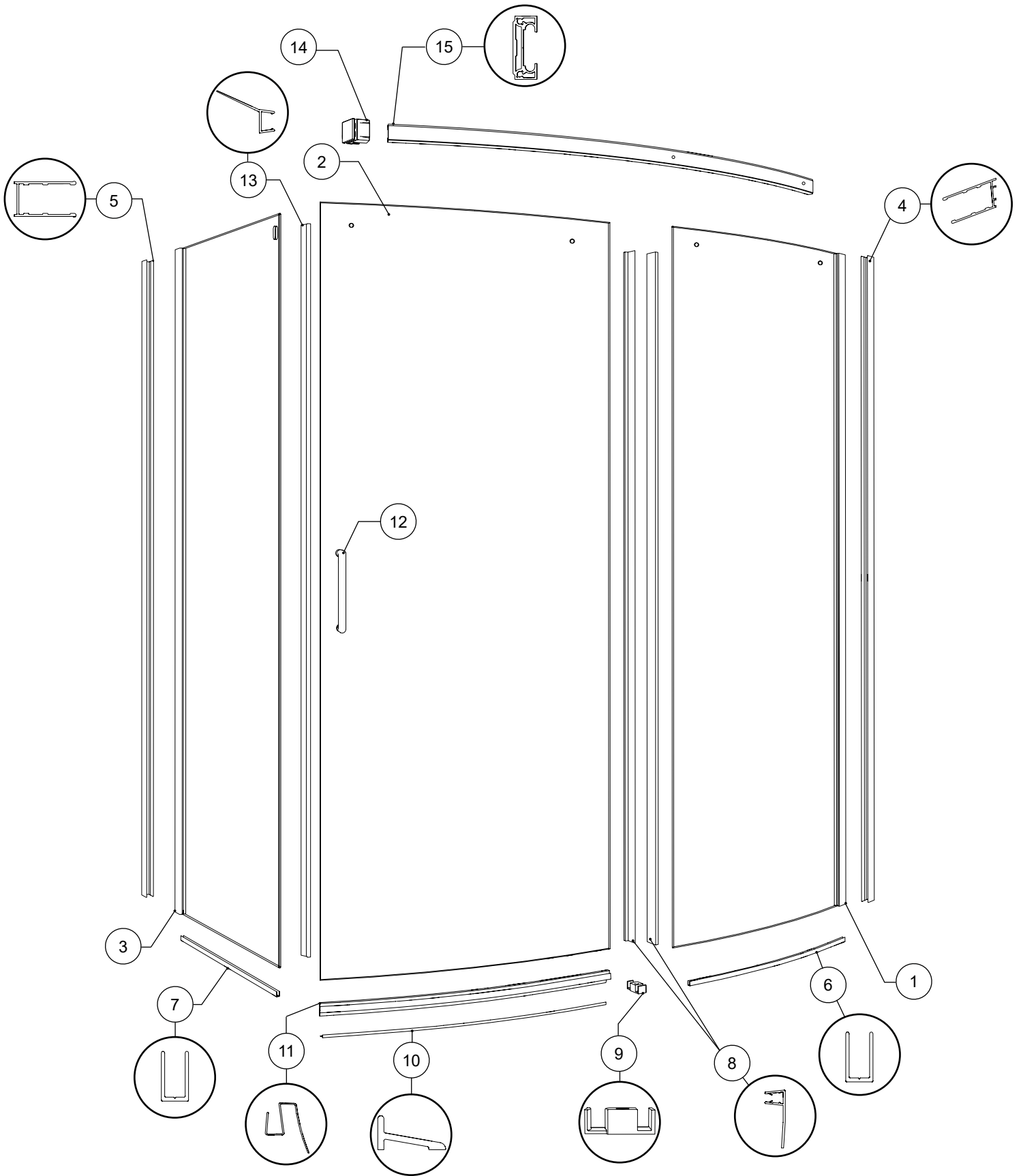

PARTS LISTING / LISTE DES PIÈCES

ITEM	PARTS LISTING / LISTE DES PIÈCES	QTY
1	FIXED PANEL / PANNEAU FIXE	1
2	DOOR PANEL / PANNEAU DE PORTE	1
3	RETURN PANEL / PANNEAU DE RETOUR	1
4	WALL JAMB FOR FIXED PANEL / JAMBAGE POUR PANNEAU FIXE	1
5	WALL JAMB FOR RETURN PANEL / JAMBAGE POUR PANNEAU DE RETOUR	1
6	U-CHANNEL FOR FIXED PANEL / PROFILÉ EN "U" POUR PANNEAU FIXE	1
7	U-CHANNEL FOR RETURN PANEL / PROFILÉ EN "U" POUR PANNEAU DE RETOUR	1
8	SIDE GASKET / JOINT LATÉRAL DE LA PORTE	2
9	BOTTOM GUIDE / GUIDE INFÉRIEUR	1
10	THRESHOLD / SEUIL	1
11	BOTTOM DOOR GASKET / JOINT INFÉRIEUR DE LA PORTE	1
12	DOOR HANDLE / POIGNÉE DE PORTE	1
13	SIDE DOOR GASKET / JOINT LATÉRAL DE LA PORTE	1
14	WALL MOUNT BRACKET / SUPPORT MURAL	1
15	RUNNING RAIL / BARRE DE ROULEMENT	1
ITEM	HARDWARE LISTING / LISTE DE QUINCAILLERIE	QTY
16	RAIL CAP / CAPUCHON DE RAIL	1
17	THRESHOLD ANCHOR / L'ANCRAGE DU SEUIL	1
18	WALL PLUG / CHEVILLE	6
19	CLEAR SETTING BLOCK (1/16") / BLOC À NIVEAU TRANSPARENT (1/16")	4
20	CLEAR SETTING BLOCK (1/8") / BLOC À NIVEAU TRANSPARENT (1/8")	4
21	WHEEL / ROULETTE	2
22	WHEEL CAP / CAPUCHON DE ROULETTE	2
23	FASTENER / FIXATION DE VERRE	2
24	KEY / CLÉ	2
25	PAN HEAD SCREW / VIS À TÊTE PLATE	7
26	SCREW / VIS	2
27	PAN SELF-DRILLING SCREW / VIS PAN AUTO-PERÇANTE	6
28	SCREW CAP / CAPUCHON COUVRE-VIS	6
29	BOTTOM GUIDE CAP / CAPUCHON DU GUIDE INFÉRIEUR	1
30	BACK SCREW CAP / L'ARRIÈRE DU CAPUCHON COUVRE-VIS	6

PARTS LISTING / LISTE DES PIÈCES

