

TOOLS AND MATERIAL REQUIRED / OUTILS ET MATÉRIAUX REQUIS

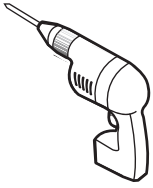

DRILL
PERCEUSE

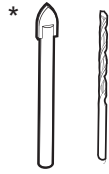

1/4" & 1/8" DRILL BITS
MÈCHE 1/4" & 1/8"



SCREWDRIVERS
TOURNEVIS

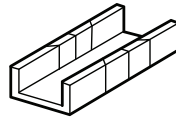

MITER BOX
BOÎTE À ONGLETS



WRENCH
CLÉ ANGLAISE



MASKING TAPE
RUBAN DE MASQUAGE

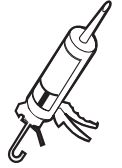

SILICONE
SCÉLLANT



PENCIL
CRAYON

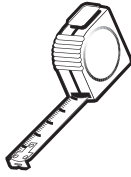

TAPE MEASURE
RUBAN À MESURER



MALLET
MAILLET

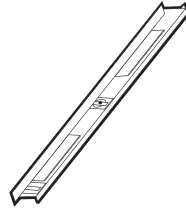

LEVEL
NIVEAU

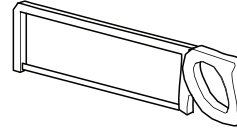

HACKSAW WITH 32 TEETH PER INCH BLADE
SCIE À MÉTAUX AVEC 32 DENTS PAR POUCE PAR LAME



SAFETY GLASSES
LUNETTES DE SÉCURITÉ

* Use a 1/4" drill bit for ceramic when drilling into ceramic tiles

* Utiliser une mèche de 1/4" destiné à céramique lors du perçage des tuiles en céramique.

DETECTING THE SEKUR SIDE ON THE GLASS / DÉTECTER LE CÔTÉ SEKUR SUR LE VERRE

The panels are treated differently on each side. Locate the SEKUR label that is installed on the INTERIOR side of the shower. Remove the sticker at the end of the installation.

Les panneaux ont un traitement différent sur chaque côté. Localiser l'étiquette SEKUR qui est installée sur la face INTÉRIEURE de la douche. Retirer l'étiquette à la fin de l'installation.

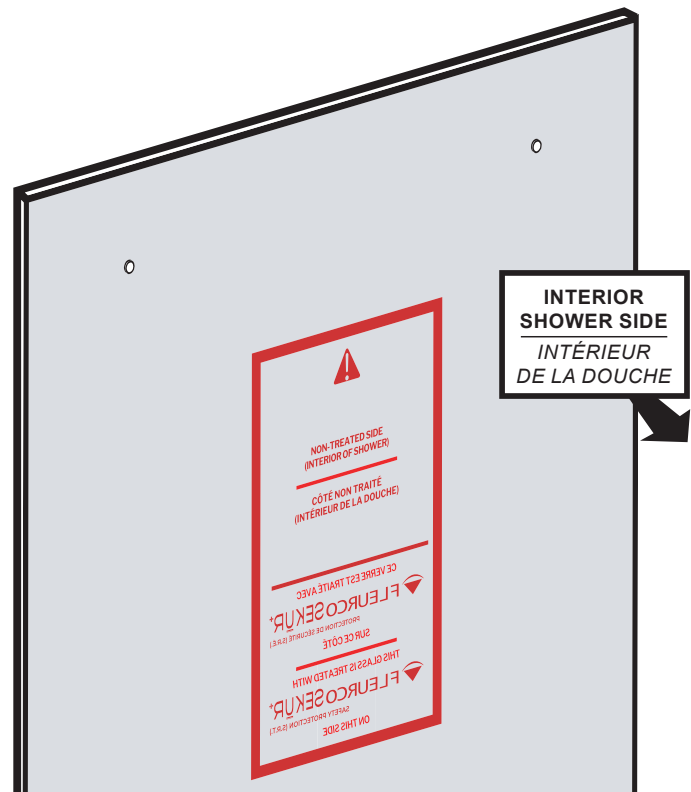

POSSIBLE CONFIGURATIONS / CONFIGURATIONS POSSIBLES

SHOWER / DOUCHE

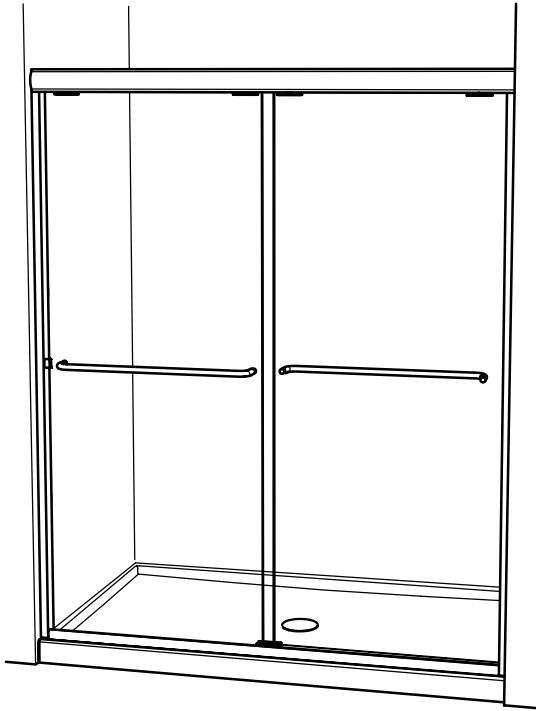

TUB / BAIN

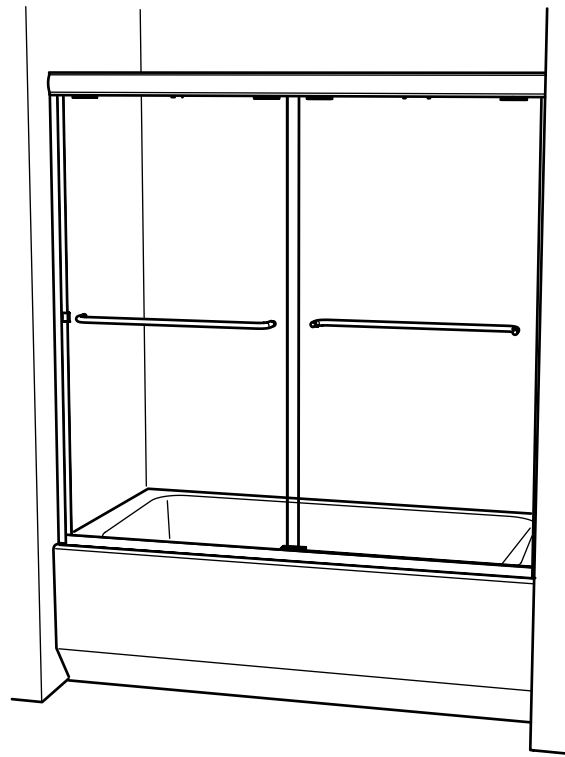

*

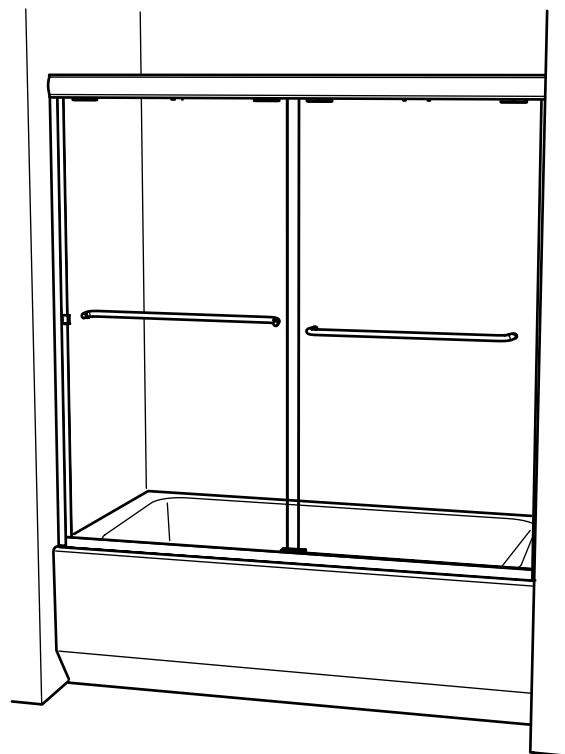

*** This configuration is illustrated in this manual.**

** Cette configuration est illustrée dans ce manuel.*

PARTS LISTING / LISTE DES PIÈCES

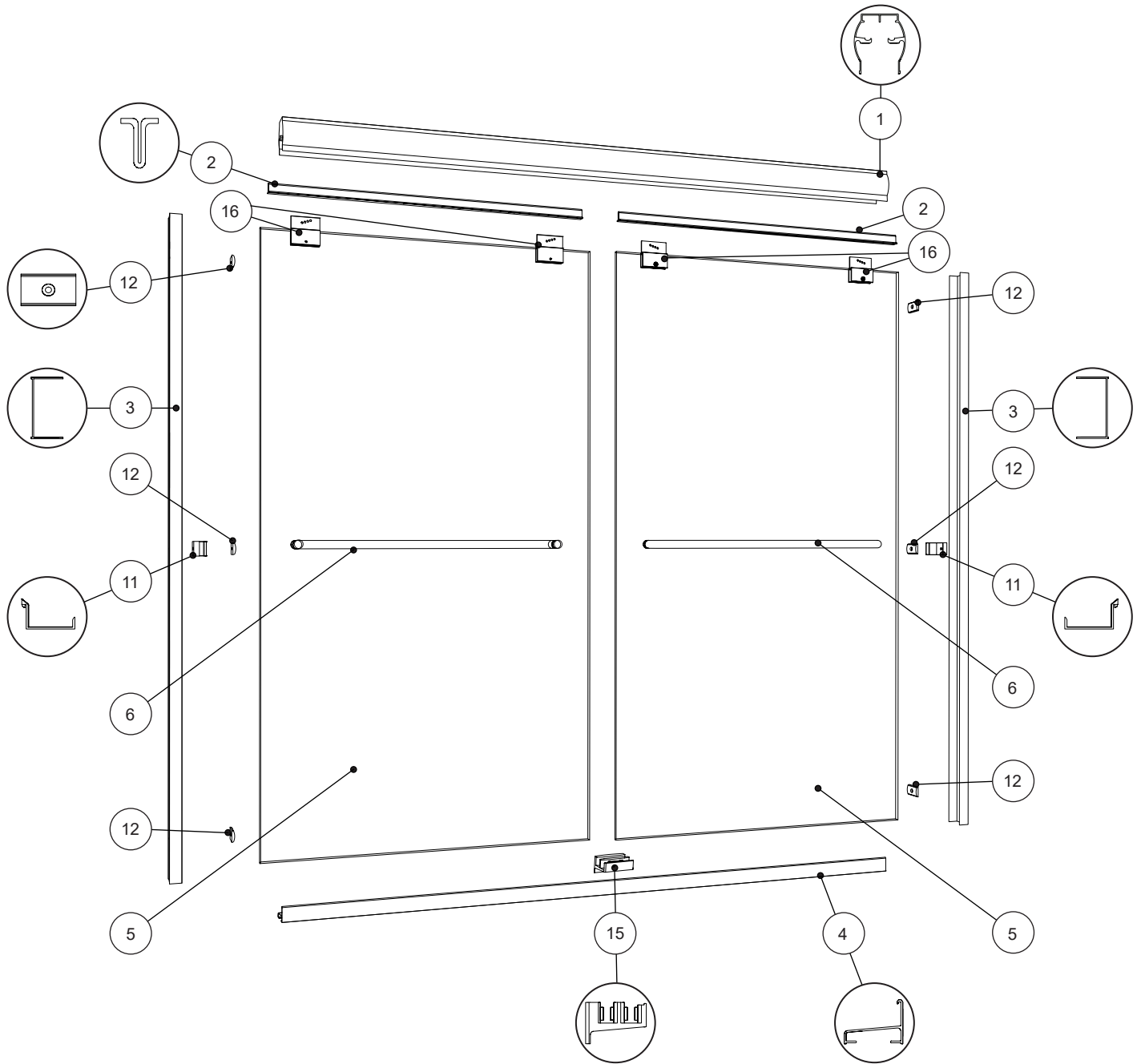

PARTS LISTING / LISTE DES PIÈCES

ITEM	PARTS LISTING / LISTE DES PIÈCES	CODE	QTY
1	TOP RAIL / RAIL SUPÉRIEUR	COR-TRAIL-60-XX	1
2	ANTI-JUMP / ANTI-SAUT	COR-ANTIJUMP-33-36	2
3	WALL JAMB / JAMBAGE	COR-WJAMB-75-XX	2
4	BOTTOM RAIL / RAIL INFÉRIEUR	COR-BRAIL-60-XX	1
5	GLASS PANEL / PANNEAU EN VERRE		2
6	HANDLE BAR / POIGNÉE	COR-HANDLEBAR-16-XX *COR-HANDLEBAR-24-XX	2
ITEM	HARDWARE LISTING / LISTE DE QUINCAILLERIE	CODE	QTY
7	WHEELS / ROUES	COR-ROLLER	4
8	PAN HEAD MACHINE SCREW #8 - 3/8" / VIS PAN #8 - 3/8"		4
9	PAN SCREW #8 - 1 1/2" / VIS PAN #8 - 1 1/2"		6
10	PAN SCREW #8 - 3/8" / VIS PAN #8 - 3/8"		1
11	SIDE GUIDE / GUIDE LATÉRAUX	COR-SG-XX	2
12	BUMPER / BUTOIR	**COR-BUMPER	6
13	KEY / CLÉ		1
14	WALL PLUG / CHEVILLE		7
15	CENTER GUIDE / GUIDE CENTRAL	COR-BGUIDE-6MM-XX	1
16	ROLLER BRACKET / SUPPORT DE ROULEAU	**COR-ROLLER-BRACKET-6	4

COR-HRDBAG

*For 60" model only / Pour le modèle de 60po seulement

**Add -33 for black / Ajouter -33 pour noir

HARDWARE LISTING / LISTE DE QUINCAILLERIE

