

INSTRUCTION MANUAL - GUIDE D'INSTALLATION

P218

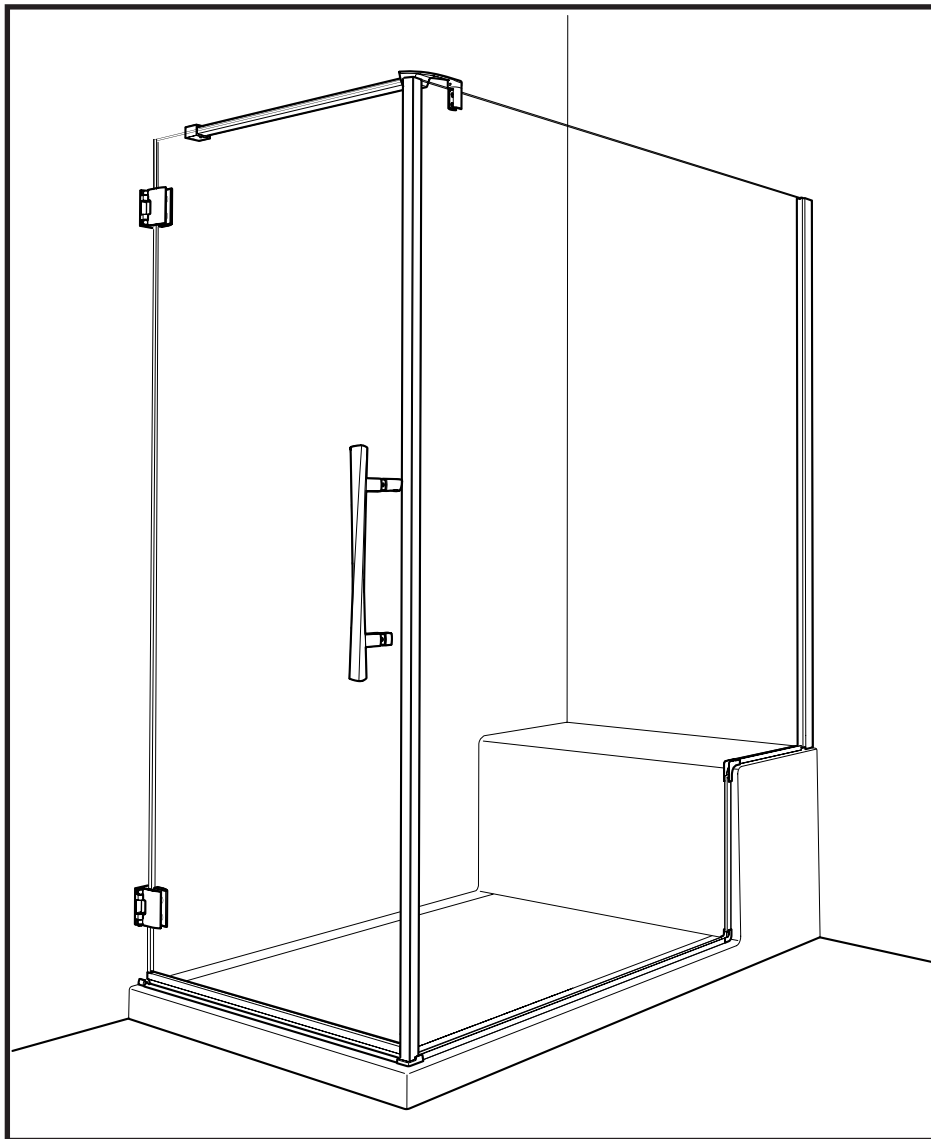

08 / 2018

Please keep this manual and product code number for future reference and for ordering replacement parts if necessary.

Veillez conserver ce manuel et le code de produit pour des références futures, et au besoin, la commande de pièces de rechange.

GENERAL INSTRUCTIONS

- Read this manual carefully and completely before proceeding.
- It is recommended that you wear safety glasses at all times during the installation.

En

INSTALLATION OVER CERAMIC TILES

- If your shower door is to be installed over ceramic tiles, the tiles should lay completely under the wall jamb.
- Silicone should be used to seal the gap where the ceramic tiles meet the fixed panel.

NOTICE

- Caulking: no sealant is required inside the shower, unless otherwise stated.
- Some models are equipped with clear sealing gaskets.

CARE FOR YOUR SHOWER DOOR

- Never use scouring powder pads or sharp instruments on metal pieces or glass panels. An occasional wiping down with a mild soap diluted in water is all that is needed to keep the panels and aluminum parts looking new.
- We recommend wiping the glass panels with a squeegee after each use.

INSTRUCTIONS GÉNÉRALES

- Lire attentivement et complètement le manuel d'installation avant de procéder.
- Il est recommandé de porter des lunettes de sécurité en tout temps lors de l'installation.

Fr

INSTALLATION SUR LES TUILES EN CÉRAMIQUE

- Si votre porte de douche doit être installée sur une bordure en céramique, le jambage doit reposer complètement sur cette dernière.
- Le calfeutrage doit être appliqué sur le côté extérieur de la douche où le panneau fixe rencontre la bordure en céramique.

NOTE

- Calfeutrage: aucun scellant n'est nécessaire à l'intérieur de la douche.
- Certains modèles sont dotés de joints d'étanchéité clairs.

L'ENTRETIEN DE VOTRE DOUCHE

- Ne jamais utiliser de poudre ou de tampon à récurer, ni d'instrument tranchant sur les parties en métal ou en verre. De temps à autre, il suffit de nettoyer la porte avec une solution d'eau et un détergent doux pour conserver l'aspect neuf des panneaux de verre et du cadre en aluminium.
- Nous recommandons de passer une raclette de douche sur les panneaux de verre après chaque utilisation.

TOOLS REQUIRED / OUTILS REQUIS

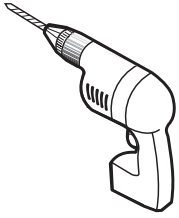

DRILL
PERCEUSE

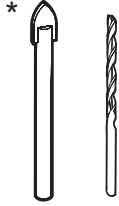

1/4" & 1/8" DRILL BITS
MÈCHE 1/4" & 1/8"



LONG NOSE LOCKING PLIERS (X2)
PINCE SERRE ÉTAU (X2)



SCREWDRIVER
TOURNEVIS

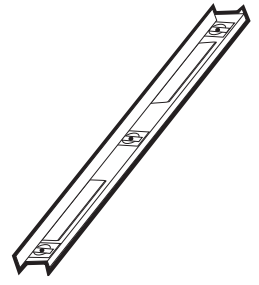

LEVEL
NIVEAU



PENCIL
CRAYON

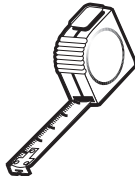

TAPE MEASURE
RUBAN À MESURER

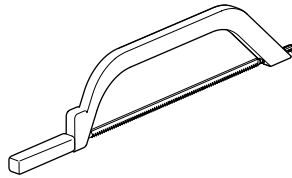

HACKSAW
SCIE À MÉTAUX

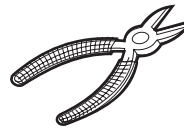

CUTTING PLIERS
PINCE COUPANTE



MALLET
MAILLET

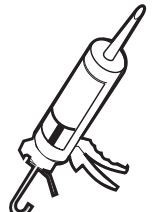

SILICONE
SCELLANT

* Use a 1/4" drill bit for ceramic when drilling into ceramic tiles

* Utiliser une mèche de 1/4" destiné à céramique lors du perçage des tuiles en céramique.

POSSIBLE CONFIGURATIONS / CONFIGURATIONS POSSIBLES

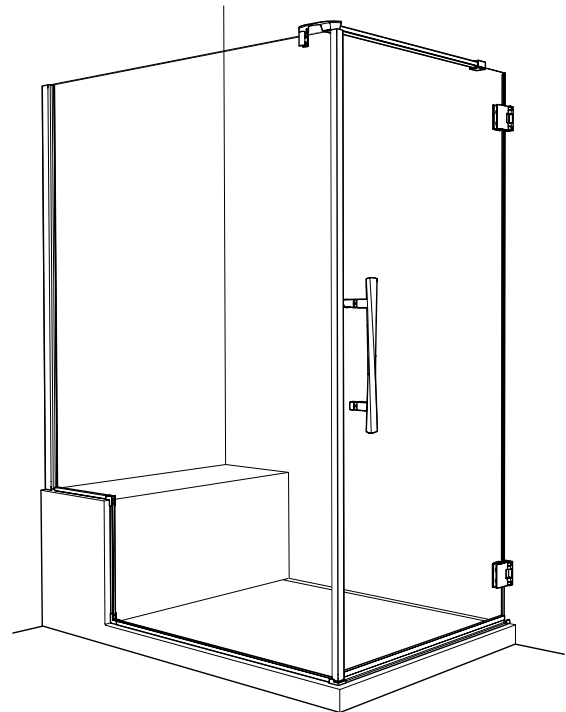
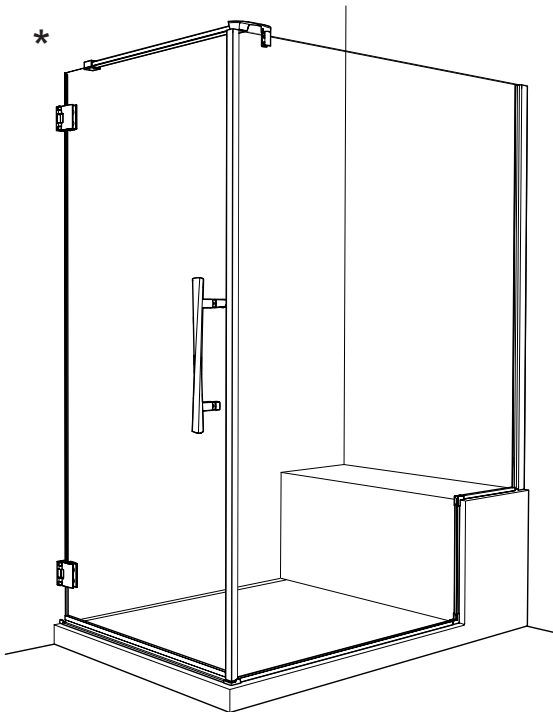

* This configuration and BSSU3660 base is illustrated in this manual.
The same configurations are possible with the ABAL3660 base.

* Cette configuration avec la base BSSU3660 est illustrée dans ce manuel.
Les mêmes configurations avec la base ABAL3660 sont possibles.

PARTS LISTING / LISTE DES PIÈCES

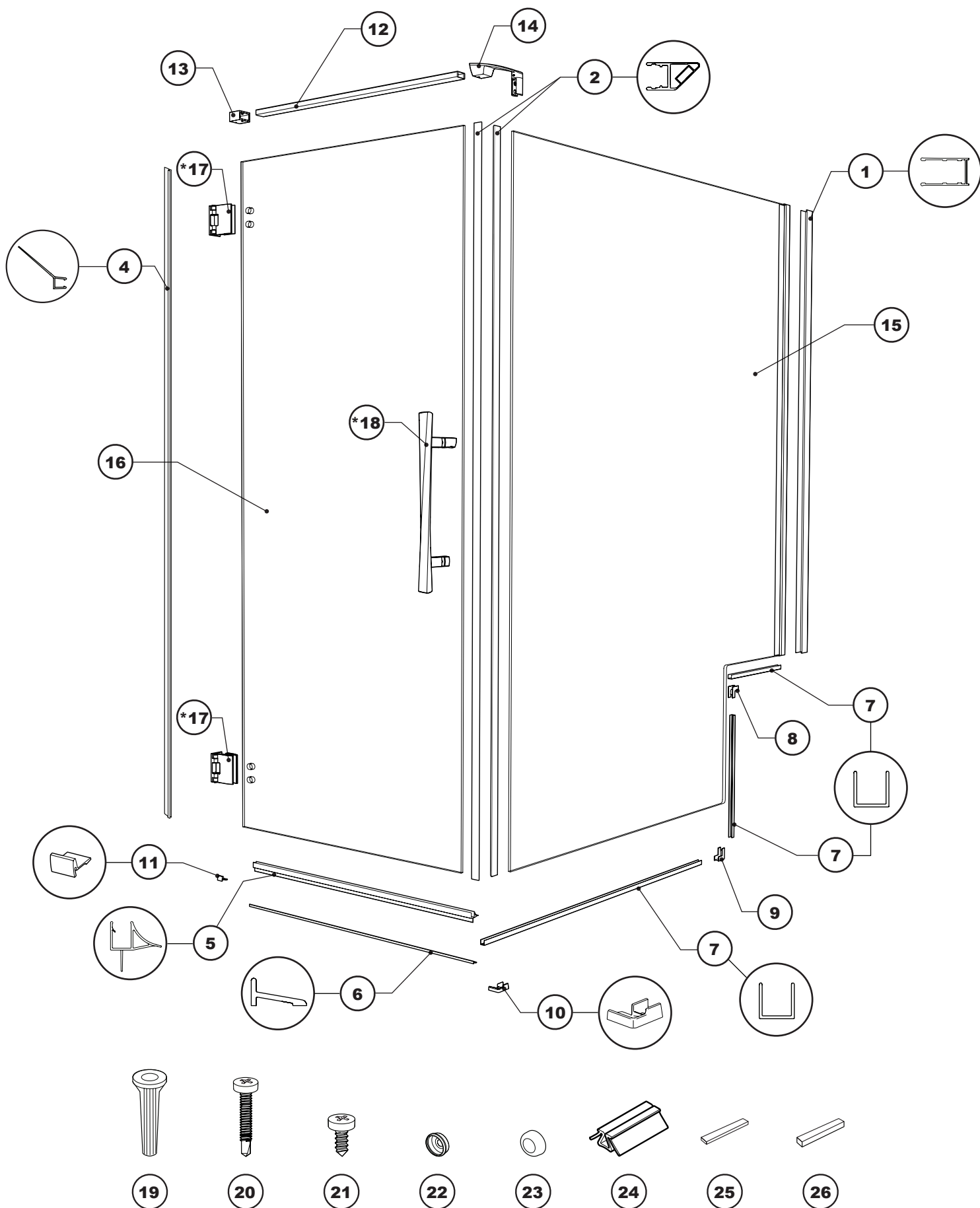

PARTS LISTING / LISTE DES PIÈCES

ITEM	PARTS LISTING / LISTE DES PIÈCES	QTY
1	WALL JAMB / JAMBAGE	1
2	MAGNETIC GASKET / JOINT MAGNÉTIQUE	2
4	SIDE GASKET / JOINT LATÉRAL	1
5	BOTTOM DOOR GASKET / JOINT INFÉRIEUR DE LA PORTE	1
6	THRESHOLD / SEUIL	1
7	U-CHANNEL (short, medium, and long) / PROFILÉ EN «U» (court, mi-long, et long)	3
8	TOP ELBOW / COUDE SUPÉRIEUR	1
9	BOTTOM ELBOW / COUDE INFÉRIEUR	1
10	THRESHOLD CORNER ANCHOR / ANCRAGE DU SEUIL DE COIN	1
11	THRESHOLD ANCHOR END / ANCRAGE LATÉRAL DU SEUIL	1
12	SUPPORT BAR / BARRE DE SUPPORT	1
13	WALL MOUNT BRACKET / SUPPORT MURAL	2
14	GLASS MOUNT BRACKET / SUPPORT DE VERRE	1
15	RETURN PANEL / PANNEAU DE RETOUR	1
16	DOOR PANEL / PANNEAU DE PORTE	1
17	HINGE (see chart below) / CHARNIÈRE (voir le tableau ci-dessous)	2
18	HANDLE (see chart below) / POIGNÉE (voir le tableau ci-dessous)	1
19	WALL PLUG / CHEVILLE	4
20	PAN SELF-DRILLING SCREW # 8 (1 ¼") / VIS PAN AUTO-PERÇANTE # 8 (1 ¼")	3
21	PAN SELF-DRILLING SCREW # 8 (¾") / VIS PAN AUTO-PERÇANTE # 8 (¾")	3
22	BACK SCREW CAP / L'ARRIÈRE DU CAPUCHON COUVRE-VIS	4
23	SCREW CAP / CAPUCHON COUVRE-VIS	4
24	2" SPACING BLOCK / BLOC ESPACEUR 2"	2
25	CLEAR SETTING BLOCK (¼") / BLOC NIVEAU TRANSPARENT (¼")	4
26	CLEAR SETTING BLOCK (⅜") / BLOC NIVEAU TRANSPARENT (⅜")	4

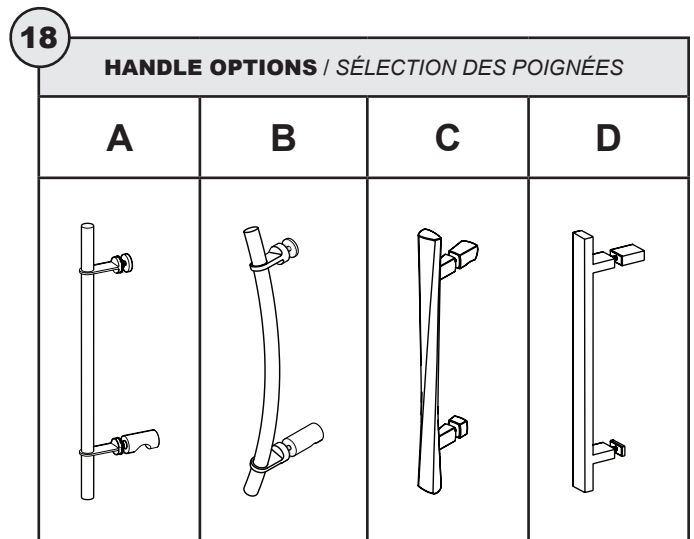
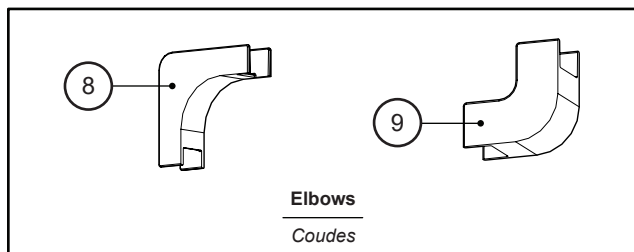
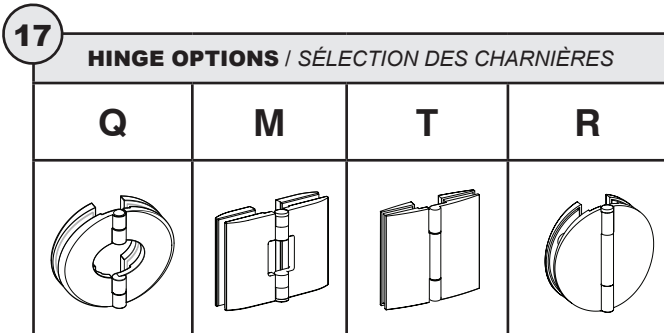

1 MARK THE CENTERLINE ON THE BASE ACCORDING TO THE GIVEN DIMENSIONS
TRACER LA LIGNE CENTRALE SUR LA BASE SELON LES DIMENSIONS INDIQUÉES



THE INSTALLATION SHOWN IS BASED ON PLUMB FINISHED WALLS AND A LEVELLED BASE. IF THESE CONDITIONS ARE NOT MET, PLEASE ADJUST ACCORDINGLY.

L'INSTALLATION ILLUSTRÉE EST BASÉE SUR DES MURS FINIS D'APLOMB ET UNE BASE DE DOUCHE NIVELÉE. SI CES CONDITIONS NE SONT PAS PRÉSENTÉES, VEUILLEZ AJUSTER EN CONSÉQUENCE.

TOP VIEW
VUE DU HAUT

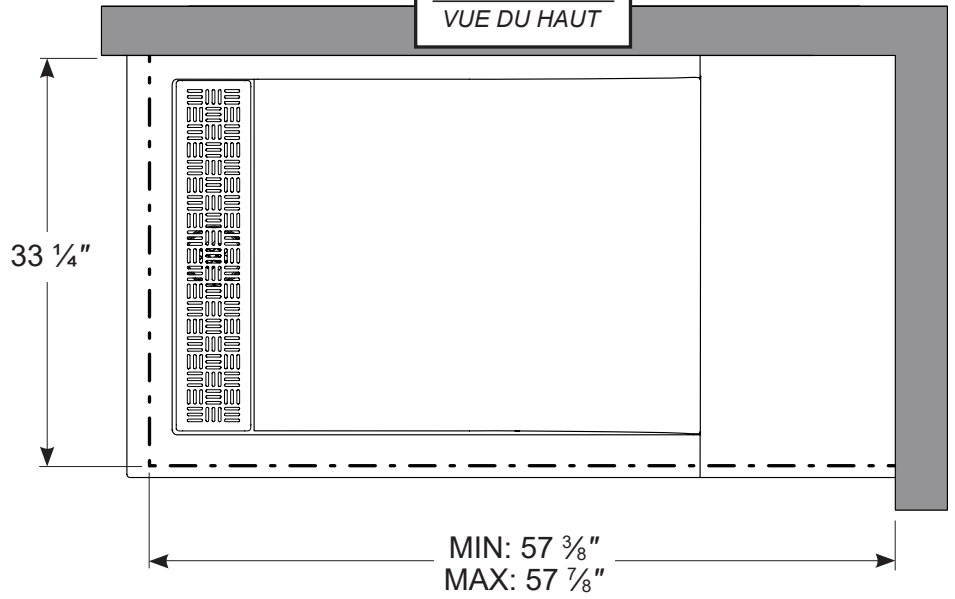

ENSURE THE CENTER LINE FOR THE HINGE INSTALLATION IS PLACED ON A WALL STUD.

S'ASSURER QUE LA LIGNE CENTRALE POUR L'INSTALLATION DES CHARNIÈRES EST PLACÉE SUR UN MONTANT MURAL.

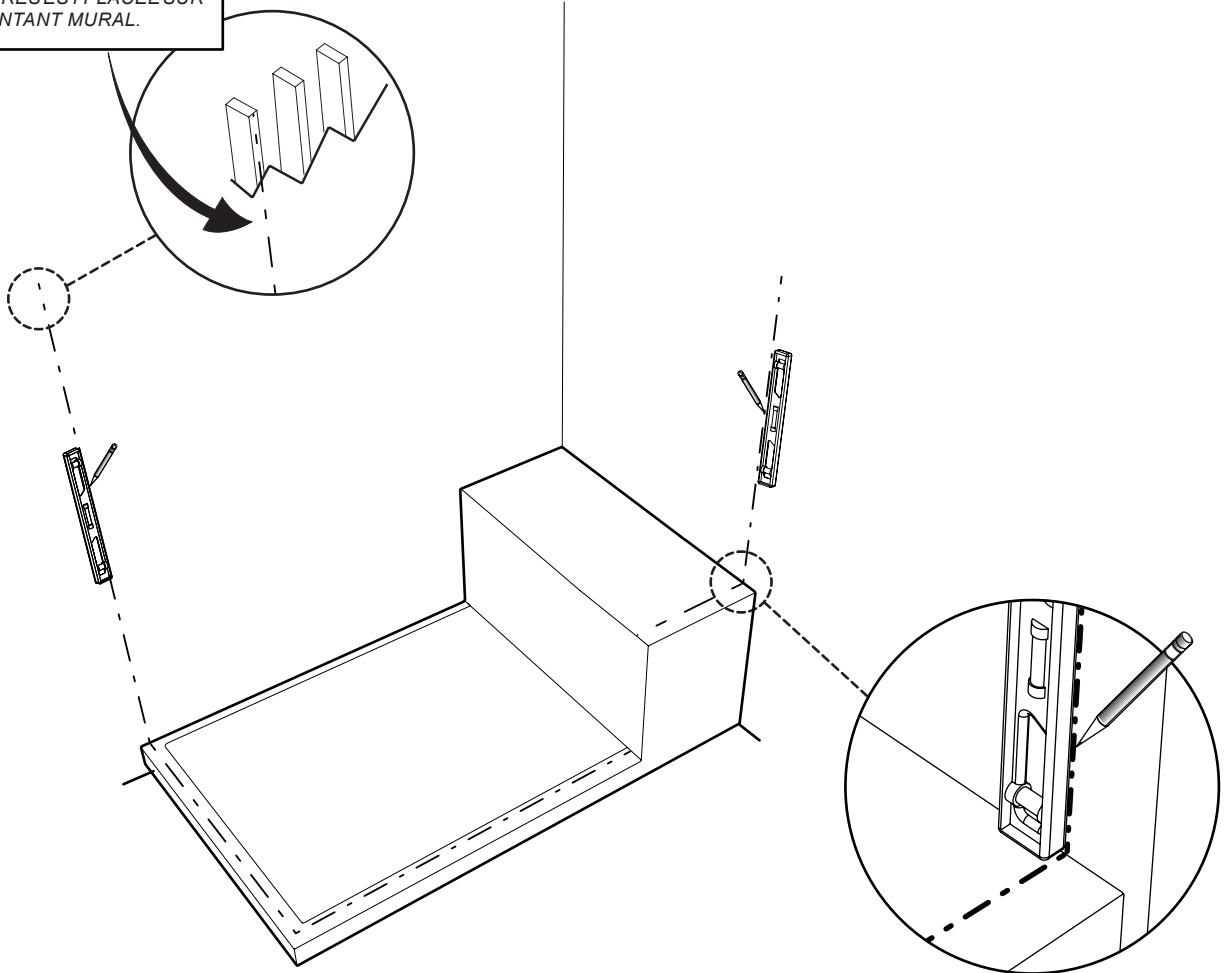

2

MARK THE HINGE LOCATIONS AND WALL JAMB HOLE POSITIONS

MARQUER L'EMPLACEMENT DES CHARNIÈRES ET LES POSITIONS DES TROUS DU JAMBAGE

Hinge Location Localisation des charnières	
A	5 5/8"
B	7 3/8"
C	72 3/16"
D	73 15/16"

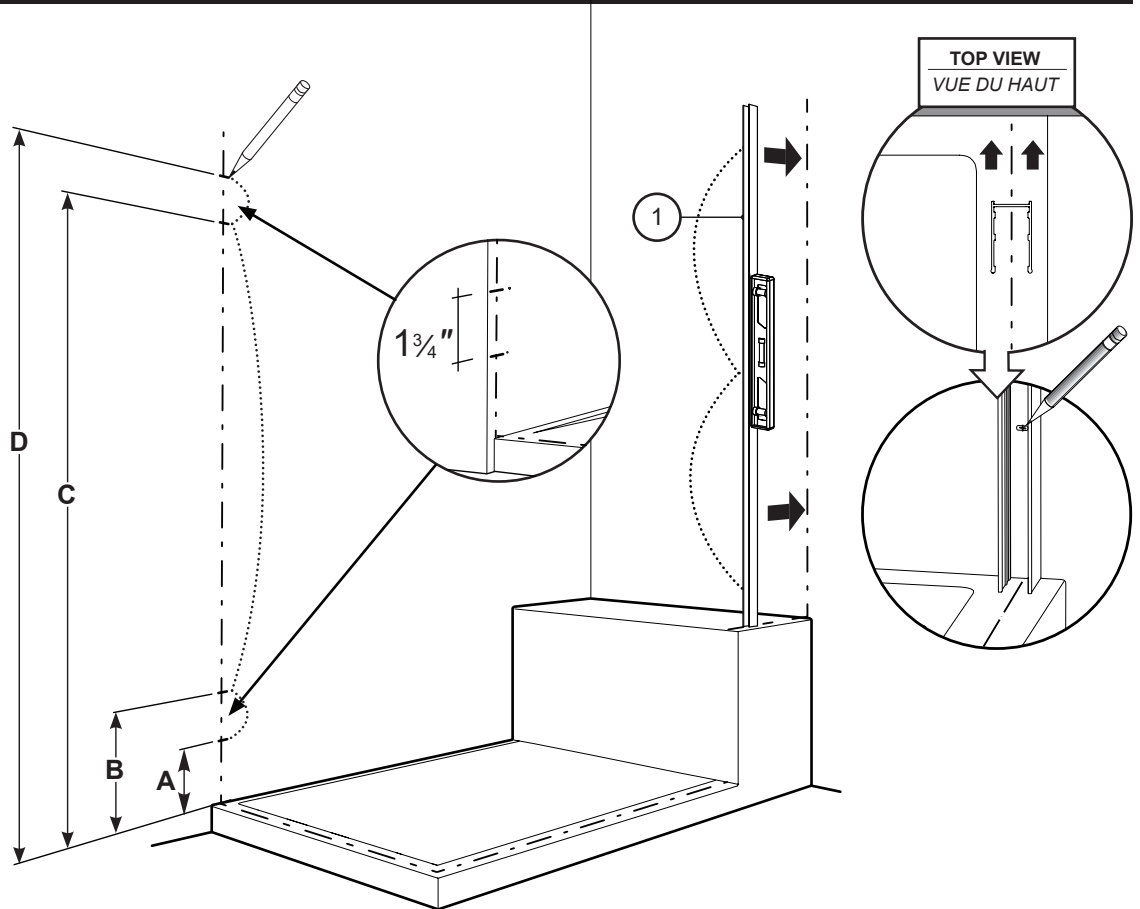

3

MARK THE LOCATION OF THE HINGES (CONT'D) / MARQUER L'EMPLACEMENT DES CHARNIÈRES (SUITE)

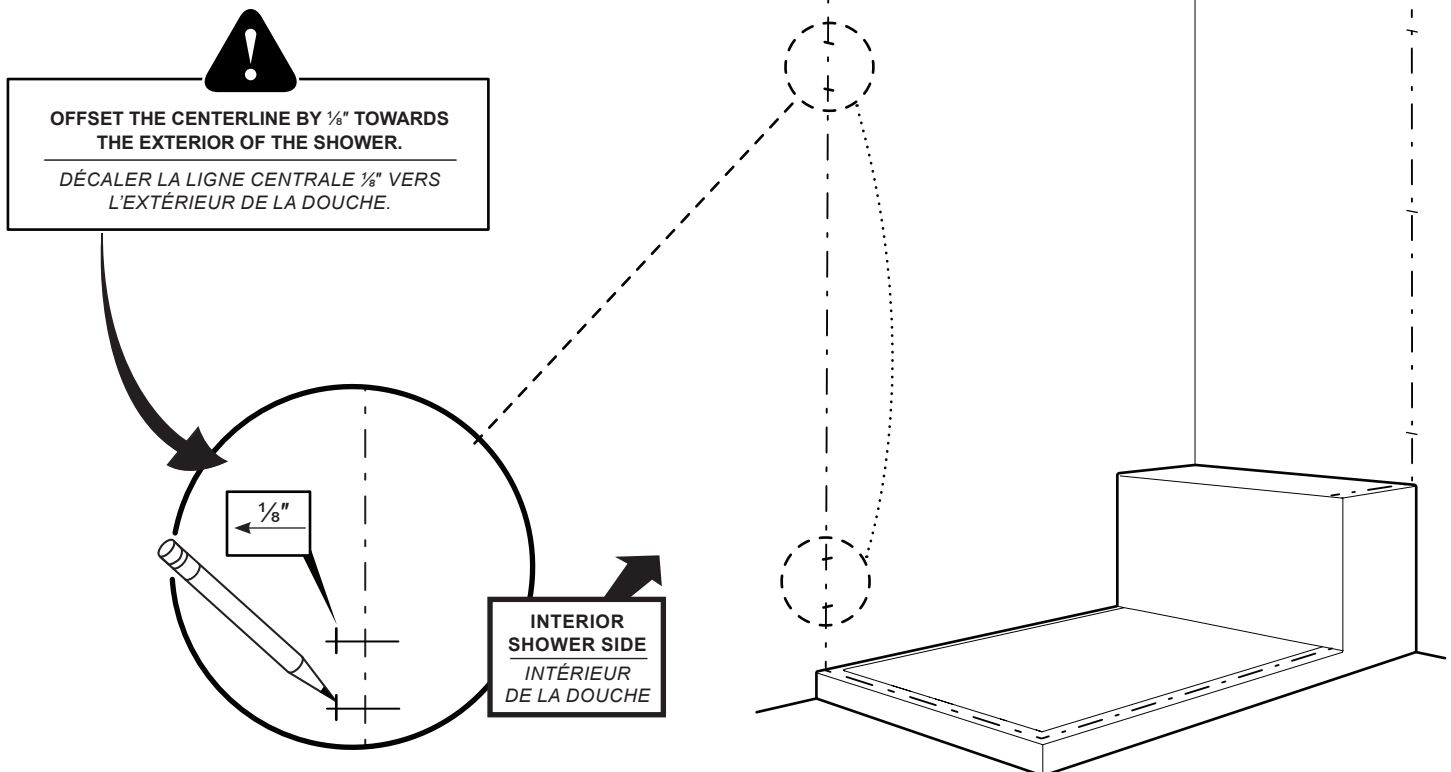

4

INSTALL THE WALL PLUGS / INSTALLER LES CHEVILLES

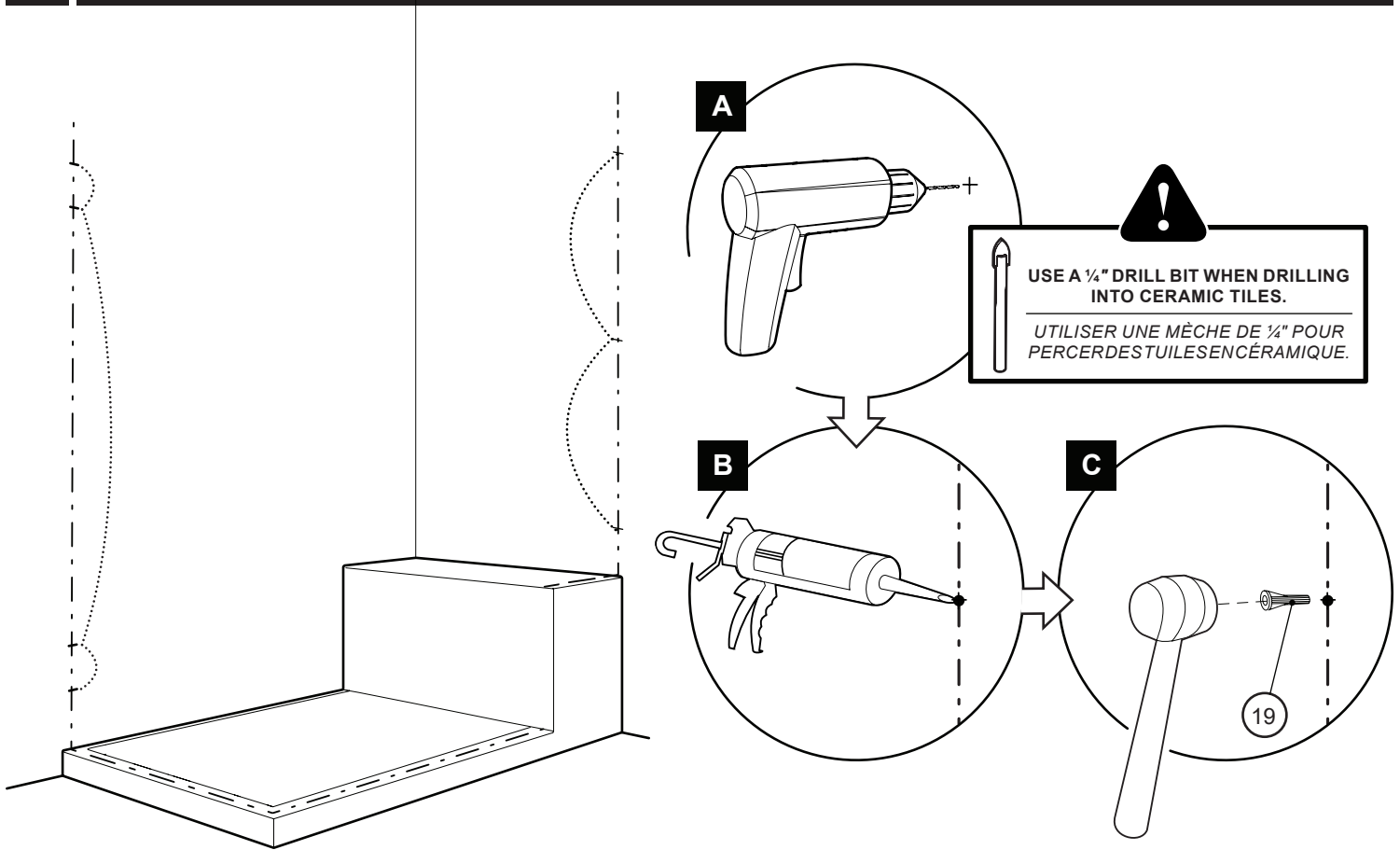

5

INSTALL THE WALL JAMB AND THE HINGES / INSTALLER LE JAMBAGE ET LES CHARNIÈRES

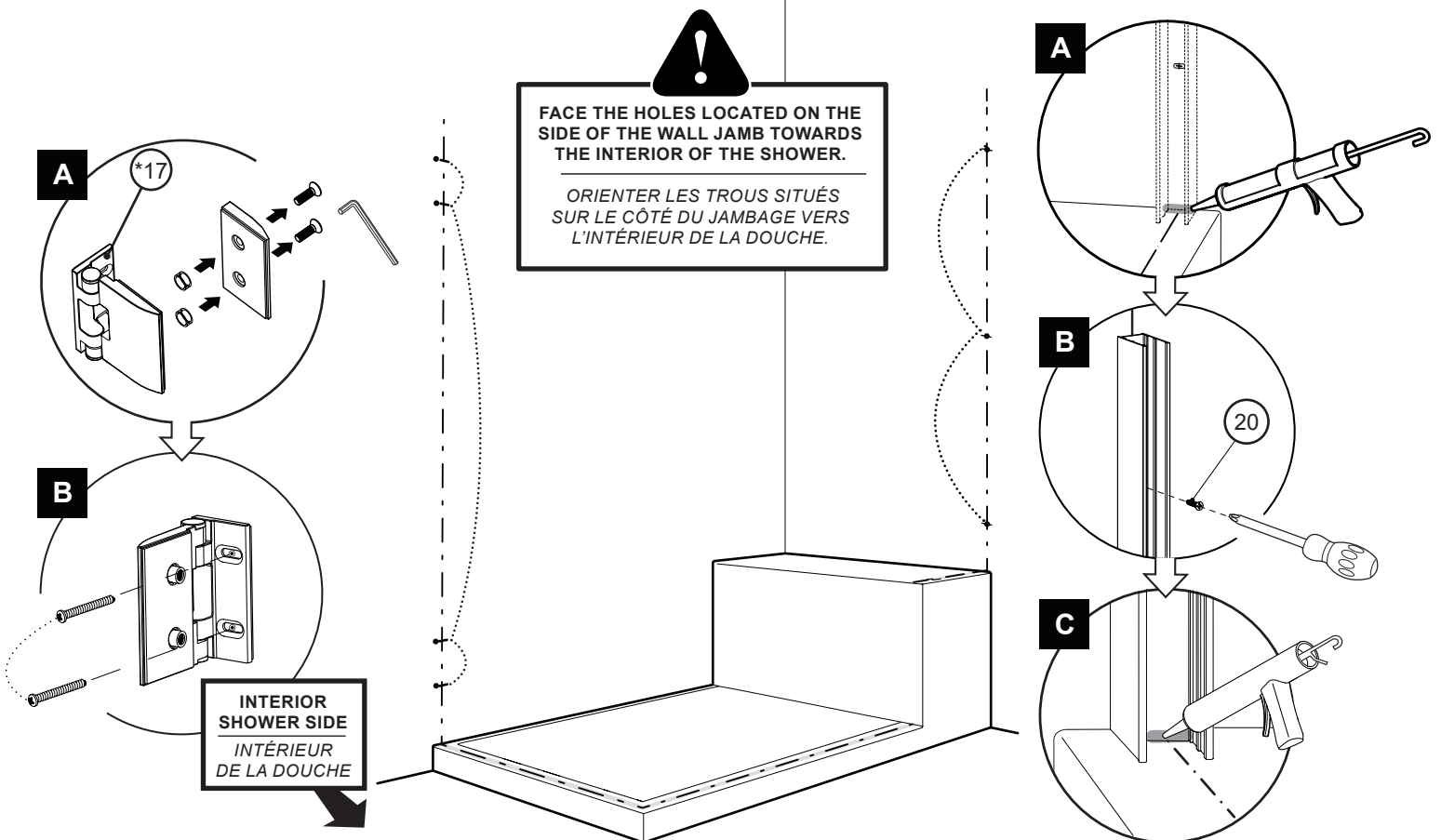

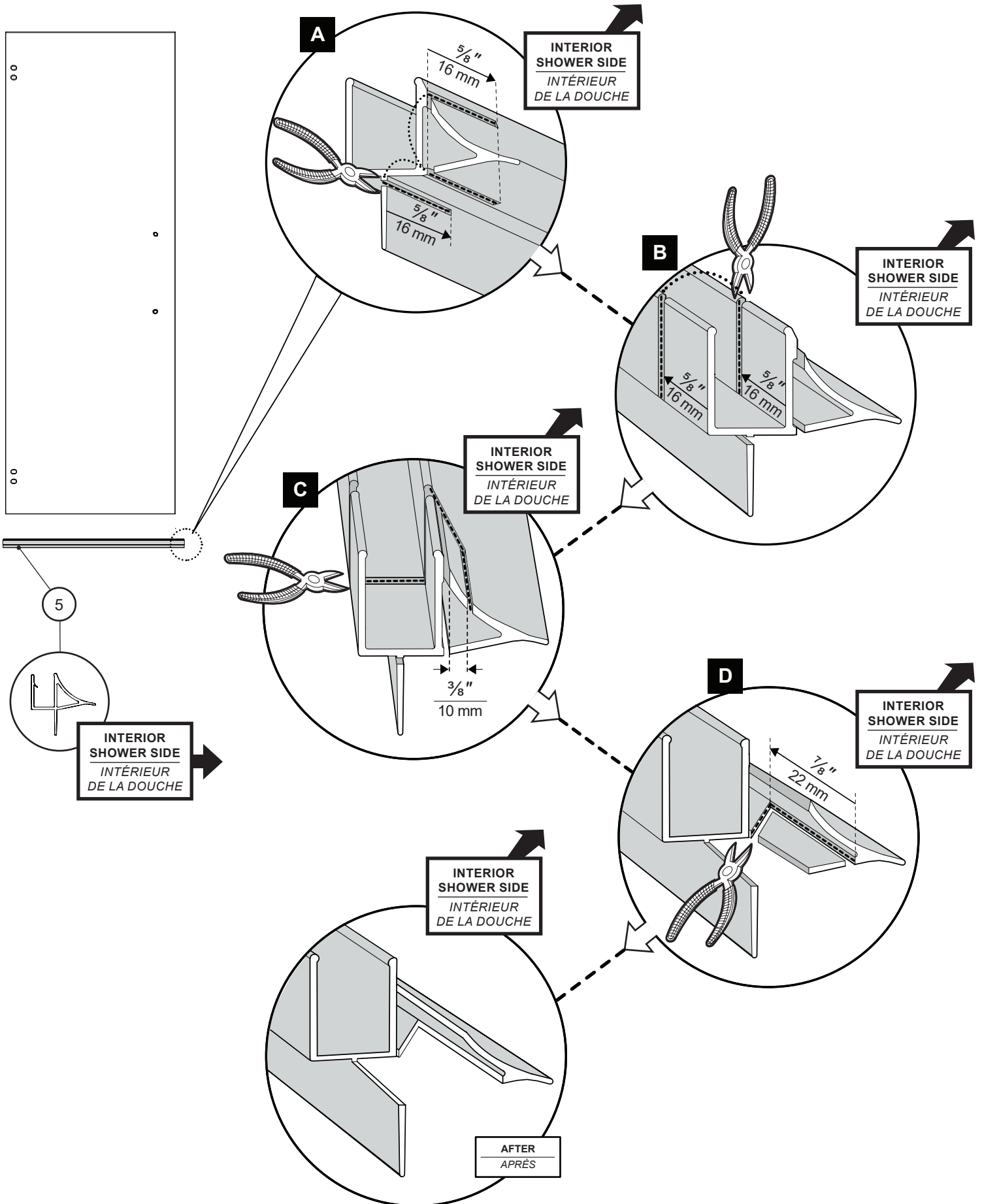

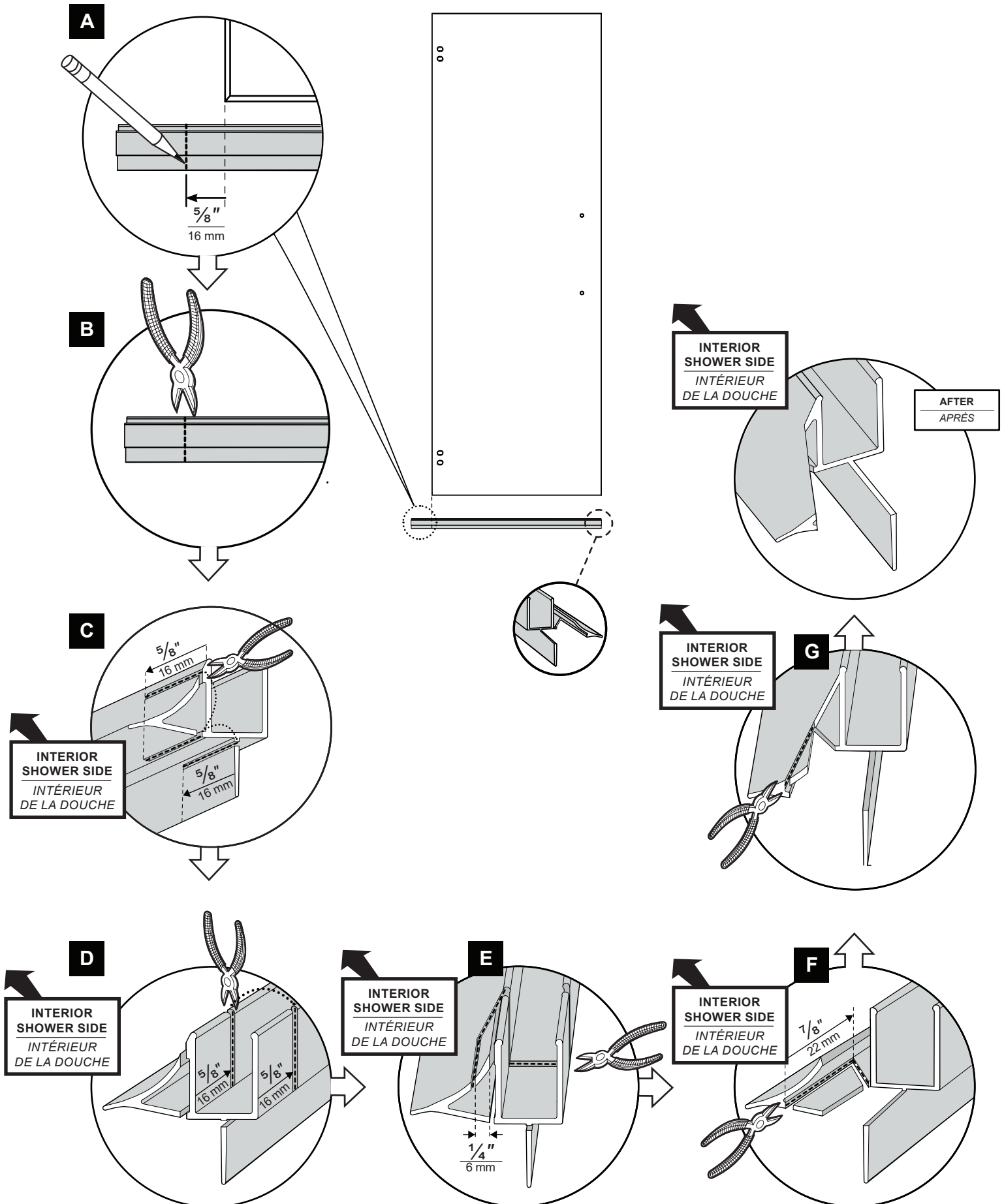

8 **INSTALL THE BOTTOM DOOR GASKET AND SPACING BLOCKS**
INSTALLER LE JOINT INFÉRIEUR DE LA PORTE ET LES BLOCS ESPACEURS

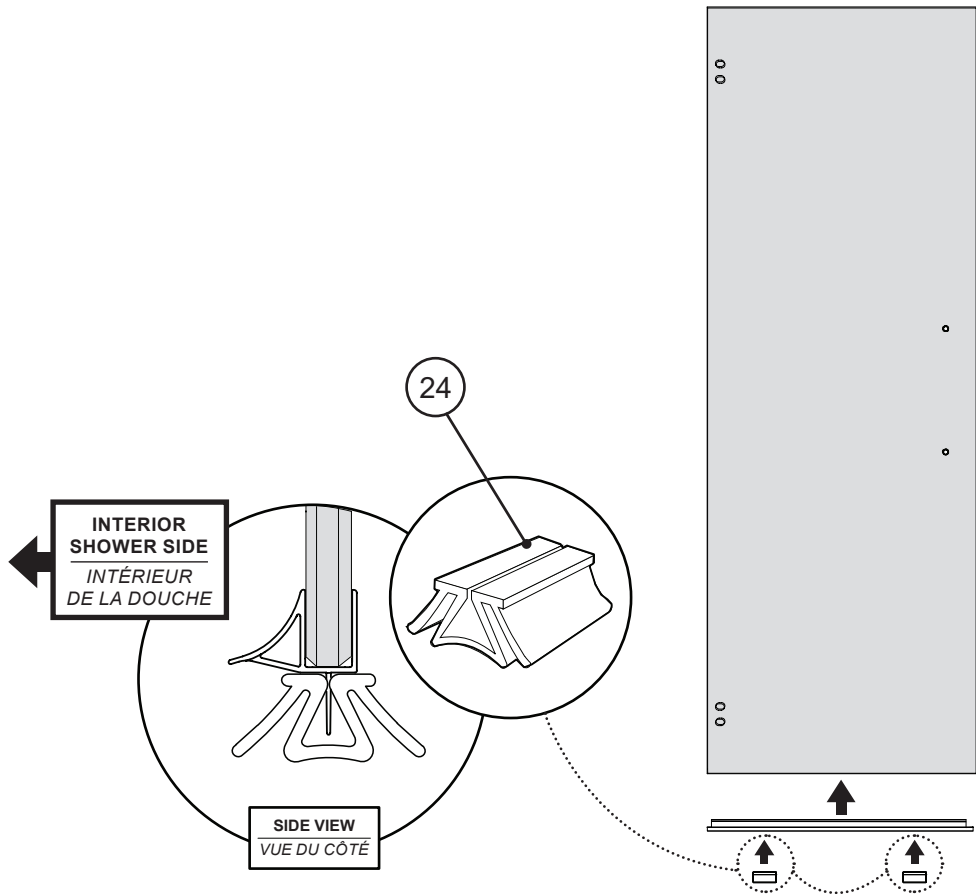

9 **INSTALL THE DOOR / INSTALLER LA PORTE**

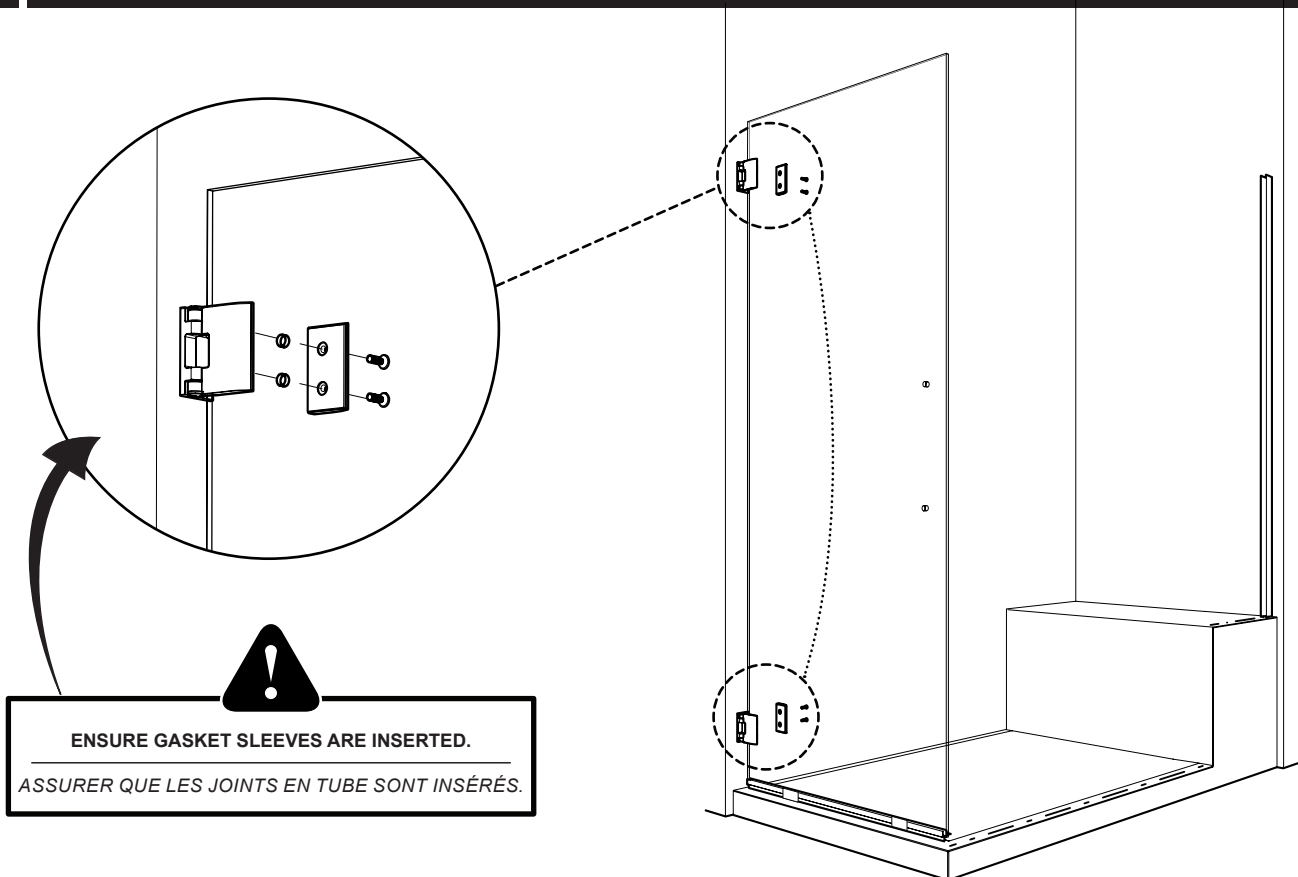

10

INSTALL THE SIDE DOOR GASKET / INSTALLER LE JOINT LATÉRAL DE LA PORTE

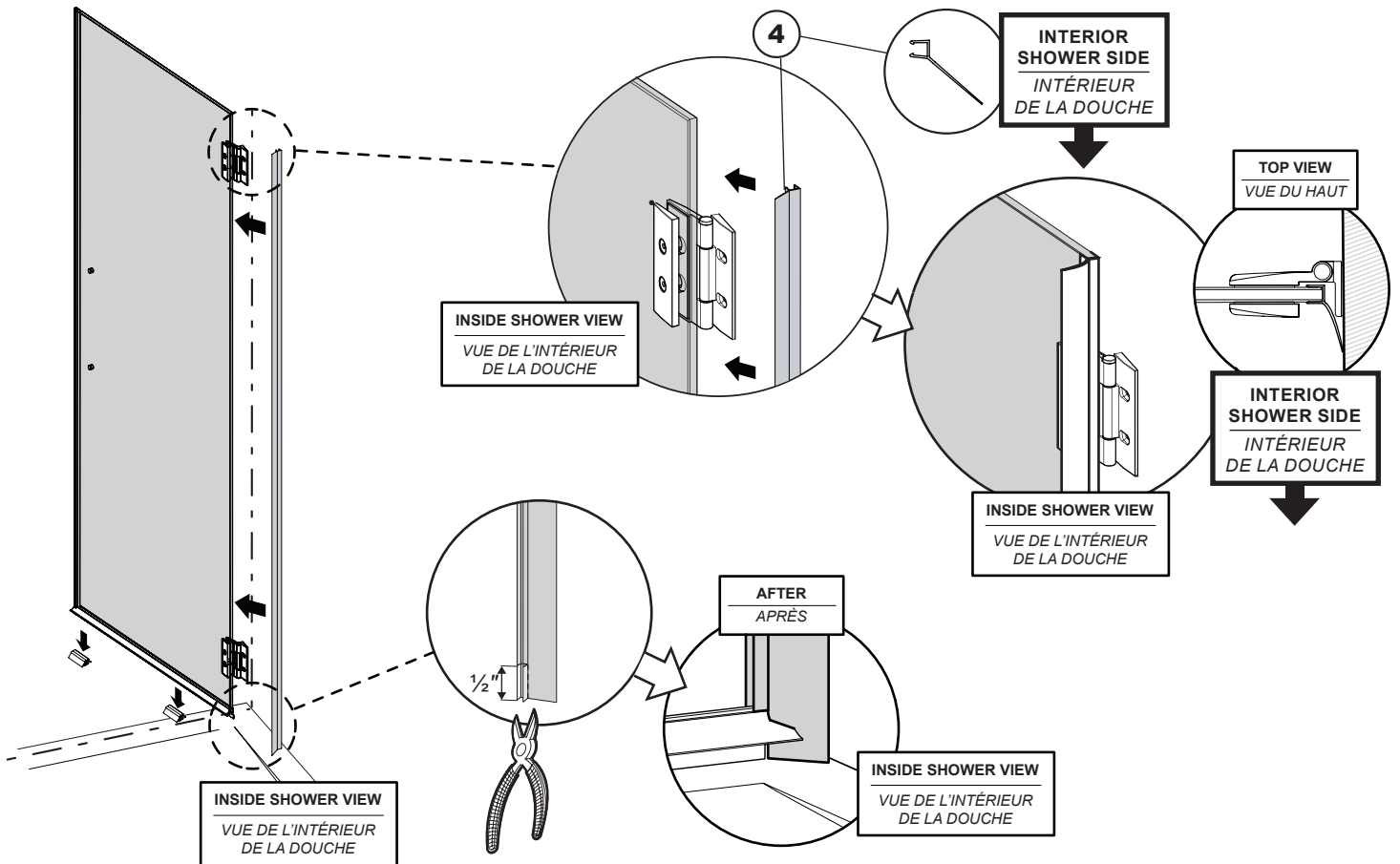

11

INSTALL THE MAGNETIC DOOR GASKET AND THE HANDLE
INSTALLER LE JOINT MAGNÉTIQUE DE LA PORTE ET LA POIGNÉE

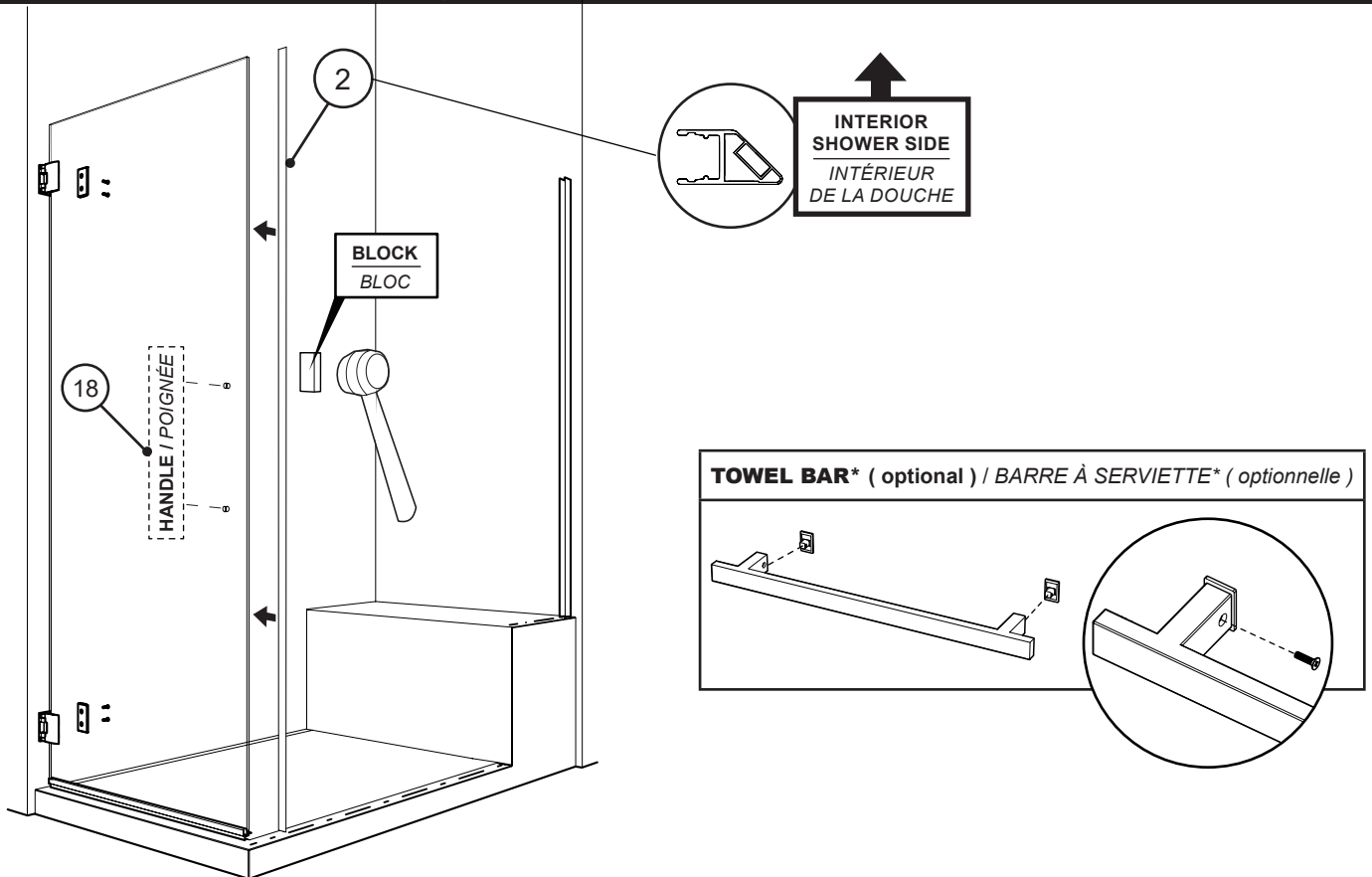

12 INSTALL THE TOP AND BOTTOM ELBOW / INSTALLER LE COUDE INFÉRIEUR ET SUPÉRIEUR

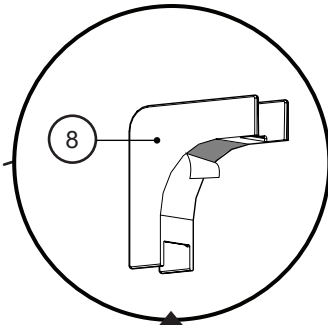
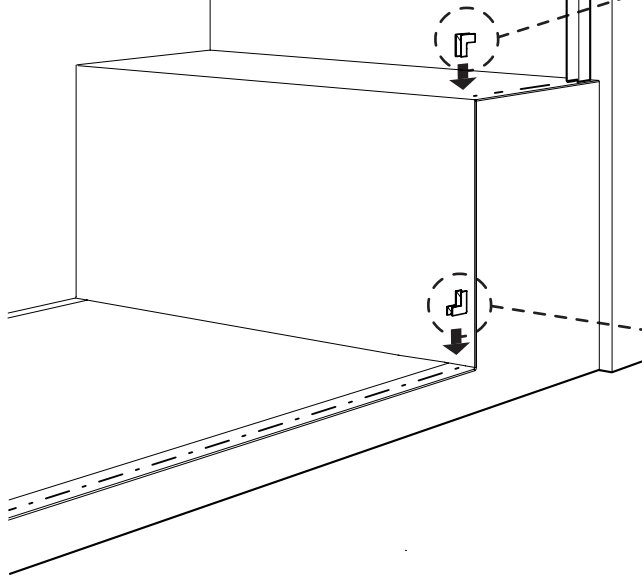
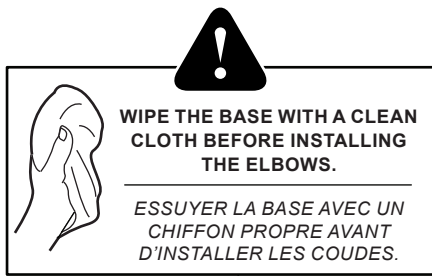

ALIGN THE CENTER OF THE ELBOWS TO THE CENTERLINE.

ALIGNER LE CENTRE DES COUDES AVEC LA LIGNE DU CENTRE.

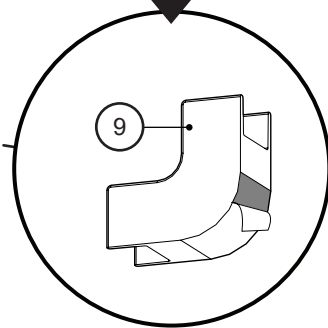

13 INSTALL THE U-CHANNELS / INSTALLER LES PROFILÉ EN «U»

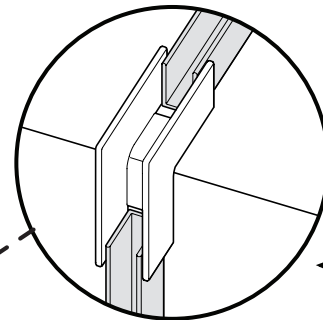
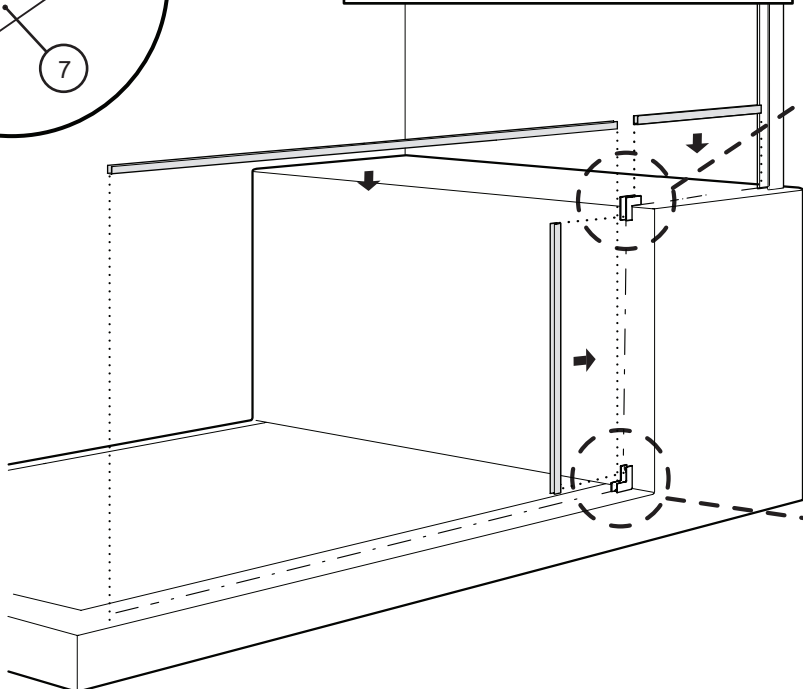
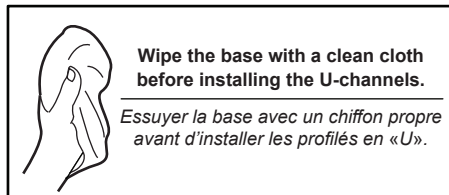
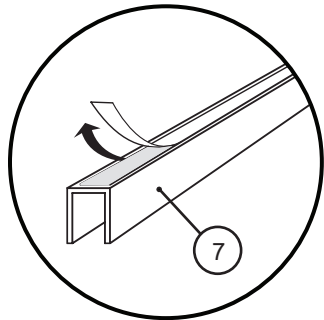

Push the U-channels into the elbows.

Pousser les profilés en «U» au fond des coudes.

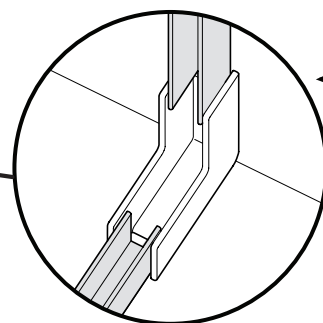

14

INSTALL THE RETURN PANEL / INSTALLER LE PANNEAU DE RETOUR

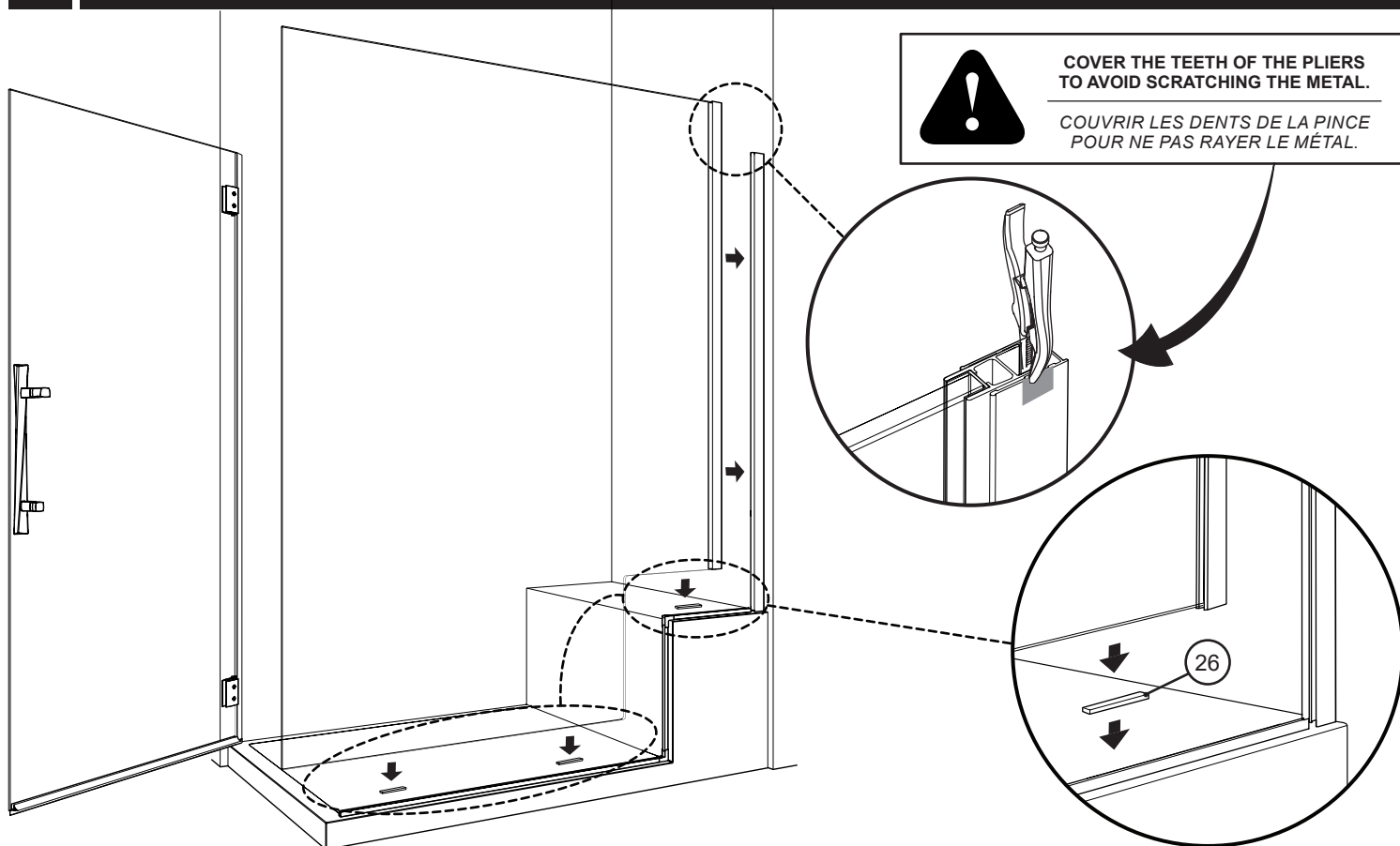

15

INSTALL THE CORNER THRESHOLD ANCHOR AND THE MAGNETIC GASKET
INSTALLER L'ANCRAGE DU SEUIL DE COIN ET LE JOINT MAGNÉTIQUE

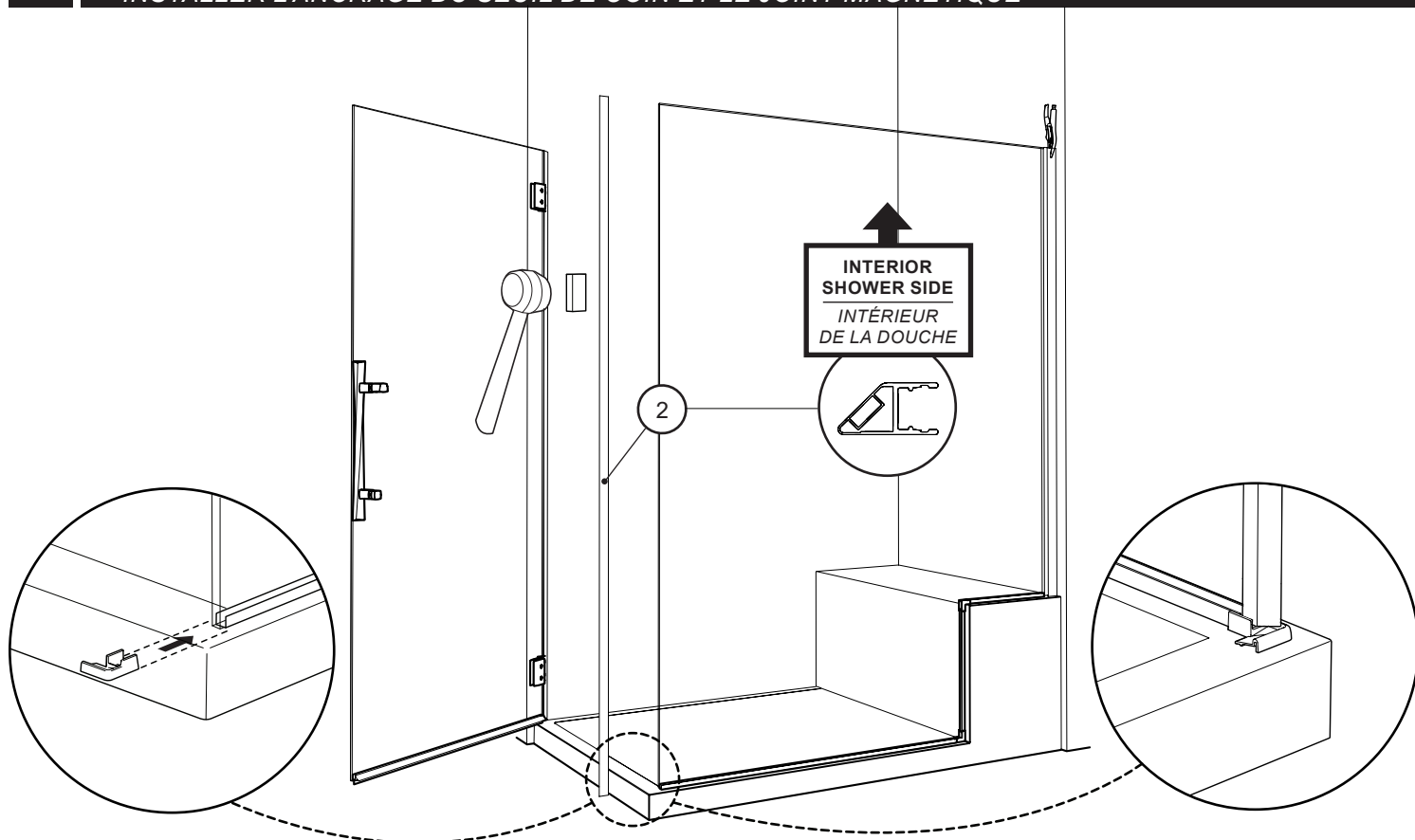

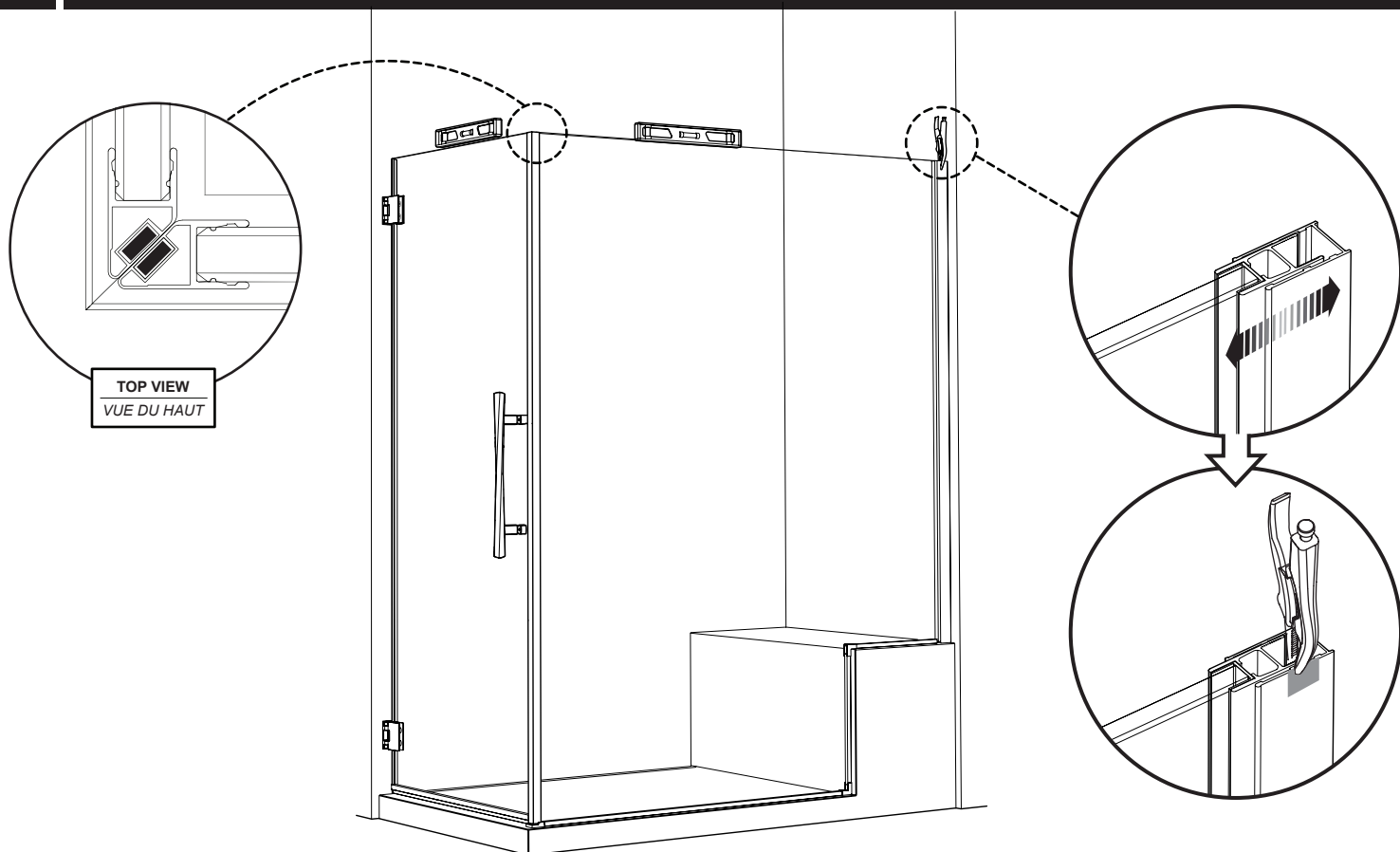
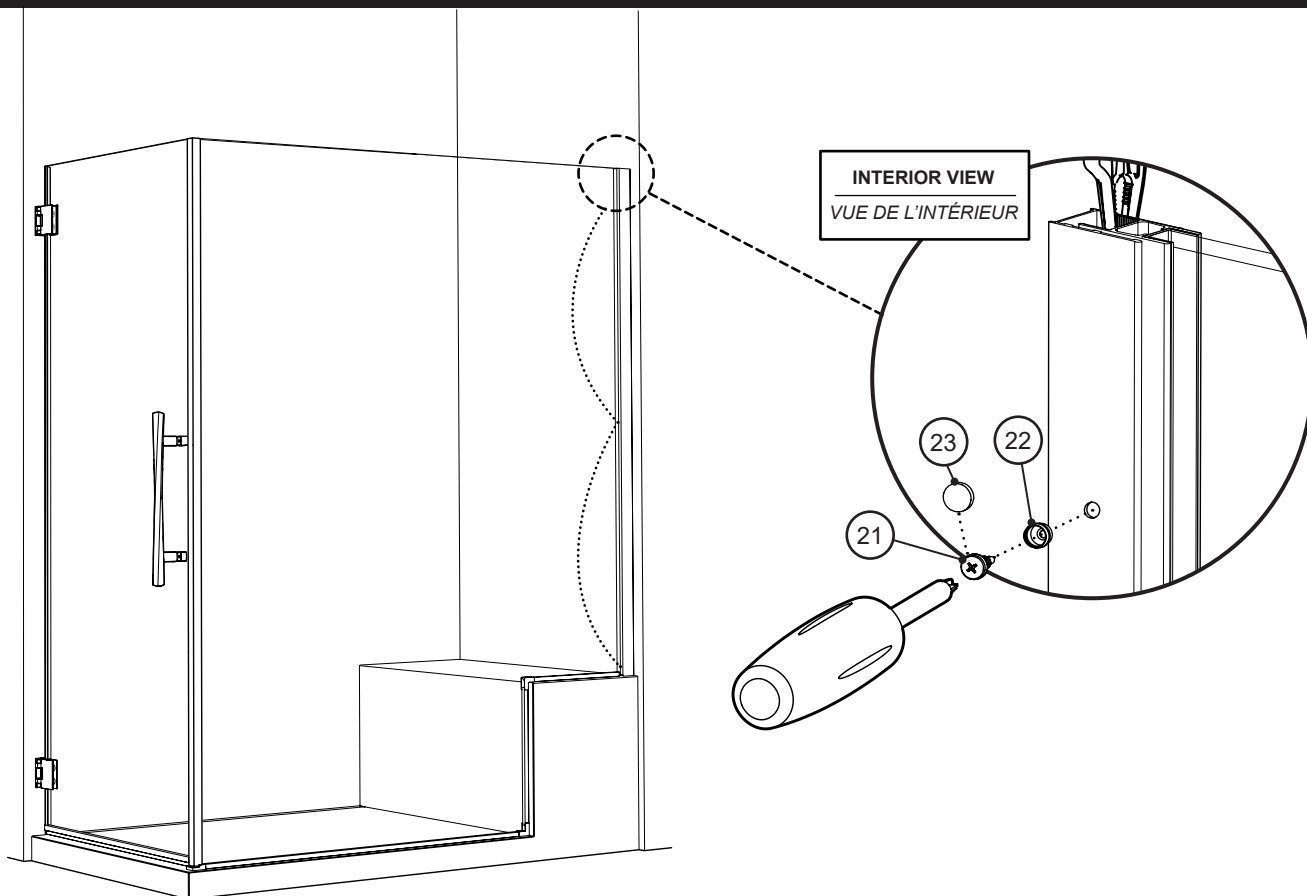
16**LEVEL AND ADJUST THE PANELS / NIVELER ET AJUSTER LES PANNEAUX****17****SECURE THE EXPANDER / SÉCURISER L'EXTENSEUR**

18

ASSEMBLE THE SUPPORT BAR / ASSEMBLER LA BARRE DE SUPPORT

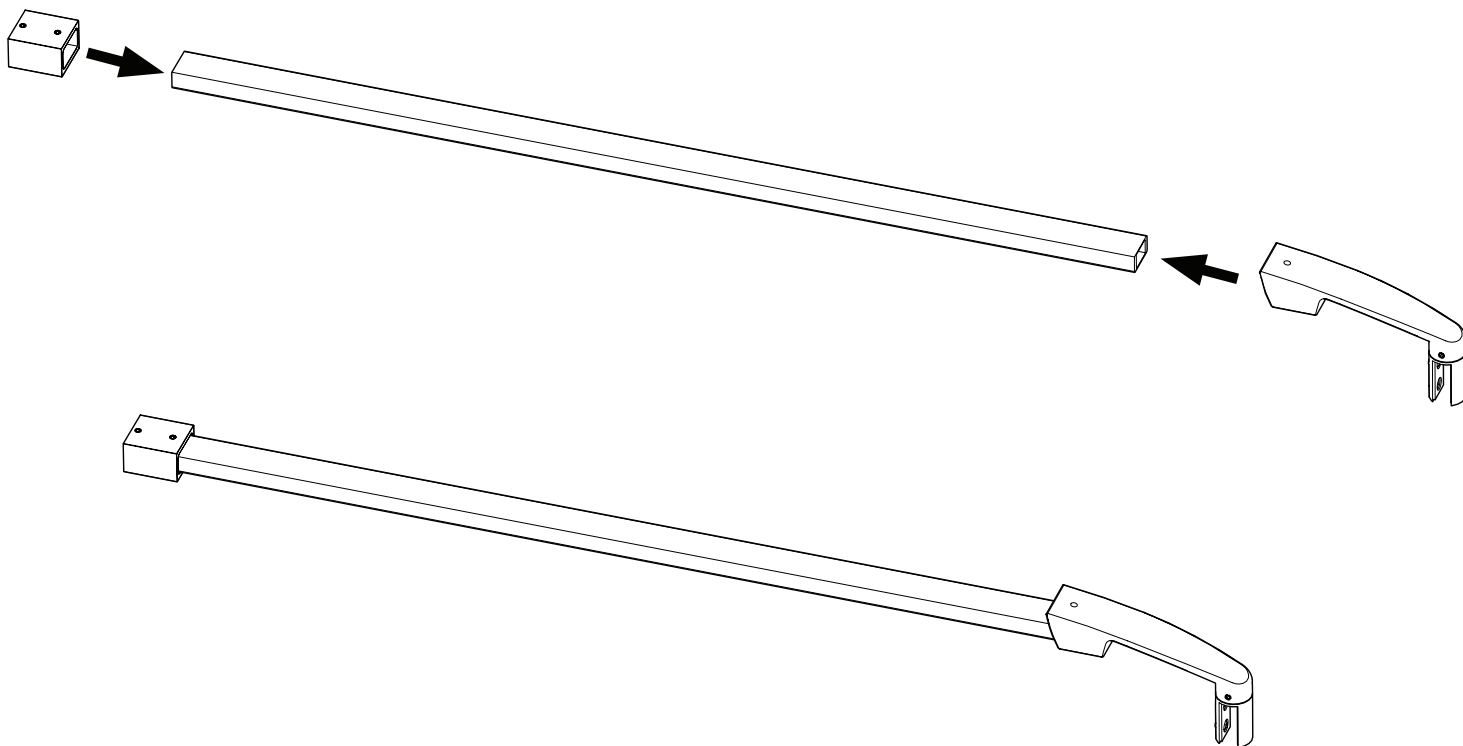

19

PLACE THE SUPPORT BAR ONTO THE UNIT / PLACER LA BARRE DE SUPPORT SUR LA DOUCHE

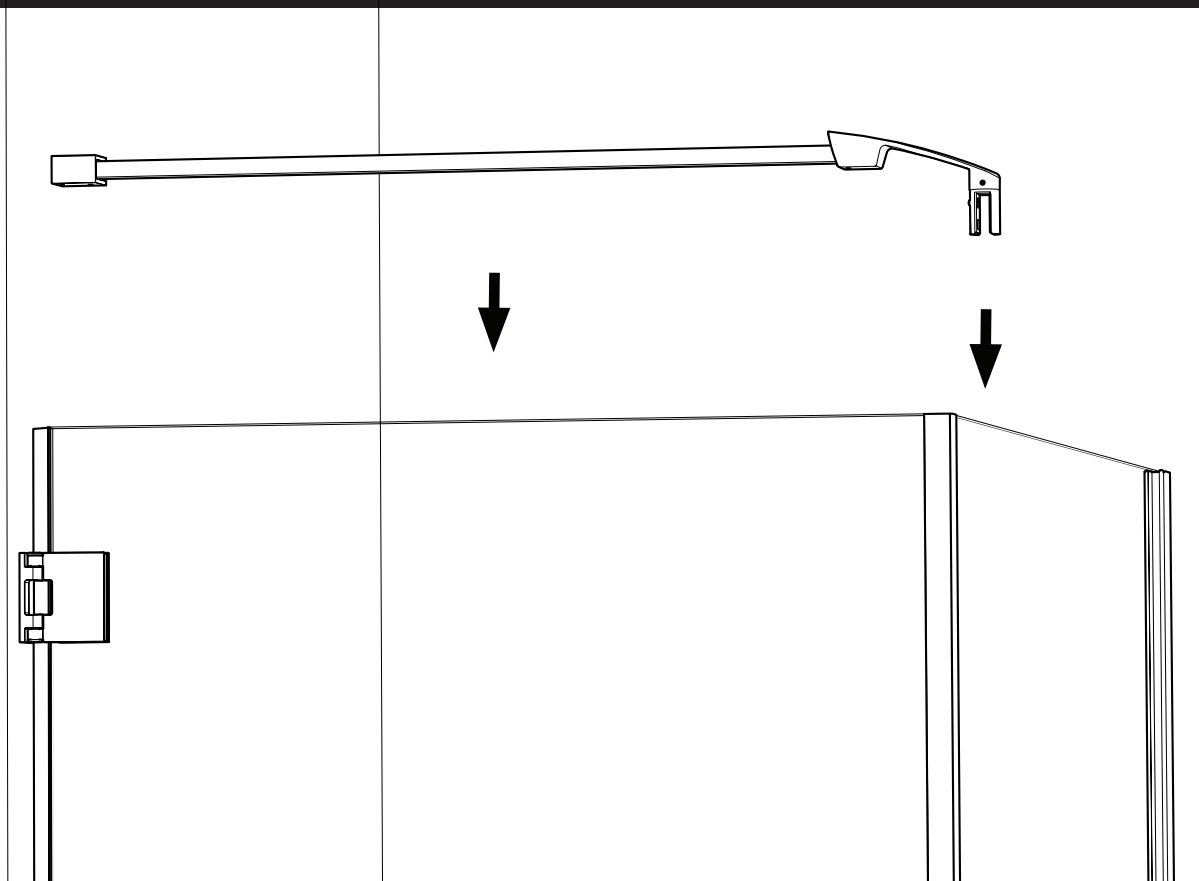

20 LEVEL THE SUPPORT BAR AND MARK THE WALL BRACKET LOCATION
NIVELER LA BARRE DE SUPPORT ET MARQUER L'EMPLACEMENT DU SUPPORT MURALE

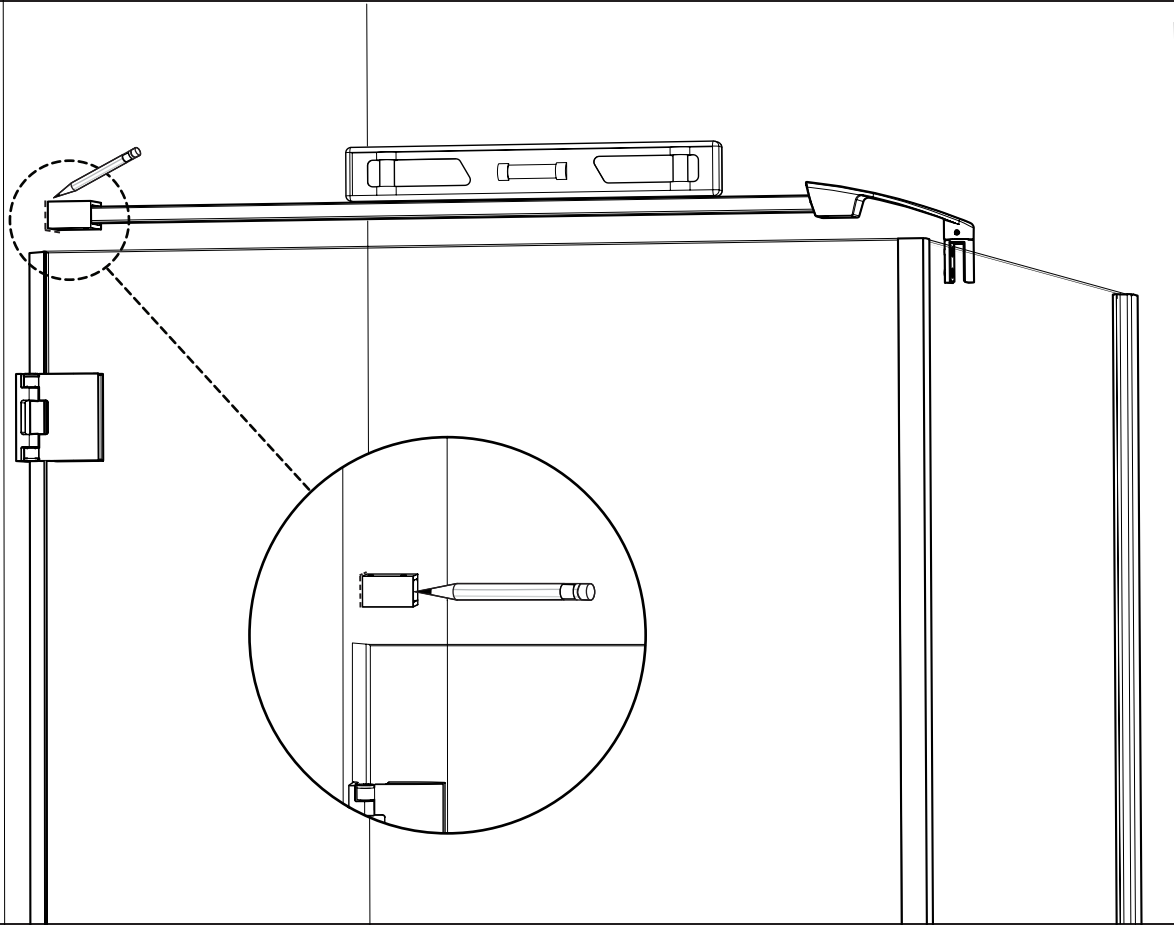

21 INSTALL THE WALL PLUGS / *INSTALLER LES CHEVILLES*

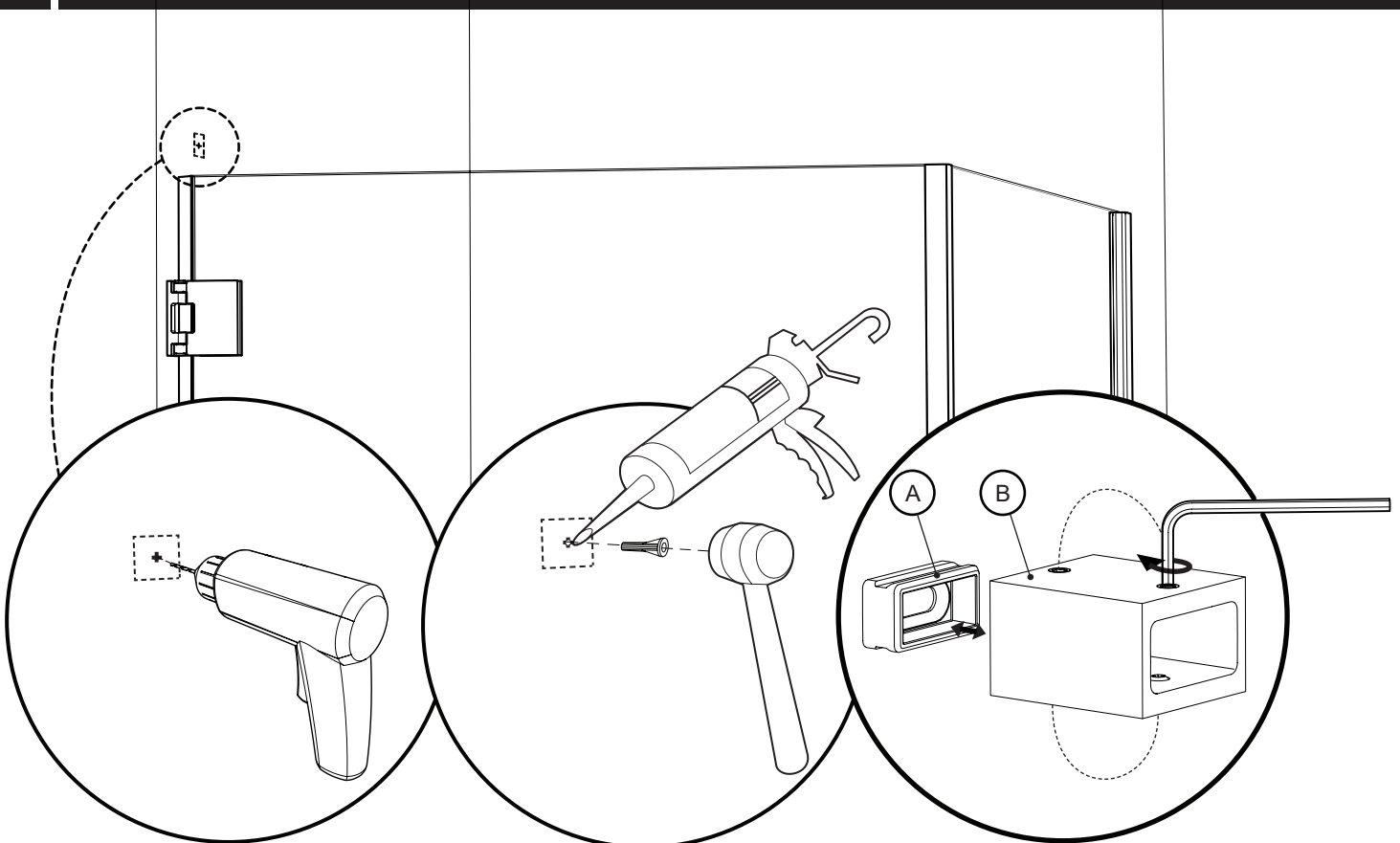

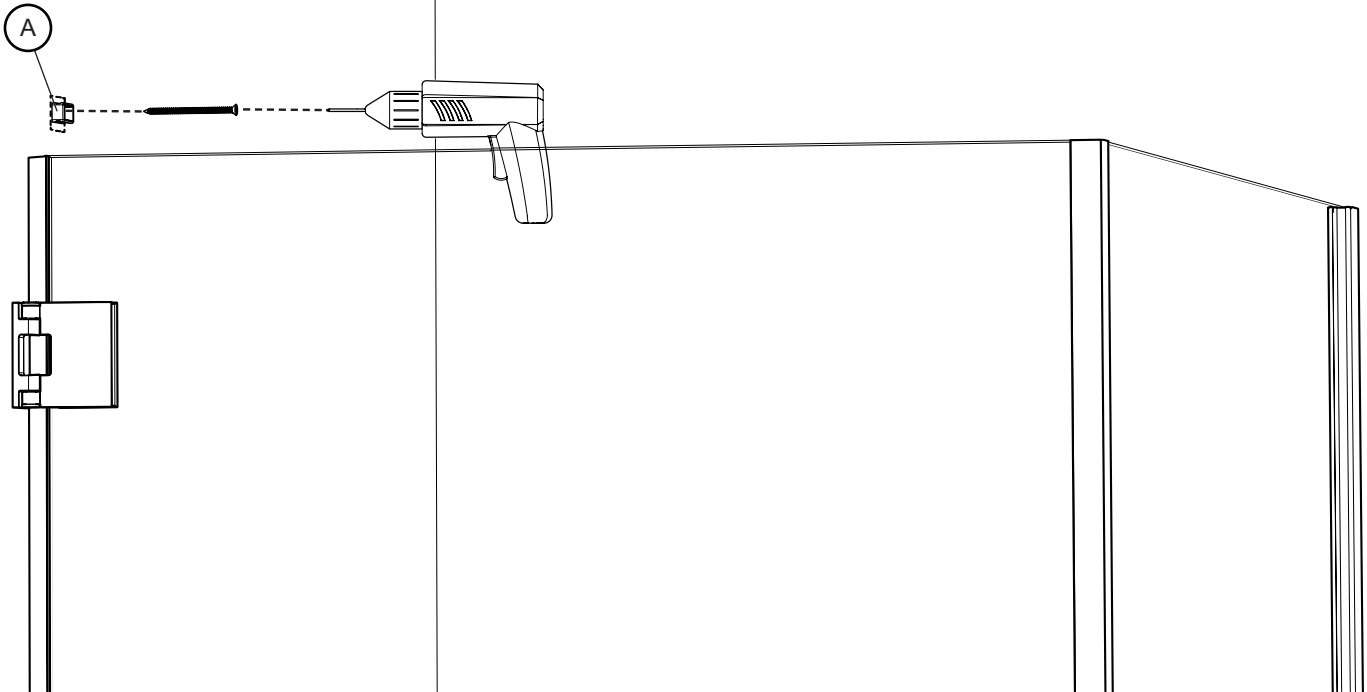
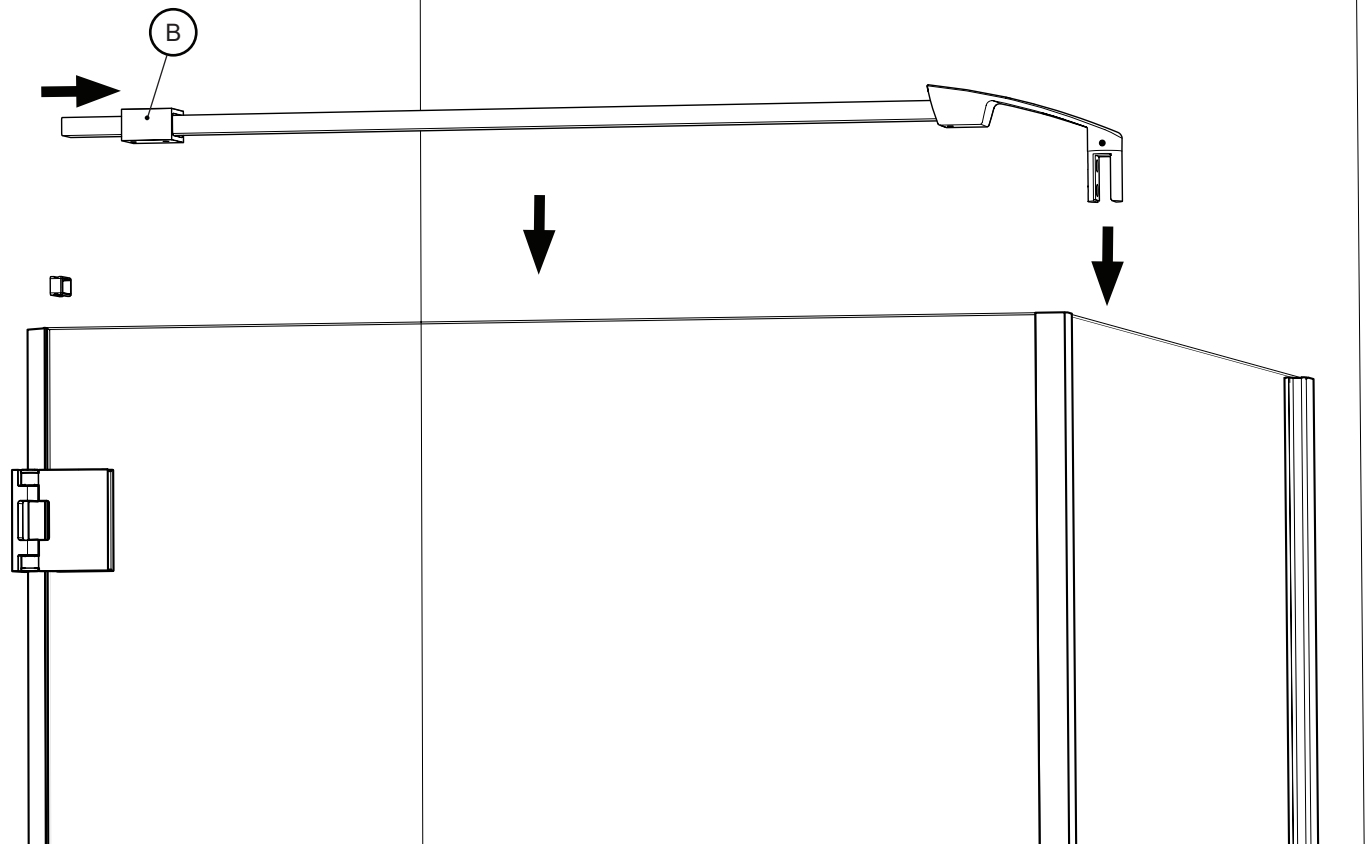
22**SECURE THE WALL BRACKET PLATE / SÉCURISER LA PLAQUE ARRIÈRE DU SUPPORT MURALE****23****INSTALL THE SUPPORT BAR / INSTALLER LA BARRE DE SUPPORT**

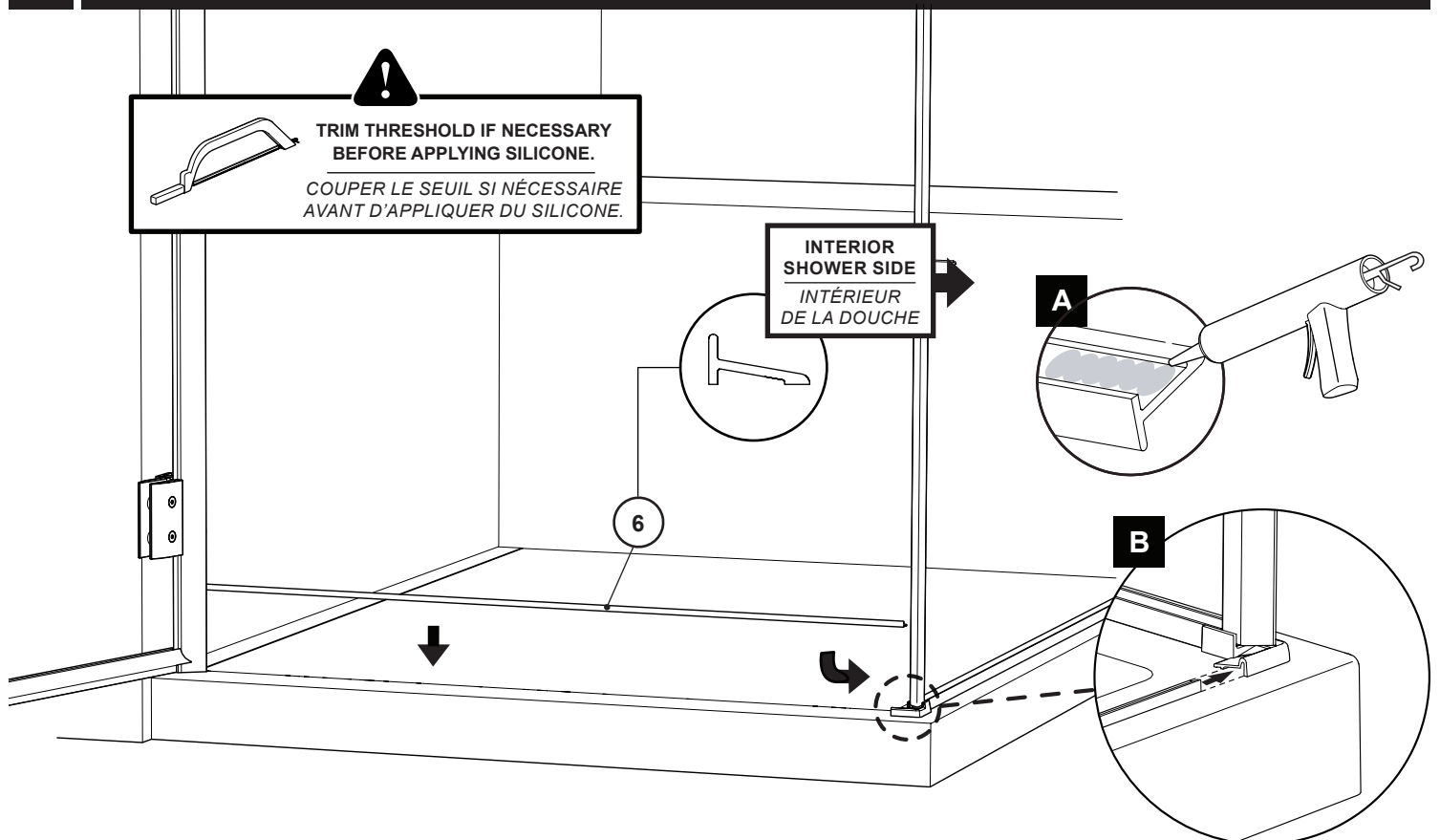
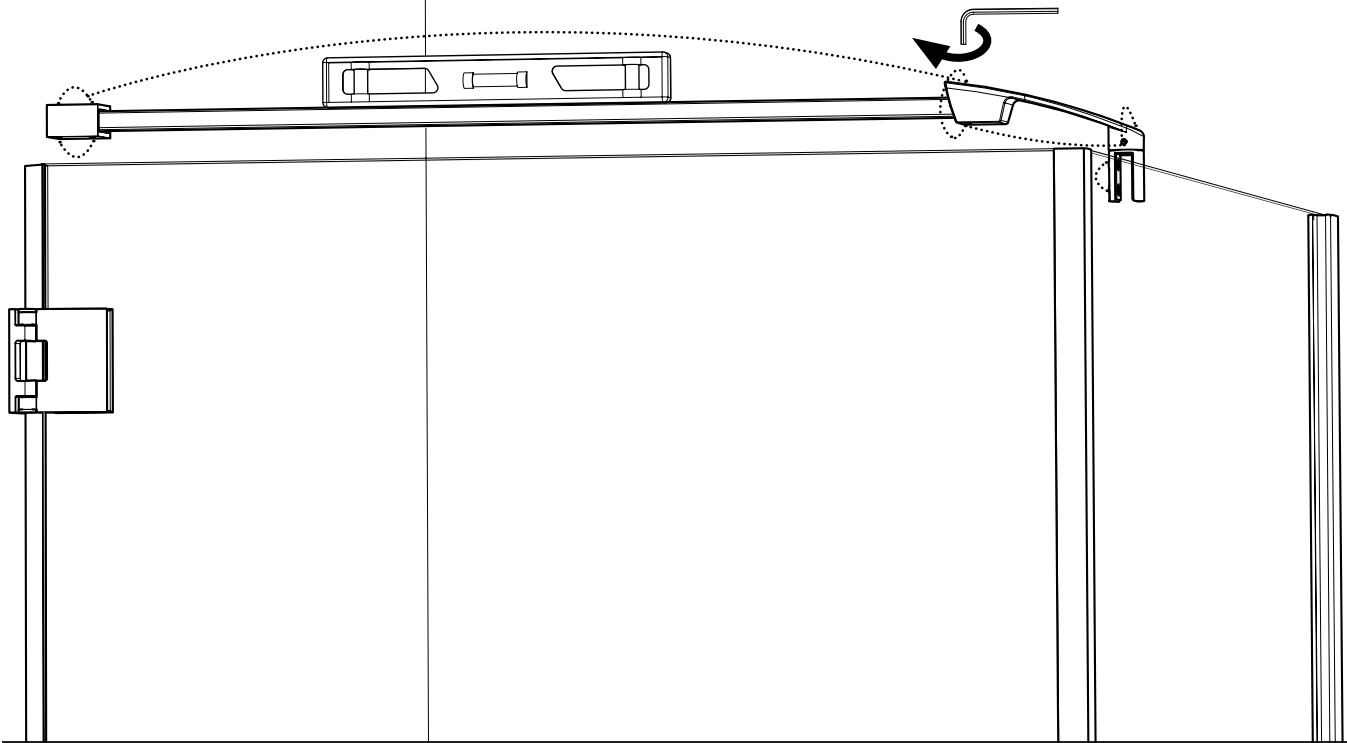

26 INSTALL THE THRESHOLD ANCHOR END / INSTALLER L'ANCRAGE LATÉRAL DU SEUIL

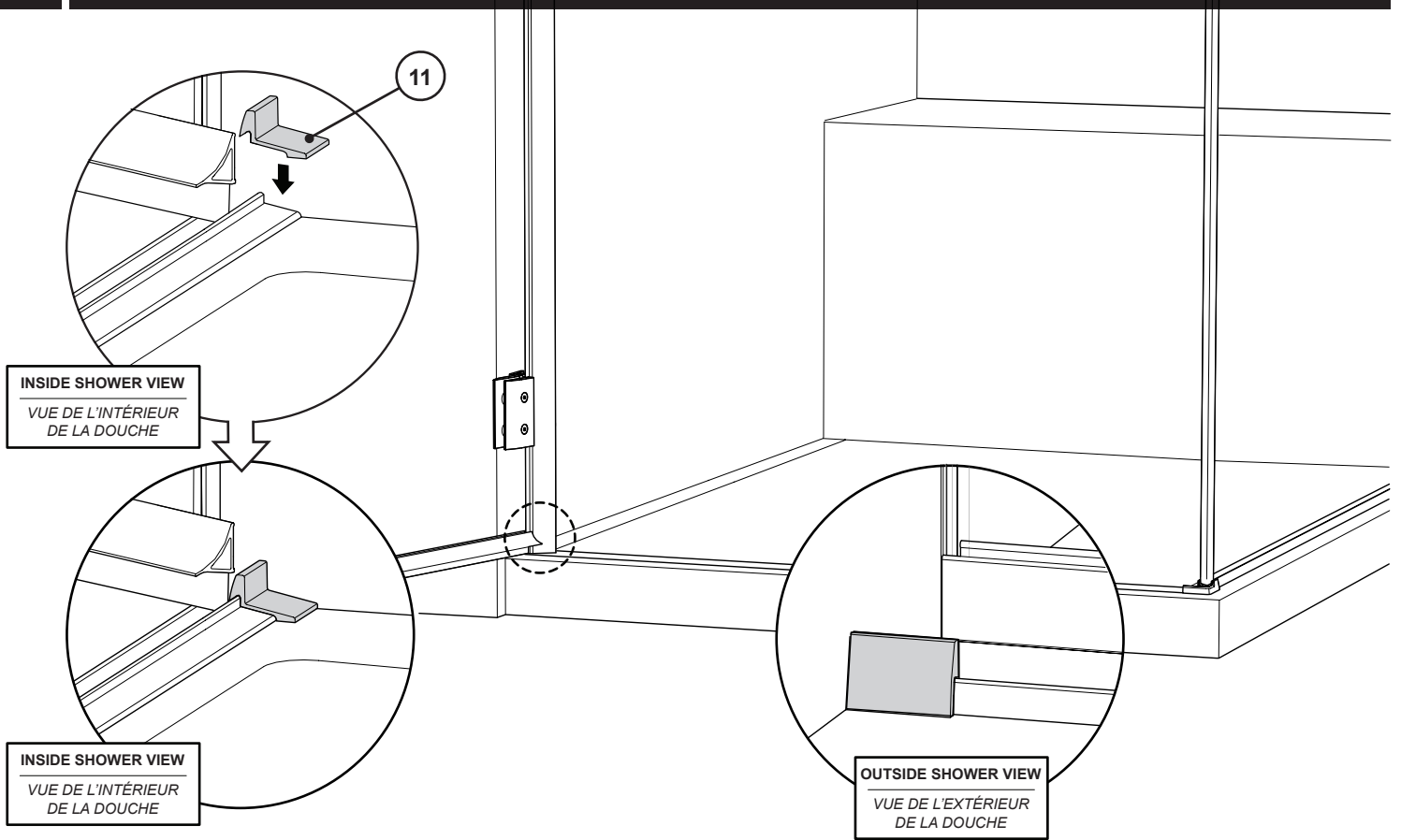

27 SEAL THE SHOWER UNIT / CALFEUTRER LA DOUCHE

