

INSTRUCTION MANUAL - *GUIDE D'INSTALLATION*

P209

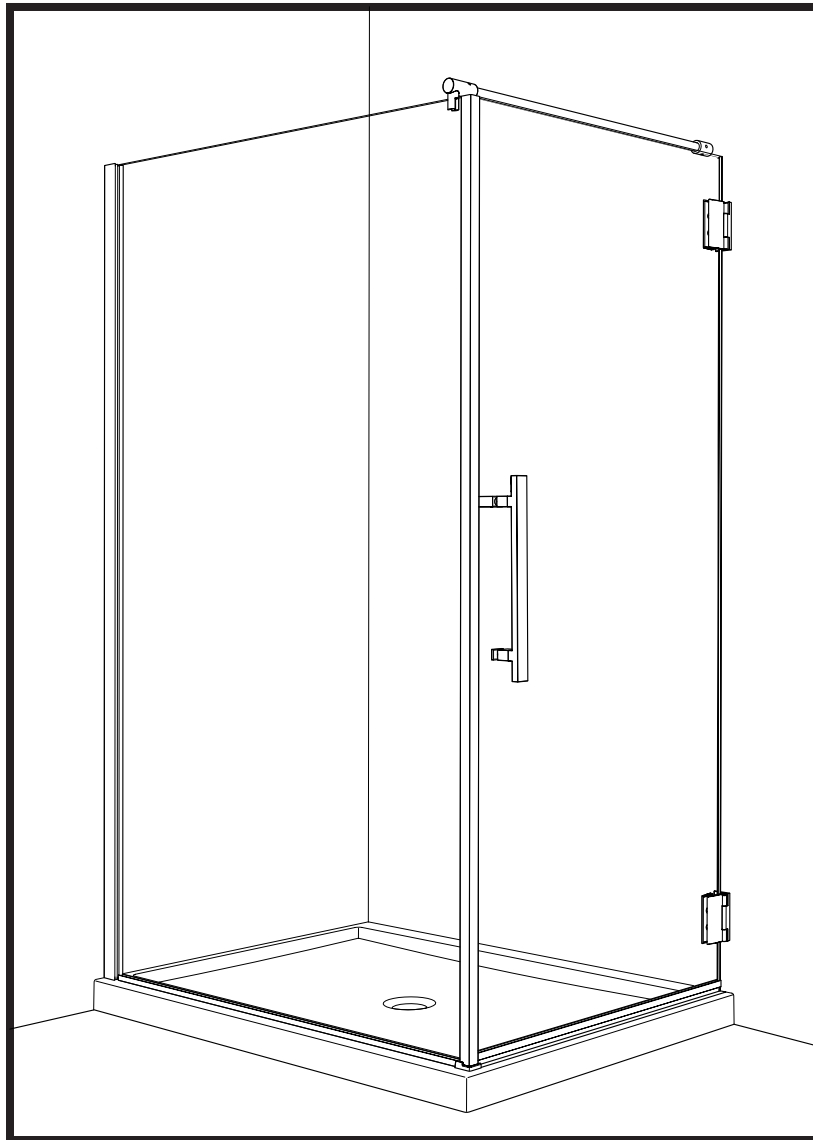

02/2015

Please keep this manual and product code number for future reference and for ordering replacement parts if necessary.

Veillez conserver ce manuel et le code de produit pour des références futures, et au besoin, la commande de pièces de rechange.

GENERAL INSTRUCTIONS

- Read this manual carefully and completely before proceeding.
- It is recommended that you wear safety glasses at all times during the installation.

En

INSTALLATION OVER CERAMIC TILES

- If your shower door is to be installed over ceramic tiles, the tiles should lay completely under the wall jamb.
- Silicone should be used to seal the gap where the ceramic tiles meet the fixed panel.

NOTICE

- Caulking: no sealant is required inside the shower, unless otherwise stated.
- Some models are equipped with clear sealing gaskets.

CARE FOR YOUR SHOWER DOOR

- Never use scouring powder pads or sharp instruments on metal pieces or glass panels. An occasional wiping down with a mild soap diluted in water is all that is needed to keep the panels and aluminum parts looking new.
- We recommend wiping the glass panels with a squeegee after each use.

INSTRUCTIONS GÉNÉRALES

- Lire attentivement et complètement le manuel d'installation avant de procéder.
- Il est recommandé de porter des lunettes de sécurité en tout temps lors de l'installation.

Fr

INSTALLATION SUR LES TUILES EN CÉRAMIQUE

- Si votre porte de douche doit être installée sur une bordure en céramique, le jambage doit reposer complètement sur cette dernière.
- Le calfeutrage doit être appliqué sur le côté extérieur de la douche où le panneau fixe rencontre la bordure en céramique.

NOTE

- Calfeutrage: aucun scellant n'est nécessaire à l'intérieur de la douche.
- Certains modèles sont dotés de joints d'étanchéité clairs.

L'ENTRETIEN DE VOTRE DOUCHE

- Ne jamais utiliser de poudre ou de tampon à récurer, ni d'instrument tranchant sur les parties en métal ou en verre. De temps à autre, il suffit de nettoyer la porte avec une solution d'eau et un détergent doux pour conserver l'aspect neuf des panneaux de verre et du cadre en aluminium.
- Nous recommandons de passer une raclette de douche sur les panneaux de verre après chaque utilisation.

TOOLS REQUIRED / OUTILS REQUIS

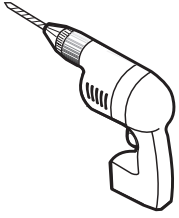

DRILL
PERCEUSE

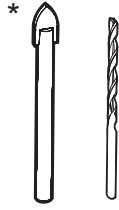

1/4" & 1/8" DRILL BITS
MÈCHE 1/4" & 1/8"



LONG NOSE LOCKING PLIERS
PINCE SERRE ÉTAU



PENCIL
CRAYON



MALLET
MAILLET



BLOCK
BLOC

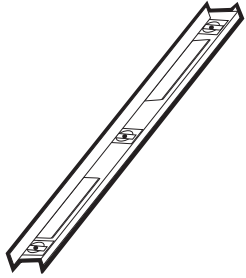

LEVEL
NIVEAU

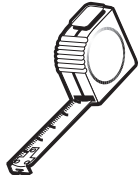

TAPE MEASURE
RUBAN À MESURER

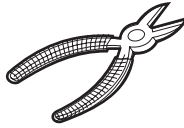

CUTTING PLIERS
PINCE COUPANTE



SCREWDRIVER
TOURNEVIS

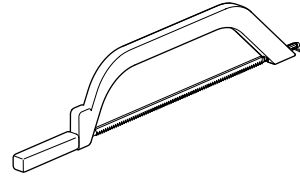

HACKSAW
SCIE À MÉTAUX

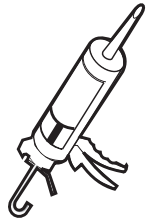

SILICONE
SCCELLANT

* Use a 1/4" drill bit when drilling into ceramic tiles

* Utiliser une mèche de 1/4" pour percer des tuiles en céramique.

POSSIBLE CONFIGURATIONS / CONFIGURATIONS POSSIBLES

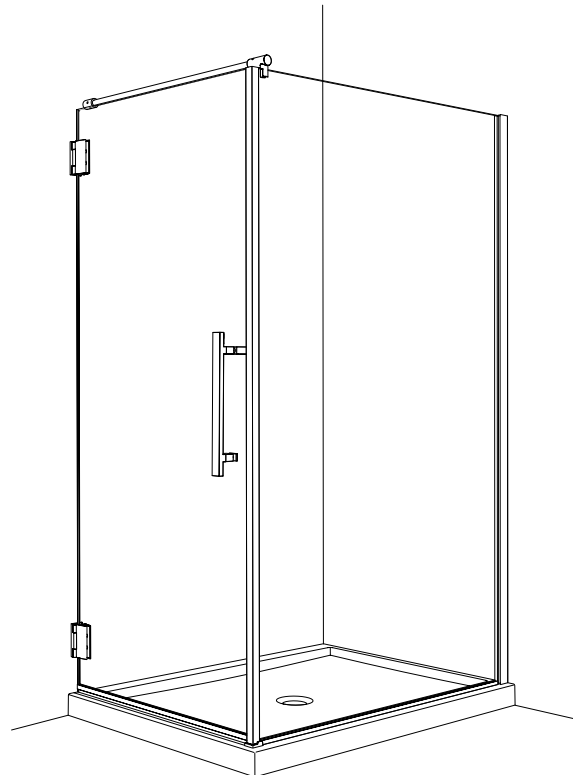
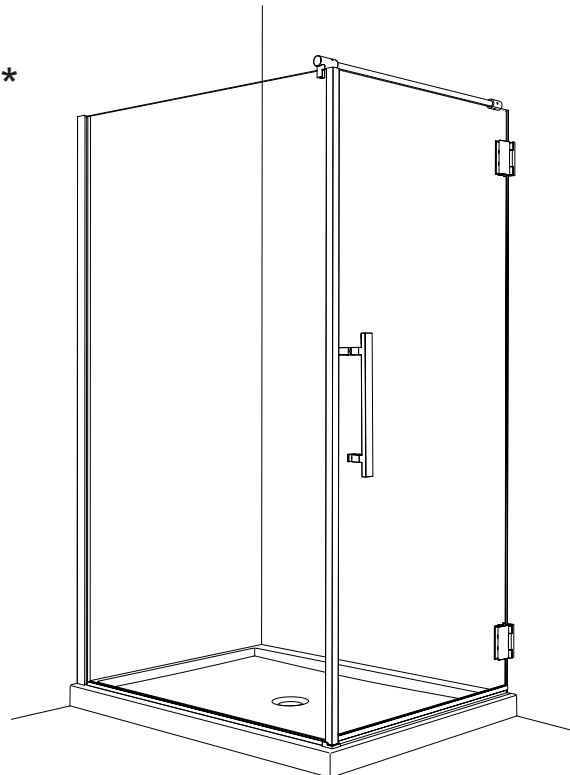

* This configuration illustrated in this manual.

* Cette configuration est illustrée dans ce manuel.

PARTS LISTING / LISTE DES PIÈCES

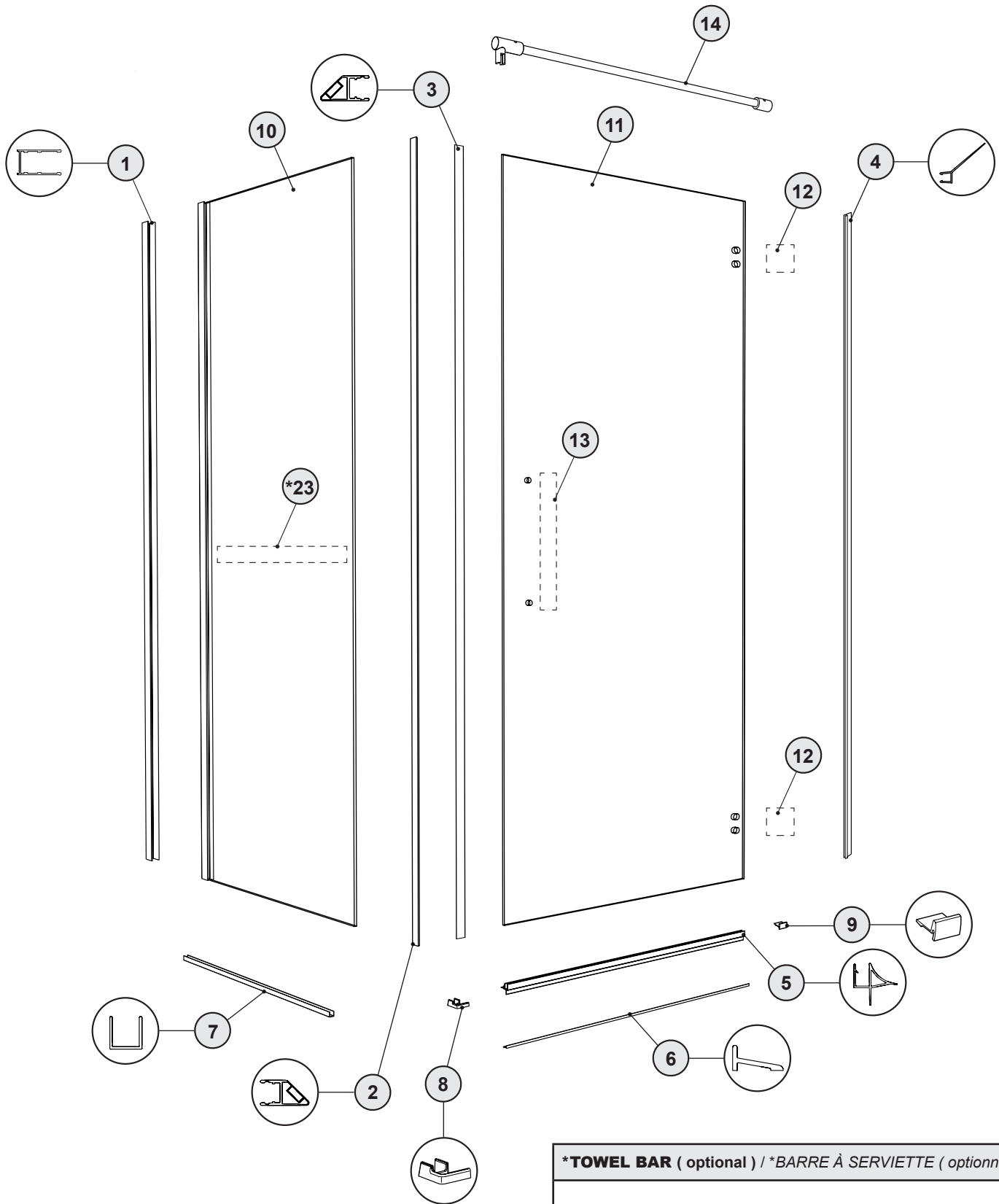

***TOWEL BAR (optional) / *BARRE À SERVIETTE (optionnelle)**

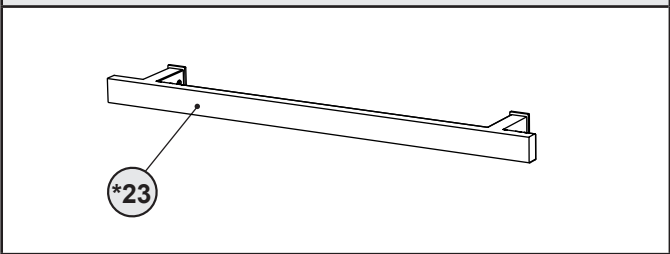

PARTS LISTING / LISTE DES PIÈCES

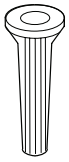

15



16



17



18



19

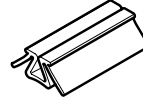

20



21



22

ITEM	PARTS LISTING / LISTE DES PIÈCES	QTY
1	WALL JAMB / JAMBAGE	1
2	MAGNETIC RETURN PANEL GASKET / JOINT MAGNÉTIQUE DU PANNEAU DE RETOUR	1
3	MAGNETIC DOOR GASKET / JOINT MAGNÉTIQUE DE LA PORTE	1
4	SIDE GASKET / JOINT LATÉRAL	1
5	BOTTOM DOOR GASKET / JOINT INFÉRIEUR DE LA PORTE	1
6	THRESHOLD / SEUIL	1
7	U-CHANNEL / PROFILÉ EN «U»	1
8	CORNER THRESHOLD ANCHOR / ANCRAGE DU SEUIL DE COIN	1
9	THRESHOLD ANCHOR / ANCRAGE DU SEUIL	1
10	RETURN PANEL / PANNEAU DE RETOUR	1
11	DOOR PANEL / PANNEAU DE PORTE	1
12	HINGE (see chart below) / CHARNIÈRE (voir le tableau ci-dessous)	2
13	HANDLE (see chart below) / POIGNÉE (voir le tableau ci-dessous)	1
14	SUPPORT BAR / BARRE DE SUPPORT	1
15	WALL PLUGS / CHEVILLES	4
16	PAN SELF-DRILLING SCREW / VIS PAN AUTO-PERÇANTE # 8 (3/8")	3
17	PAN SELF-DRILLING SCREW / VIS PAN AUTO-PERÇANTE # 8 (1 1/4")	3
18	BACK SCREW CAP / L'ARRIÈRE DU CAPUCHON COUVRE-VIS	4
19	SCREW CAP / CAPUCHON COUVRE-VIS	4
20	2" SPACING BLOCK / BLOC ESPACEUR 2"	2
21	CLEAR SETTING BLOCK (1/16") / BLOC NIVEAU TRANSPARENT (1/16")	2
22	CLEAR SETTING BLOCK (1/8") / BLOC NIVEAU TRANSPARENT (1/8")	2
*23	*TOWEL BAR / *BARRE À SERVIETTE	*1

12

HINGE OPTIONS / SÉLECTION DES CHARNIÈRES

Q	M	T

13

HANDLE OPTIONS / SÉLECTION DES POIGNÉES

A	B	C	D

1 MARK THE PLACEMENT AREA ON THE BASE / MARQUER LA ZONE DE POSITIONNEMENT SUR LA BASE

MODEL MODÈLE	DIM A = FRONT OPENING DIM A = OUVERTURE DU DEVANT		DIM B = SIDE OPENING DIM B = OUVERTURE DU CÔTÉ	
	MIN	MAX	MIN	MAX
3232	29" / 737mm	29 3/8" / 746mm	29 3/4" / 756mm	30 1/4" / 768mm
3636	33 7/16" / 849mm	33 13/16" / 859mm	33 1/8" / 841mm	33 5/8" / 854mm
3642	33 7/16" / 849mm	33 13/16" / 859mm	39 1/8" / 994mm	39 5/8" / 1006mm
3648	33 7/16" / 849mm	33 13/16" / 859mm	45 3/4" / 1162mm	46 1/4" / 1175mm

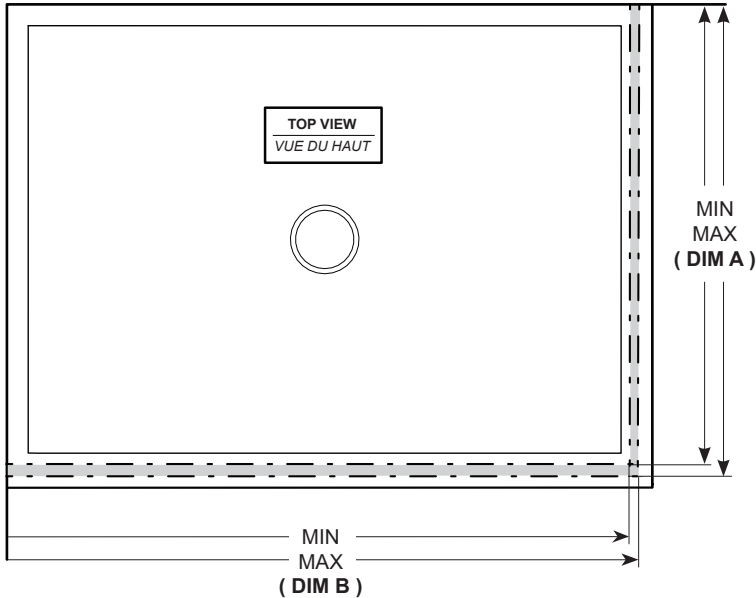

RECOMMENDED AREA FOR
SHOWER DOOR INSTALLATION.
ZONE RECOMMANDÉE POUR
L'INSTALLATION DE LA PORTE DE DOUCHE.



!

THE INSTALLATION SHOWN IS BASED ON PLUMB FINISHED WALLS AND A LEVELLED BASE. IF THESE CONDITIONS ARE NOT MET, PLEASE ADJUST ACCORDINGLY.

L'INSTALLATION ILLUSTRÉE EST BASÉE SUR DES MURS FINIS D'APLOMB ET UNE BASE DE DOUCHE NIVELÉE. SI CES CONDITIONS NE SONT PAS PRÉSENTÉES, VEUILLEZ AJUSTER EN CONSÉQUENCE.

2 MARK THE CENTER LINE / MARQUER LA LIGNE DU CENTRE

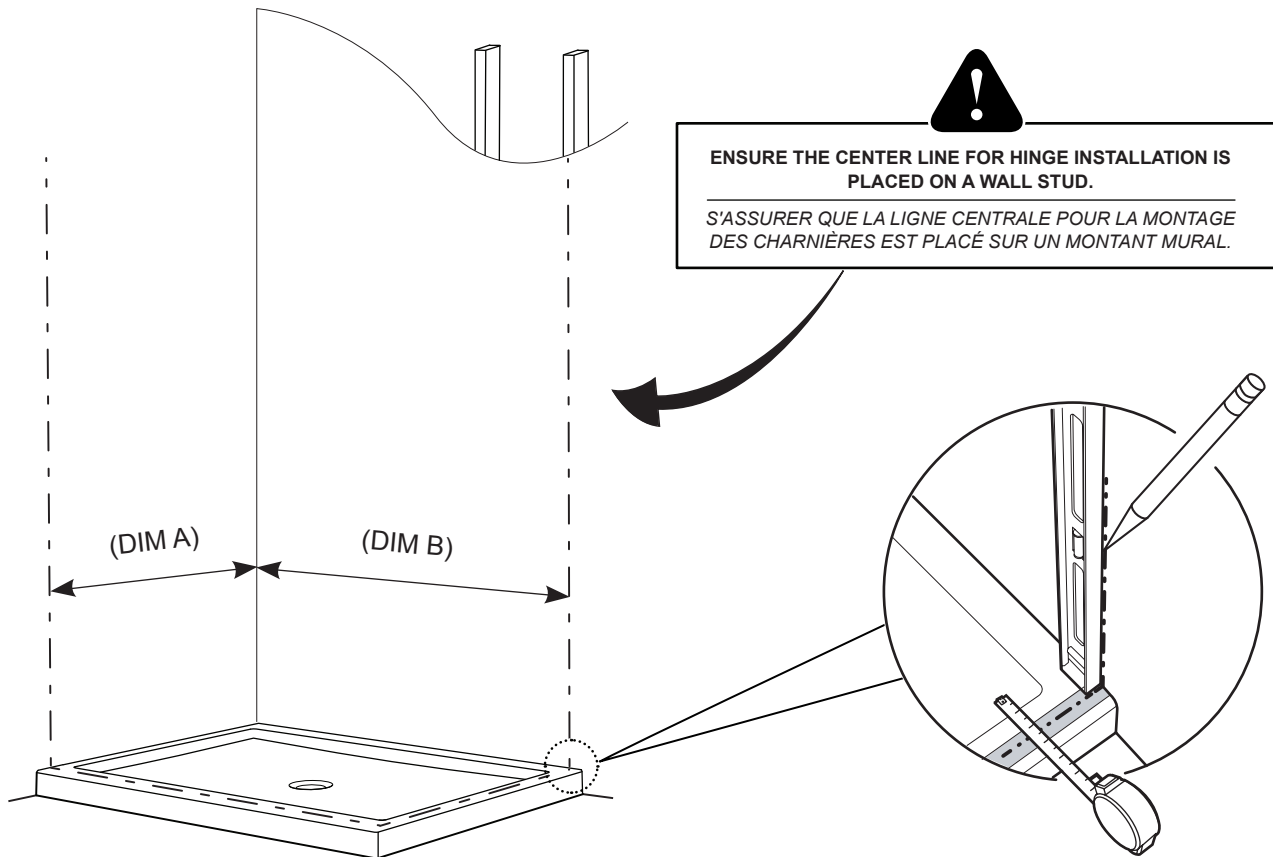

3 MARK EACH HINGE LOCATION / MARQUER L'EMPLACEMENT DES CHARNIÈRES

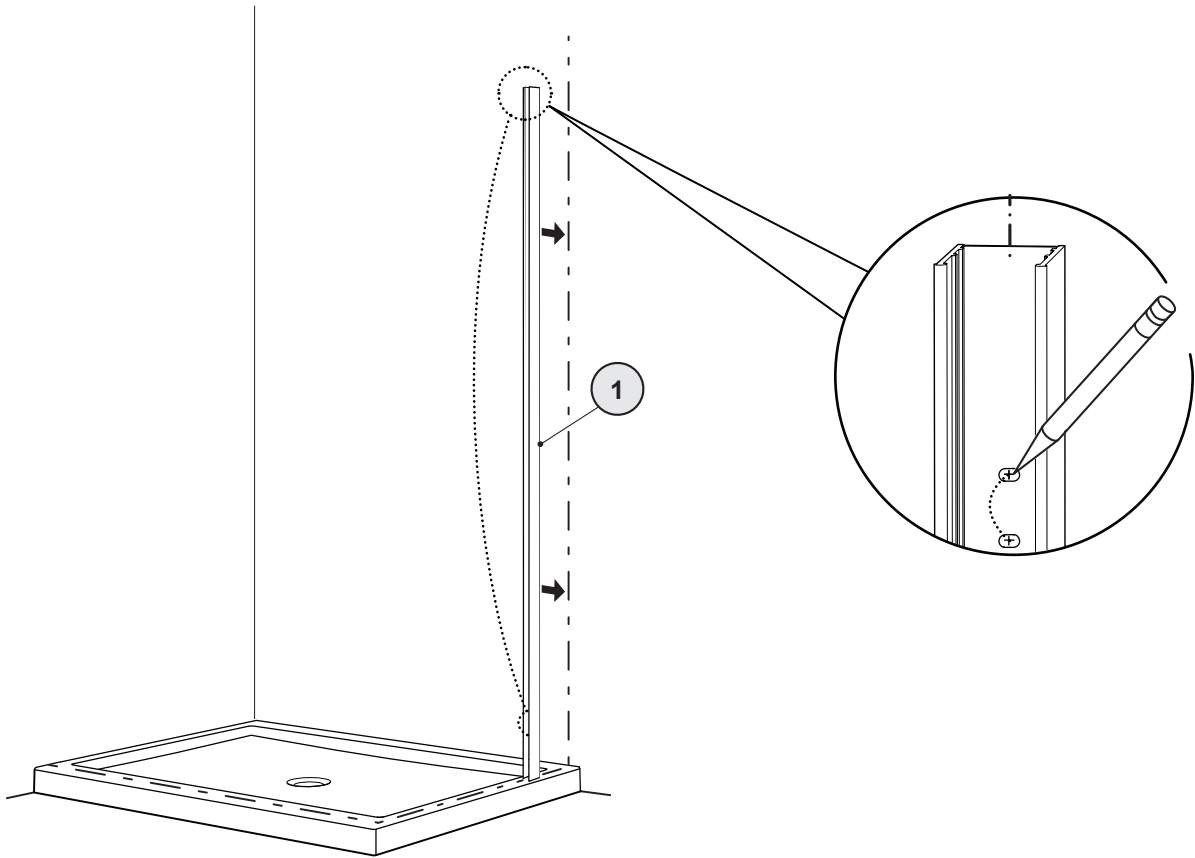

4 INSTALL THE WALL PLUGS / INSTALLER LES CHEVILLES

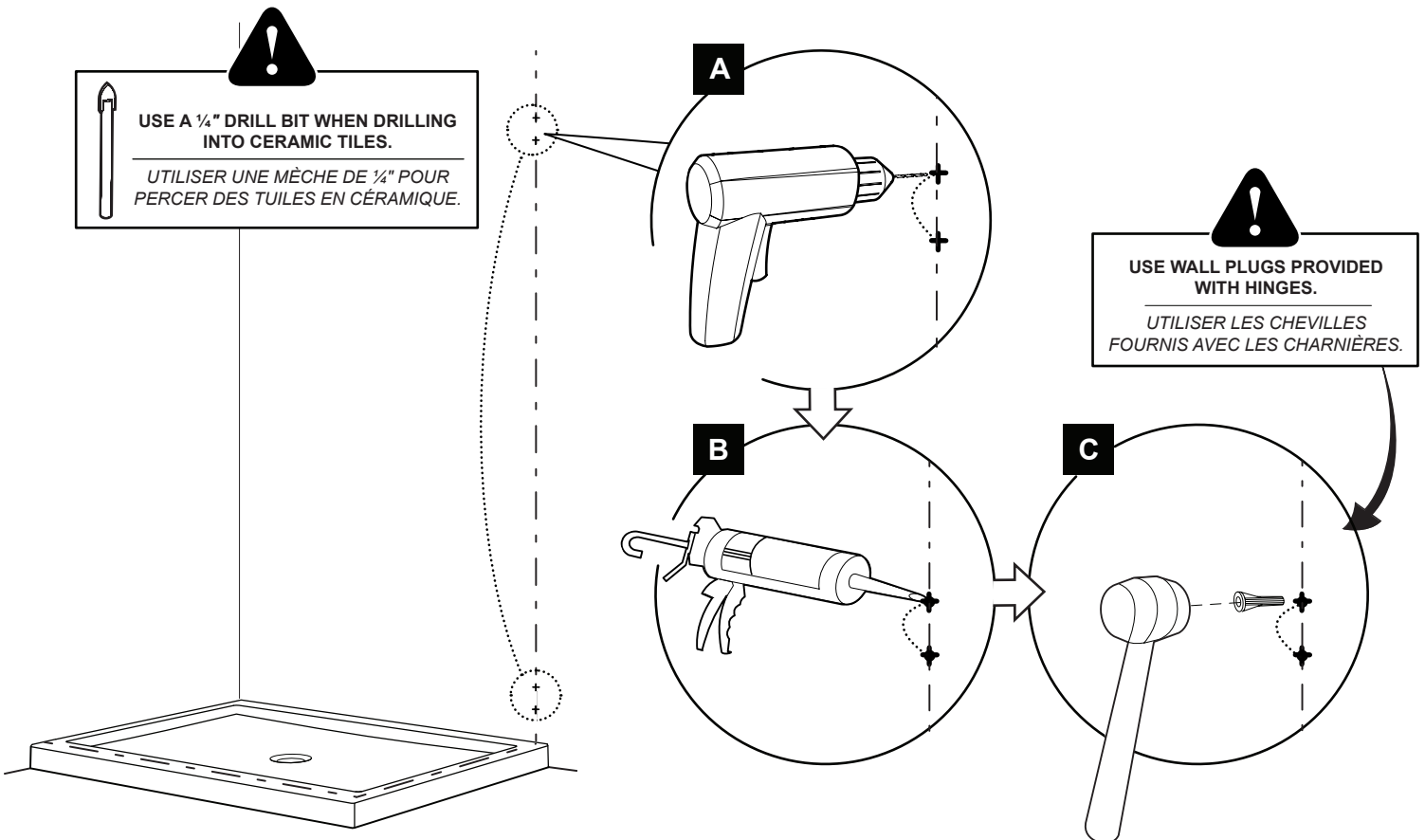

5 **INSTALL THE HINGES / INSTALLER LES CHARNIÈRES**

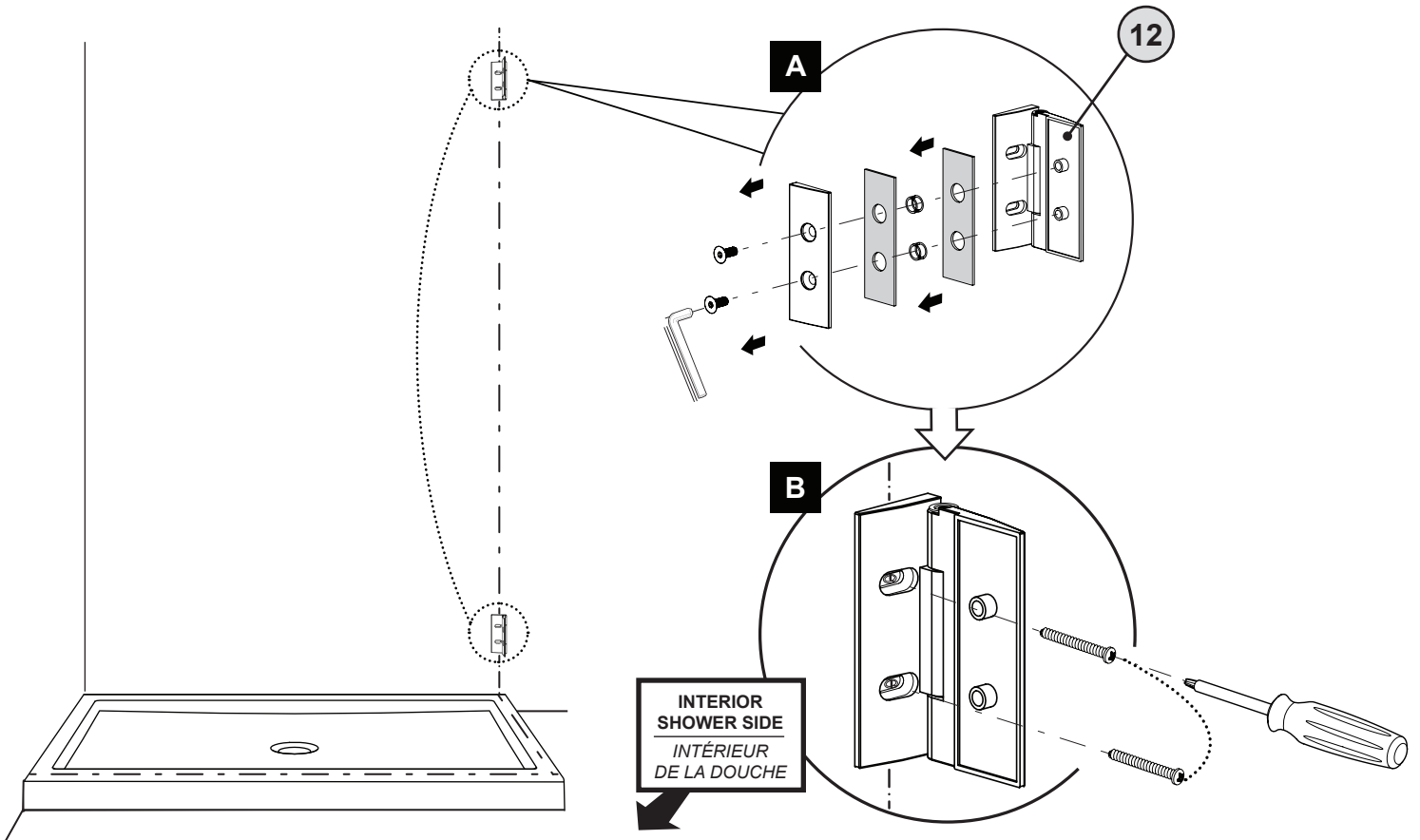

6.1 **CUT THE BOTTOM DOOR GASKET / COUPER LE JOINT INFÉRIEUR DE LA PORTE**

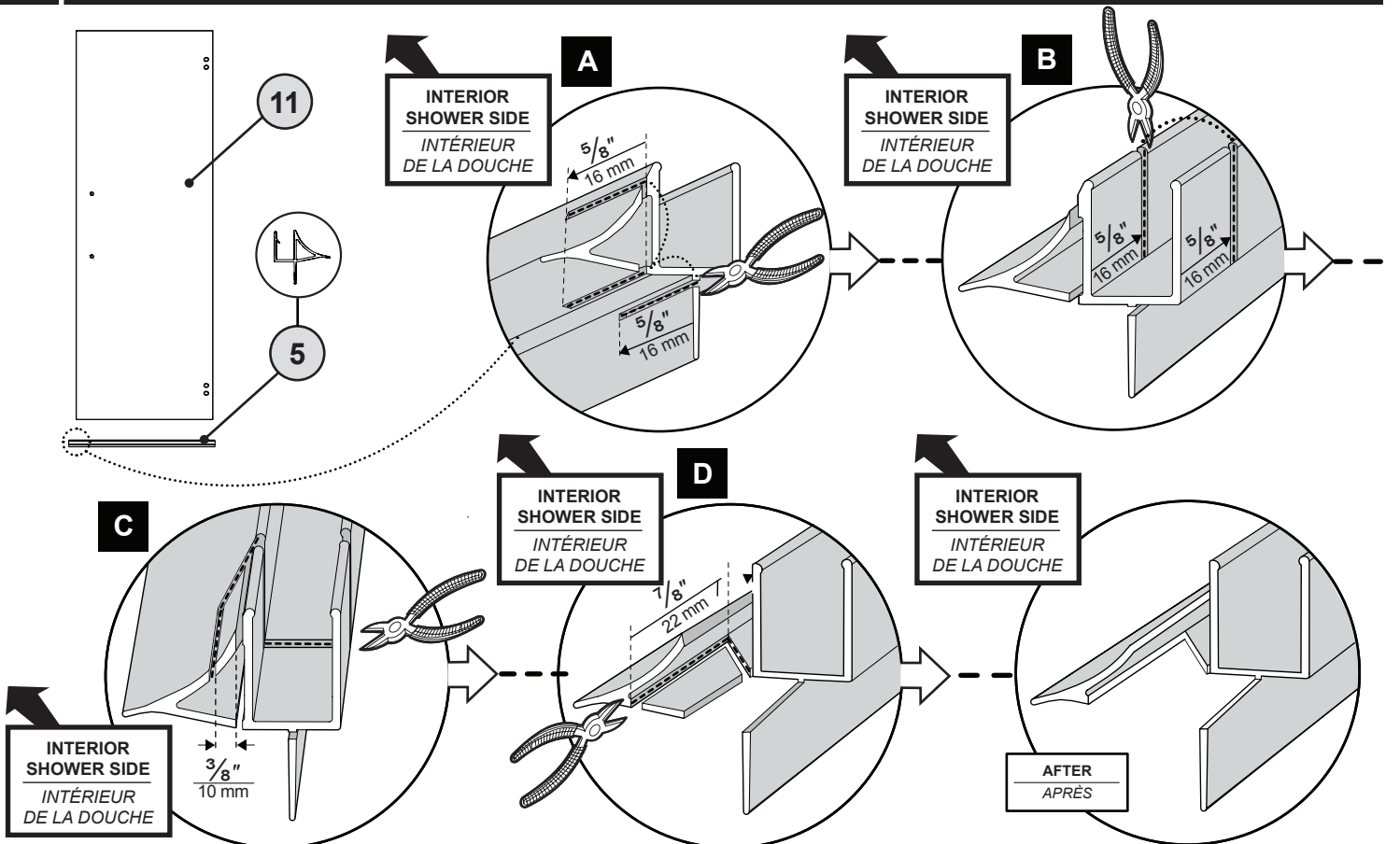

6.2 CUT THE BOTTOM DOOR GASKET (CONT'D) / COUPER LE JOINT INFÉRIEUR DE LA PORTE (SUITE)

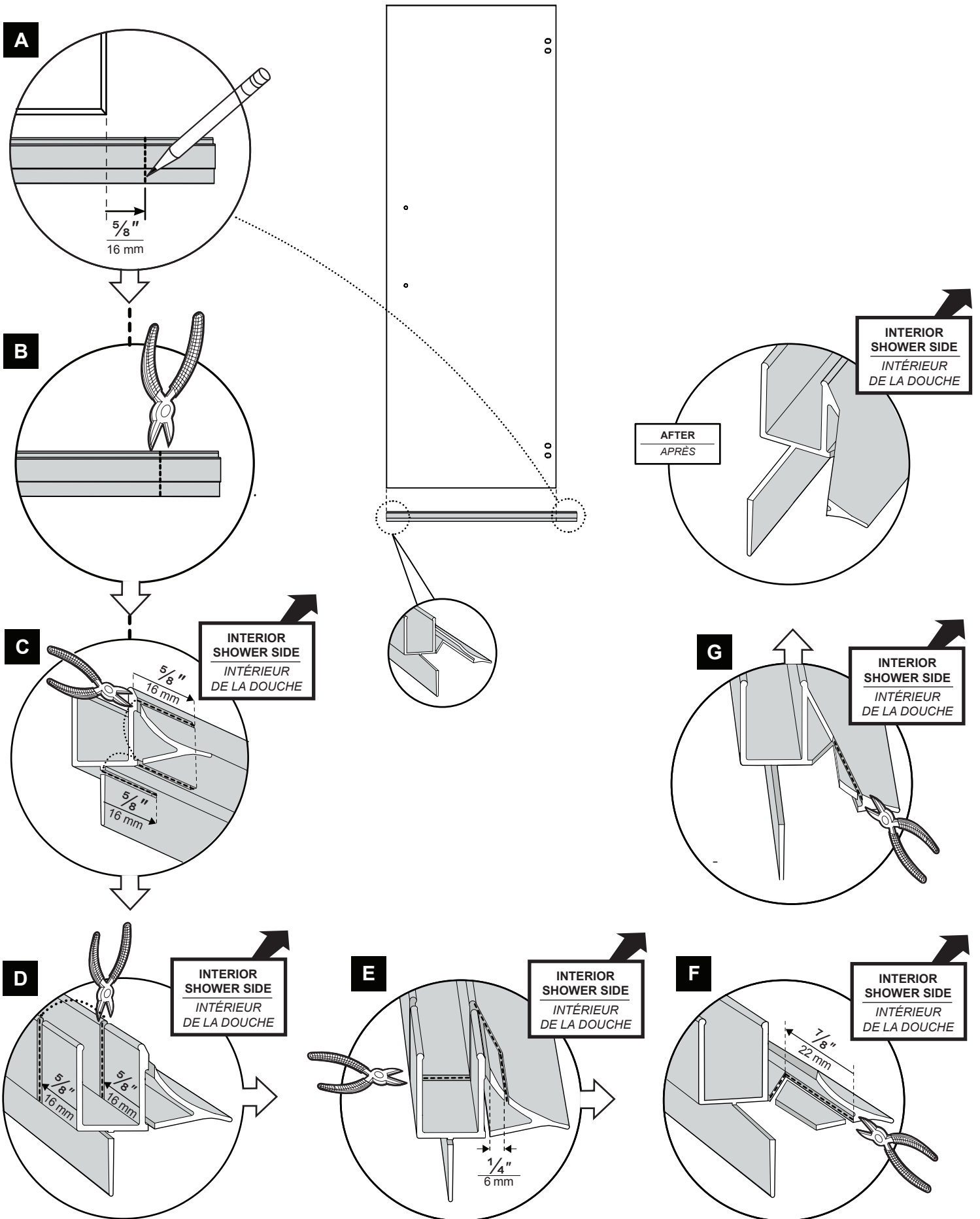

7 INSTALL THE DOOR GASKETS / INSTALLER LES JOINTS DE LA PORTE

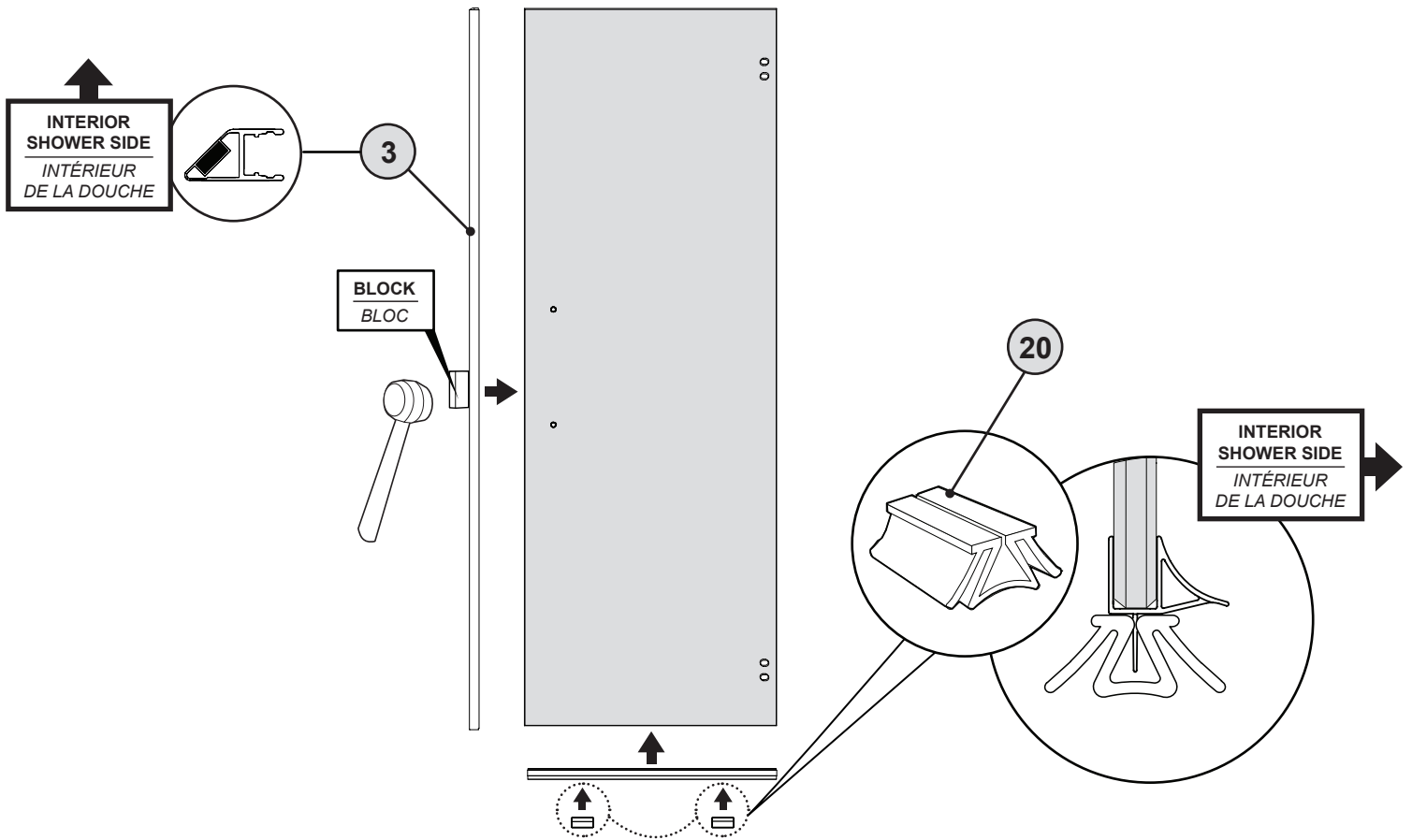

8 INSTALL THE DOOR / INSTALLER LA PORTE

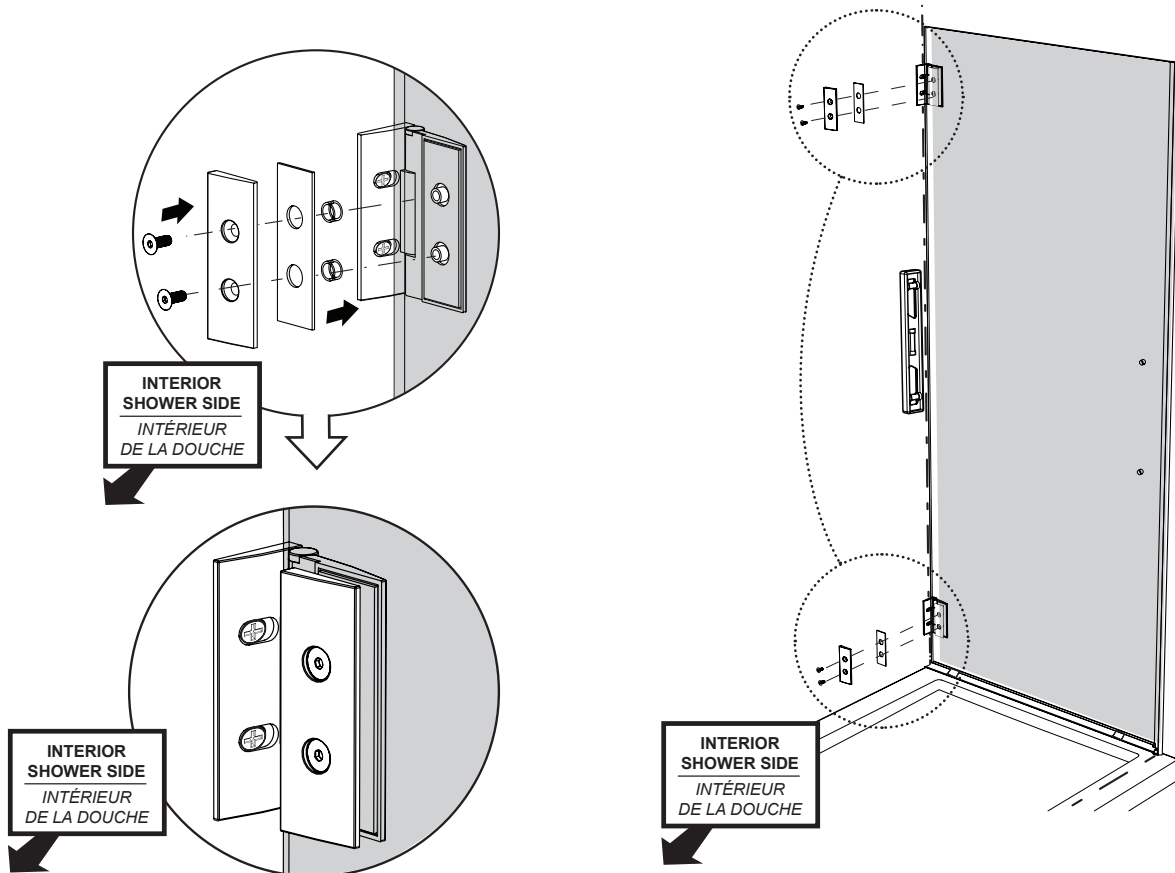

9 INSTALL THE DOOR GASKET / INSTALLER LE JOINT DE LA PORTE

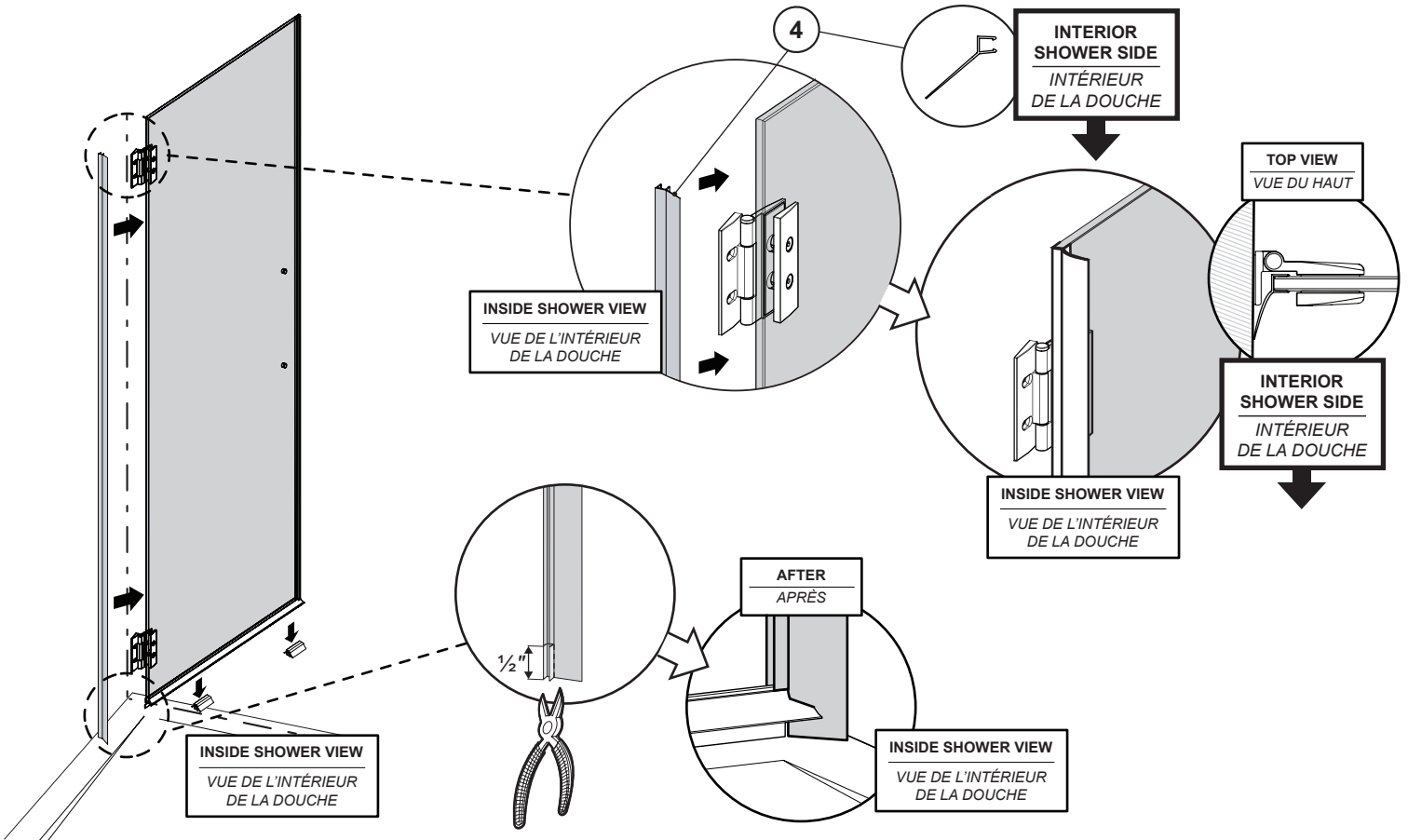

10 INSTALL THE WALL JAMB AND MAGNETIC GASKET TO THE RETURN PANEL
INSTALLER LE JAMBAGE ET LE JOINT MAGNÉTIQUE POUR LE PANNEAU DE RETOUR

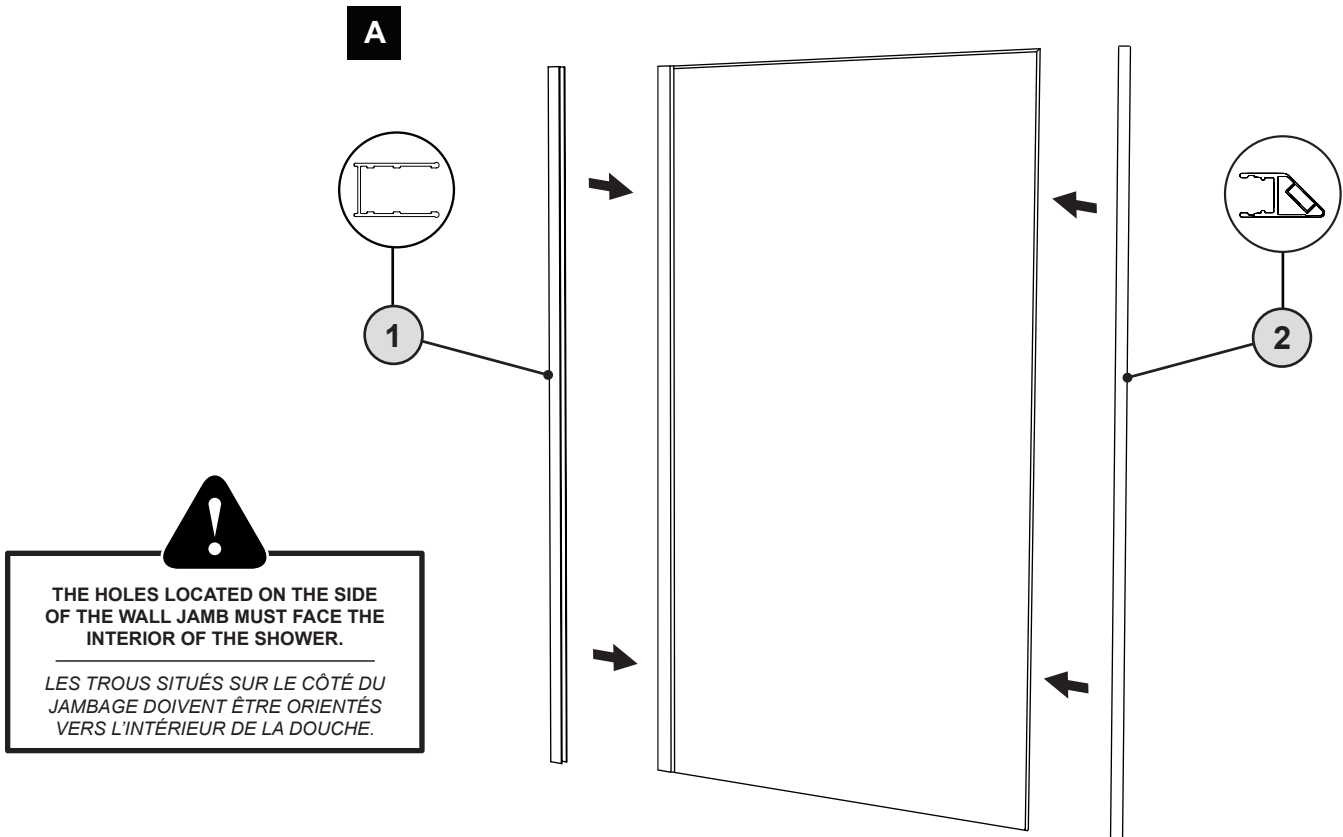

11 PLACE THE RETURN PANEL ON THE BASE / PLACER LE PANNEAU DE RETOUR SUR LA BASE

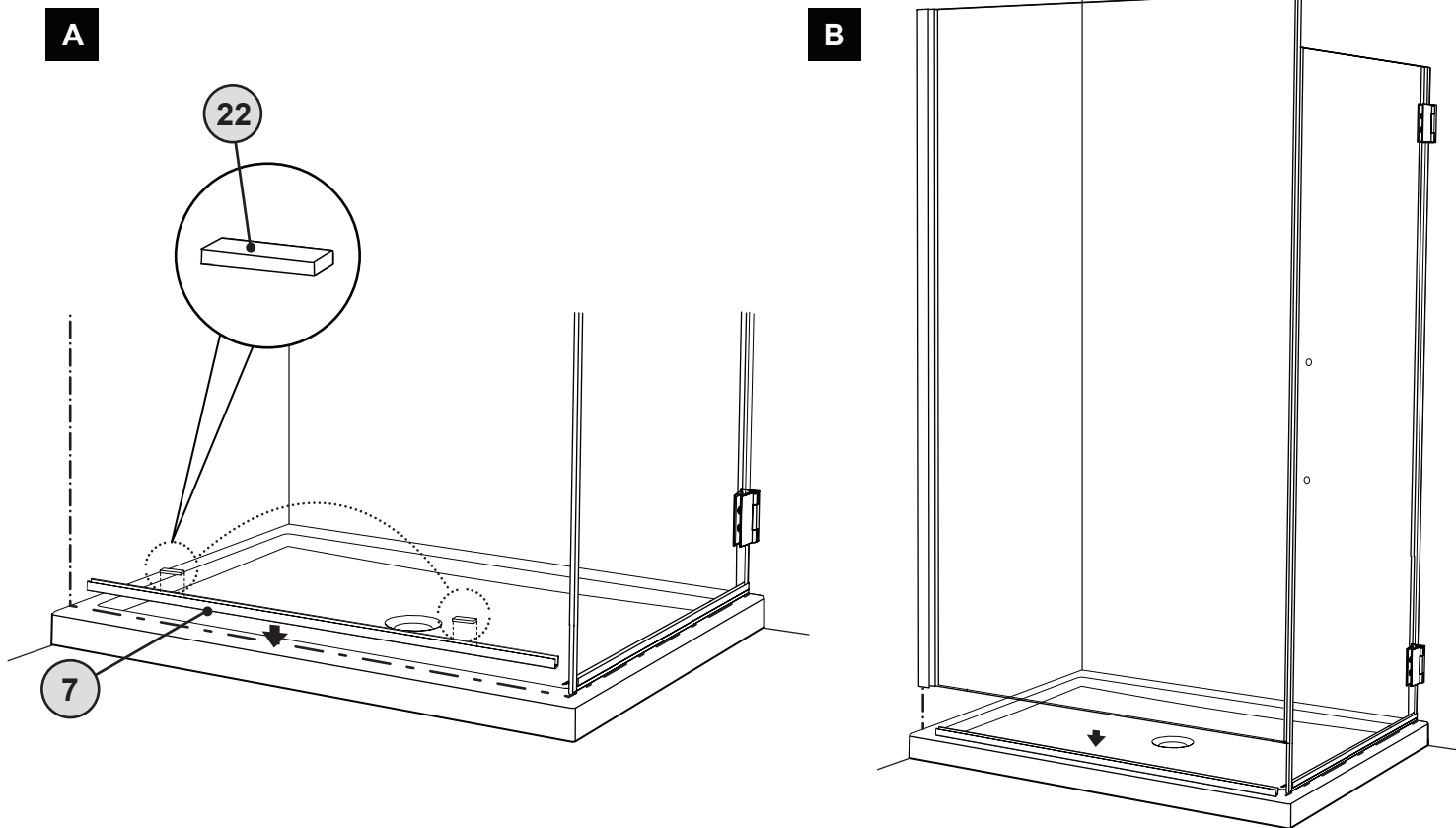

12 LEVEL AND ADJUST / NIVELER ET AJUSTER

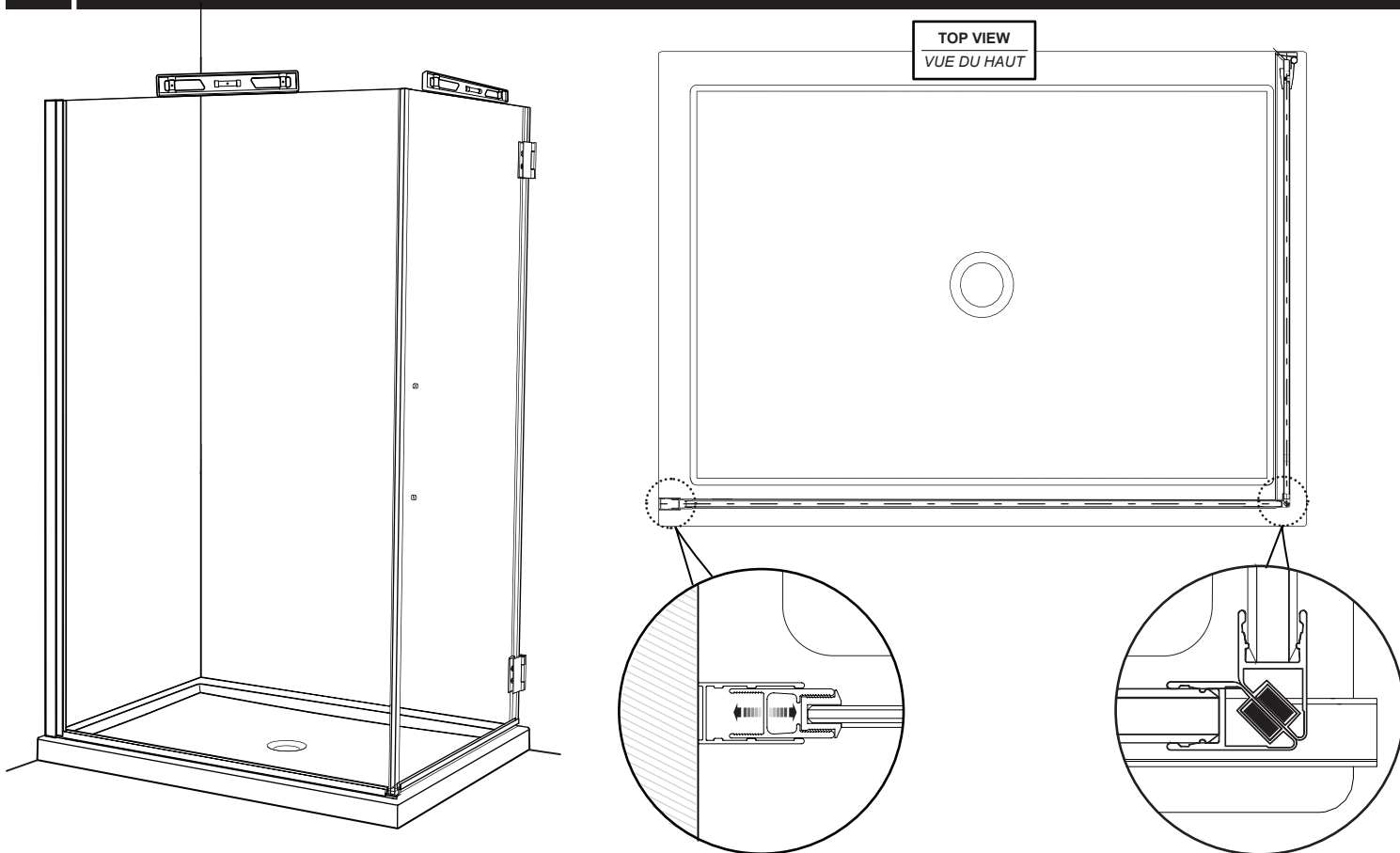

13 MARK THE U-CHANNEL AND WALL JAMB LOCATION / MARQUER L'EMPLACEMENT DU PROFILÉ EN «U» ET DU JAMBAGE

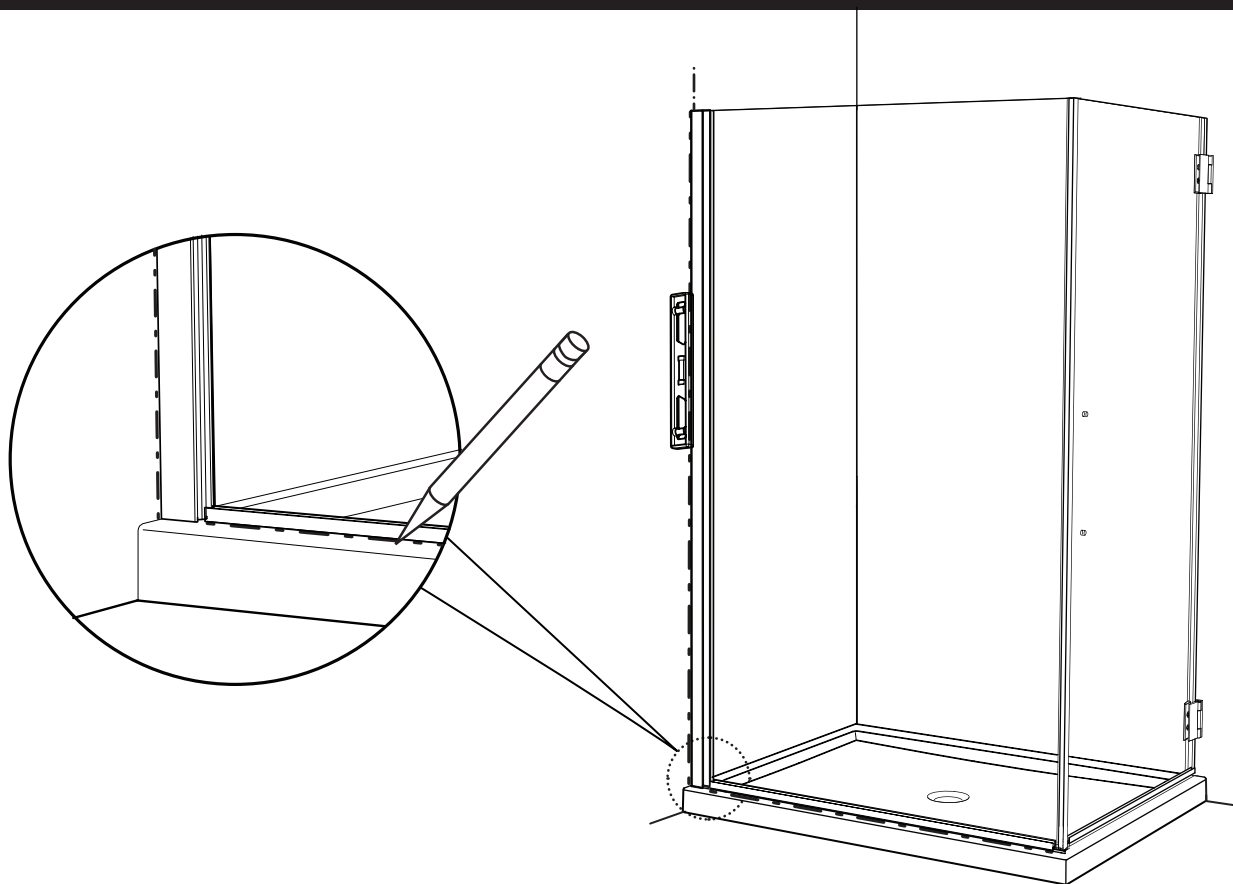

14 MARK THE WALL JAMB HOLES / MARQUER LES TROUS DU JAMBAGE

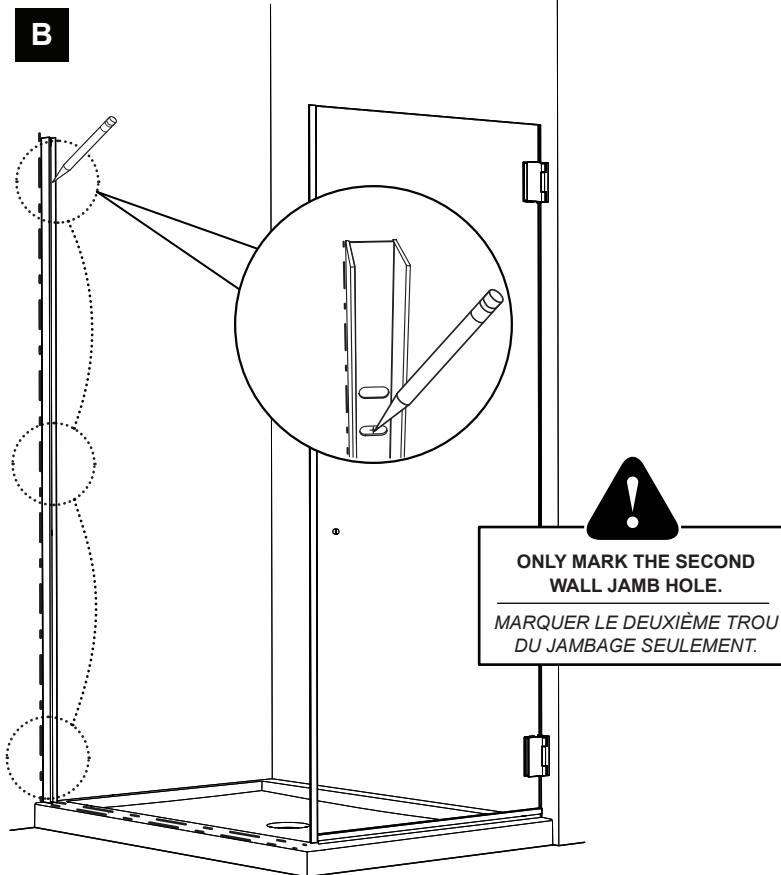
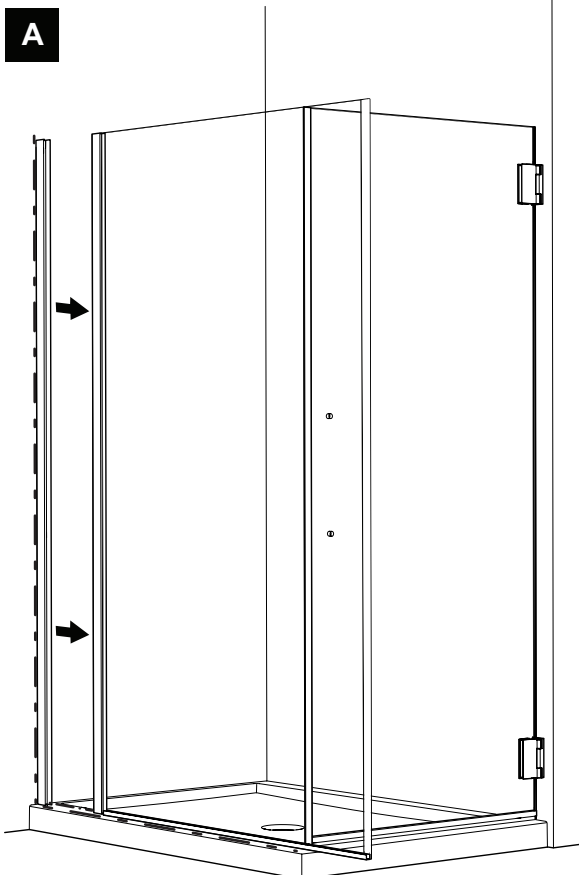

15 INSTALL THE WALL PLUGS / INSTALLER LES CHEVILLES

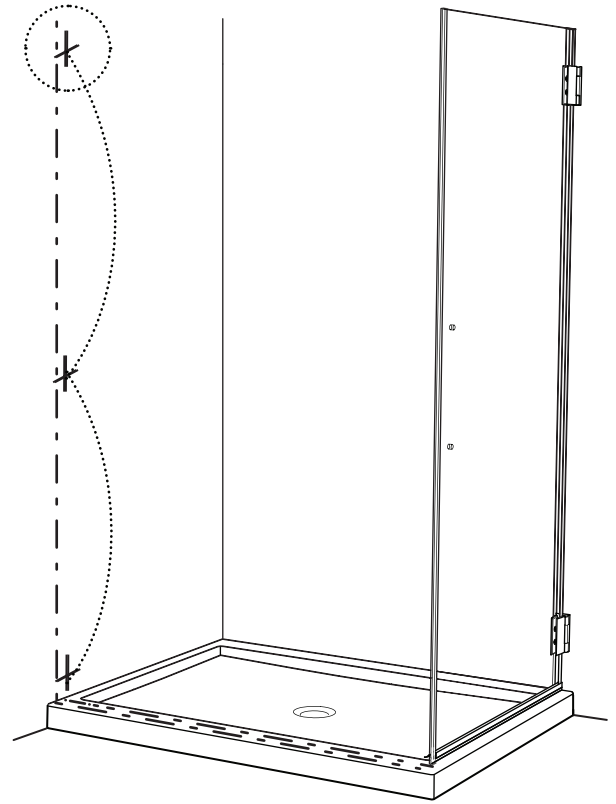
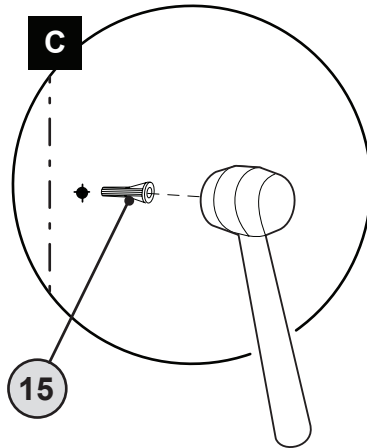
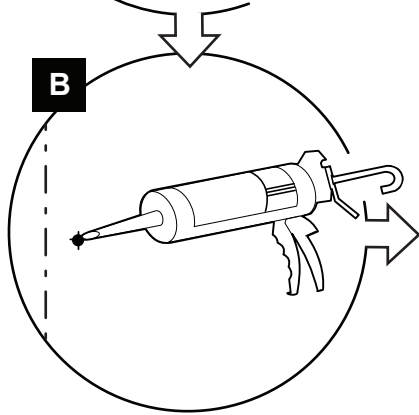
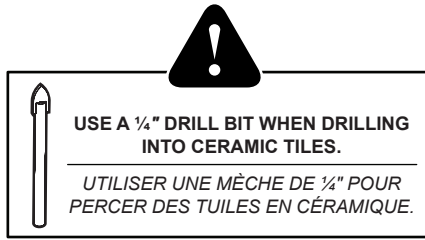
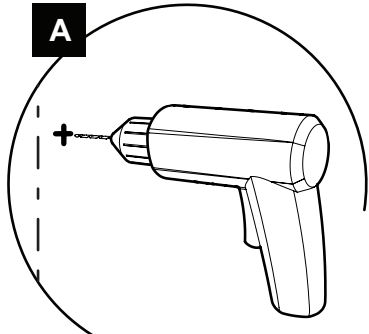

16 INSTALL THE WALL JAMB / INSTALLER LE JAMBAGE

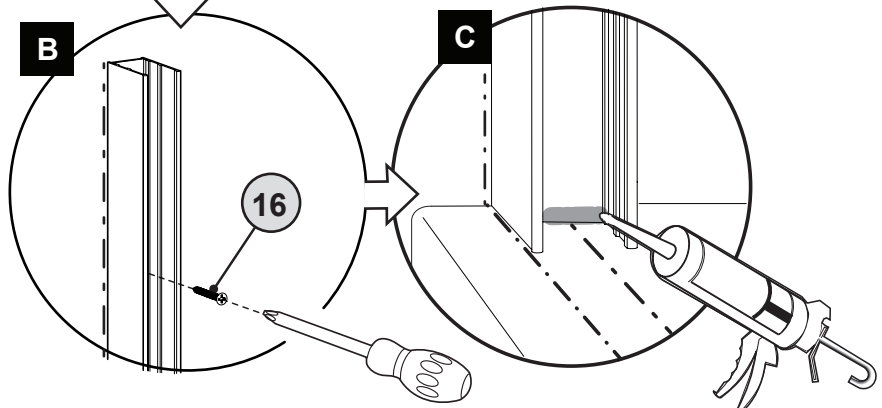
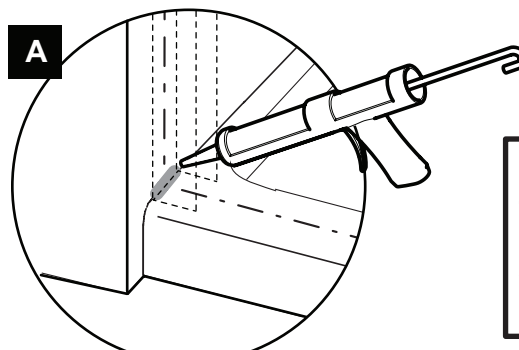
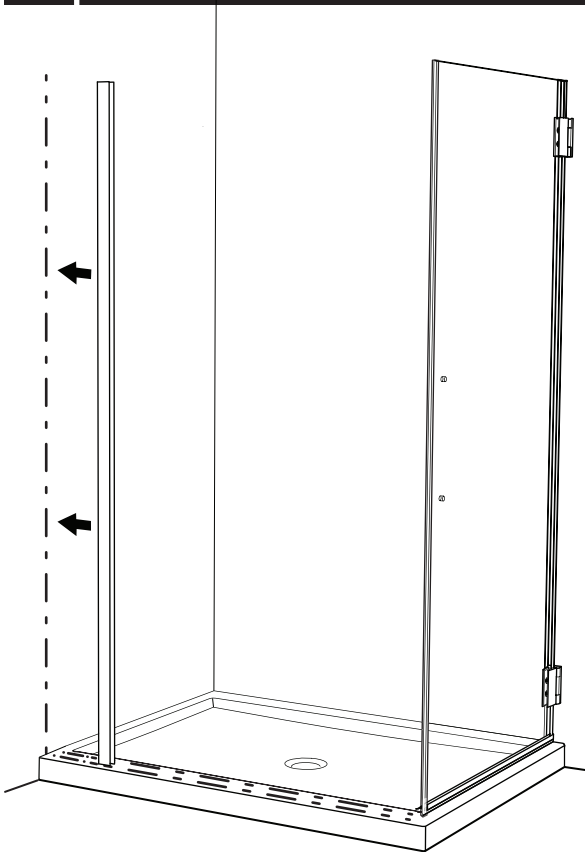

17 INSTALL THE U-CHANNEL / INSTALLER LE PROFILÉ EN «U»

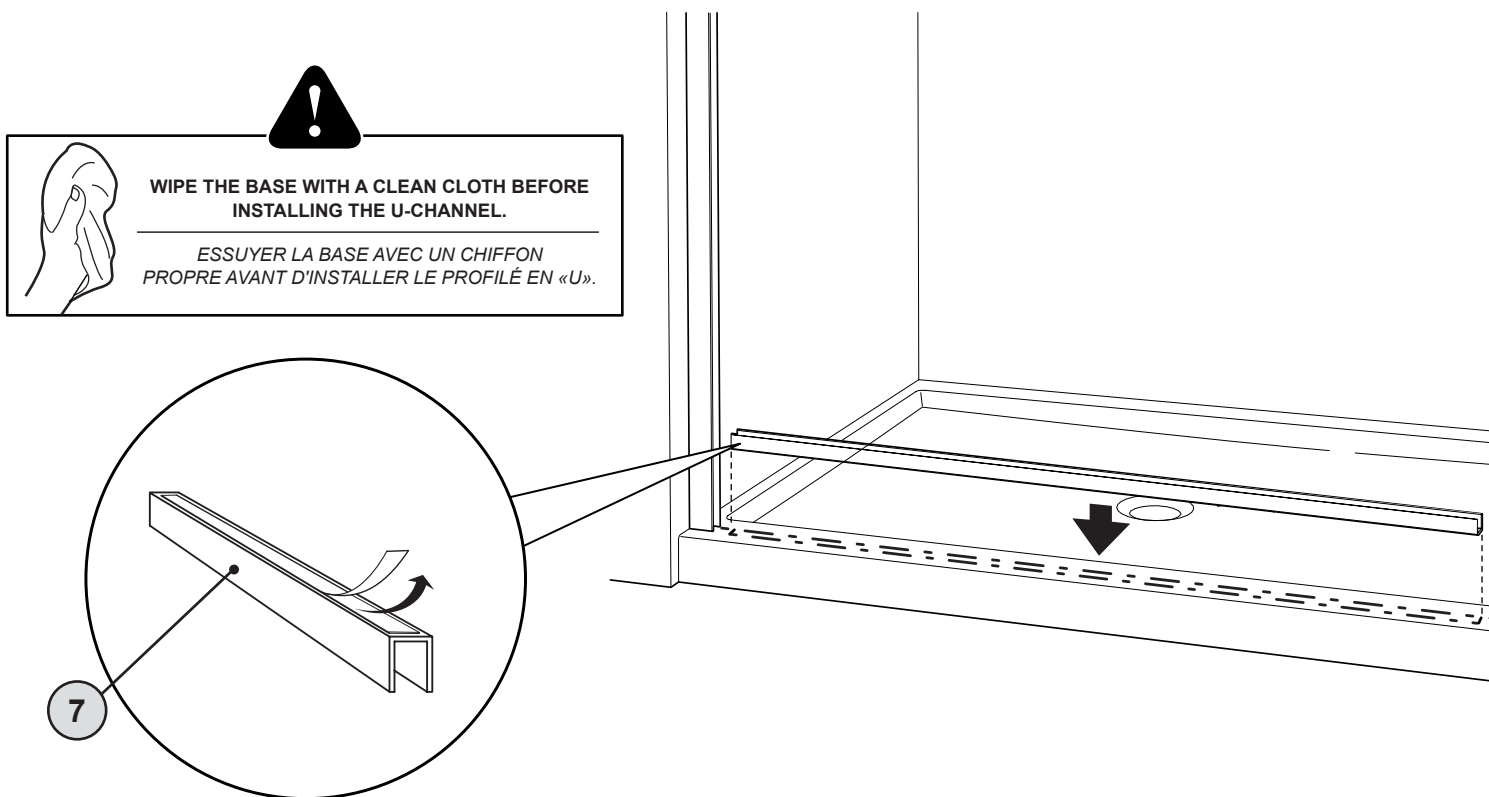

18 INSTALL THE FIXED PANEL / INSTALLER LE PANNEAU FIXE

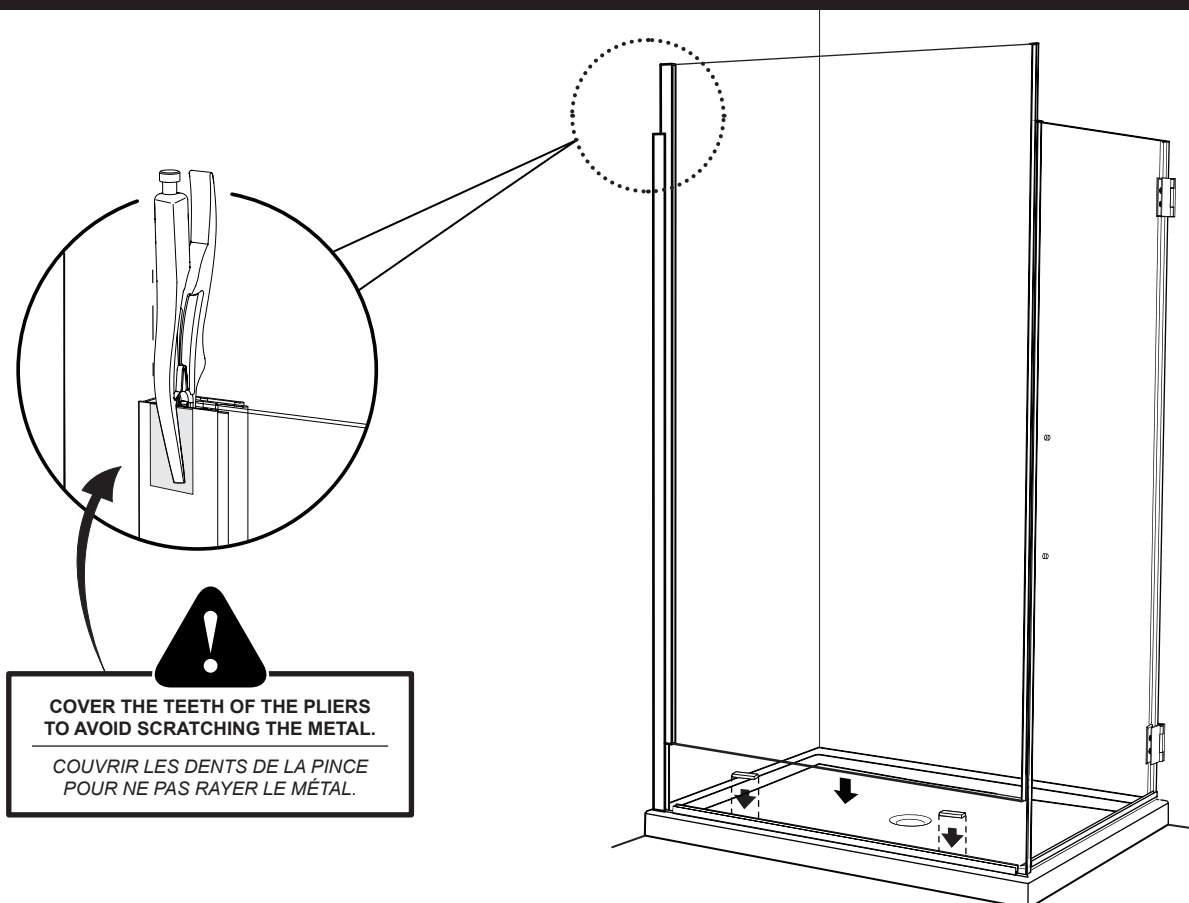

19 LEVEL AND SECURE THE EXPANDERS / NIVELER ET SÉCURISER LES EXTENSEURS

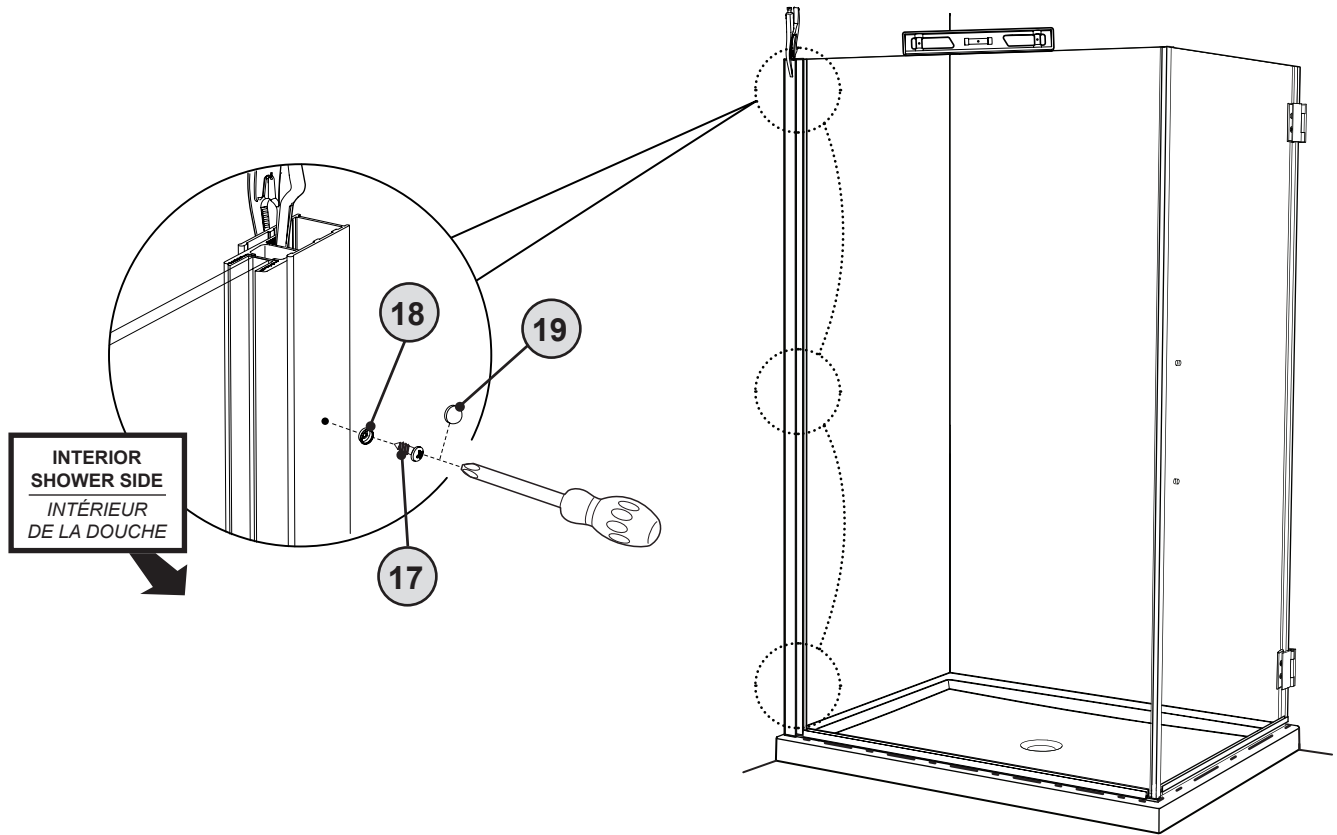

20 INSTALL THE HANDLE AND TOWEL BAR* / INSTALLER LA POIGNÉE ET LA BARRE À SERVIETTE*

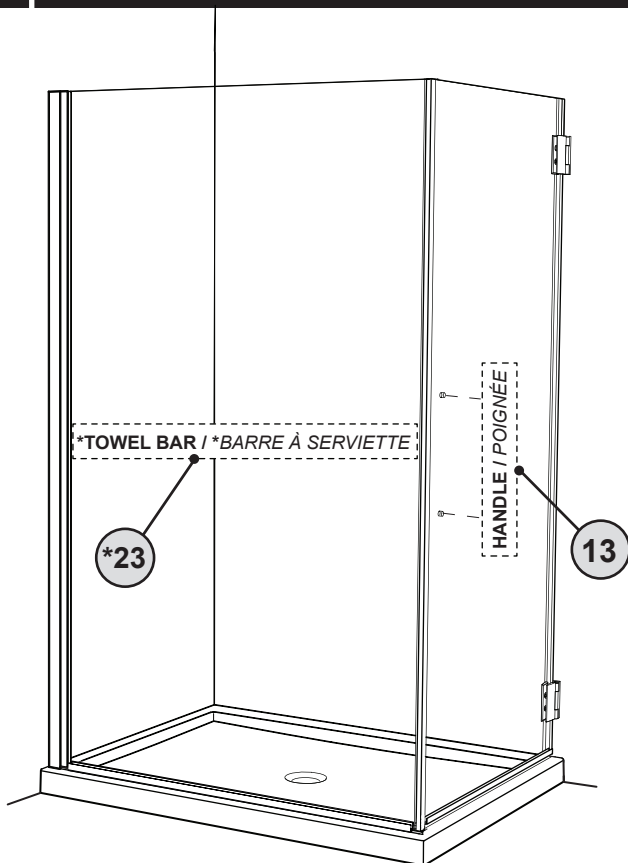



**SEE INSTRUCTIONS ENCLOSED WITH HANDLE FOR
INSTALLATION PROCEDURES.**

*VOIR LES INSTRUCTIONS QUI SONT ENFERMÉS
AVEC LA POIGNÉE POUR LES PROCÉDURES
D'INSTALLATION.*

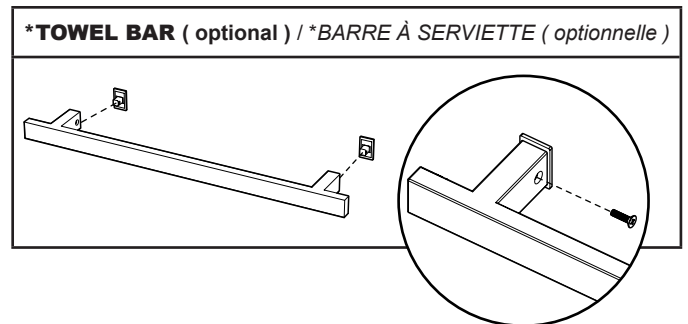

21 INSTALL THE CORNER THRESHOLD ANCHOR / INSTALLER L'ANCRAGE DU SEUIL DE COIN

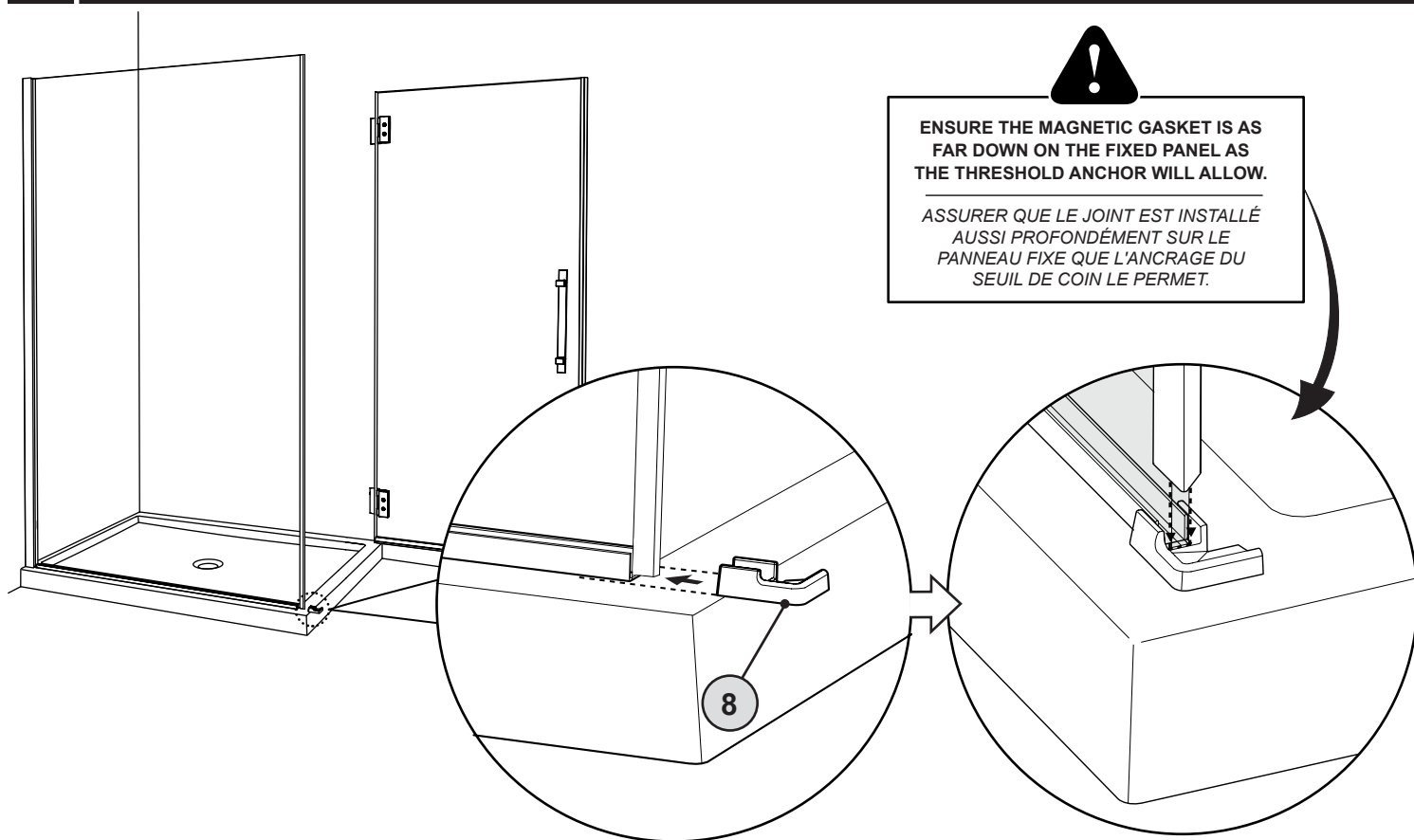

22 MARK THE SUPPORT BRACKET POSITION / MARQUER LA POSITION DU SUPPORT

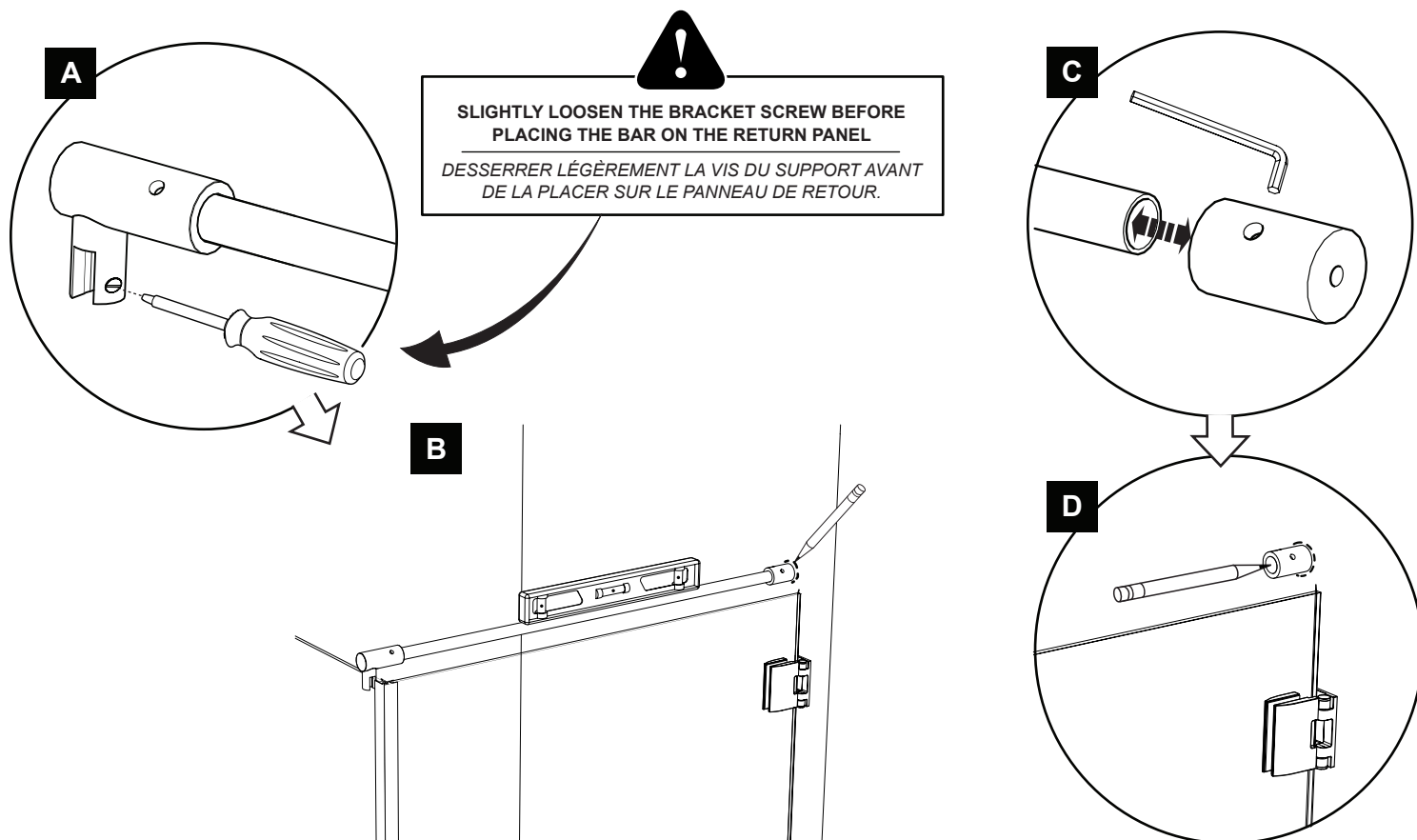

23 SECURE THE BRACKET / SÉCURISER LE SUPPORT

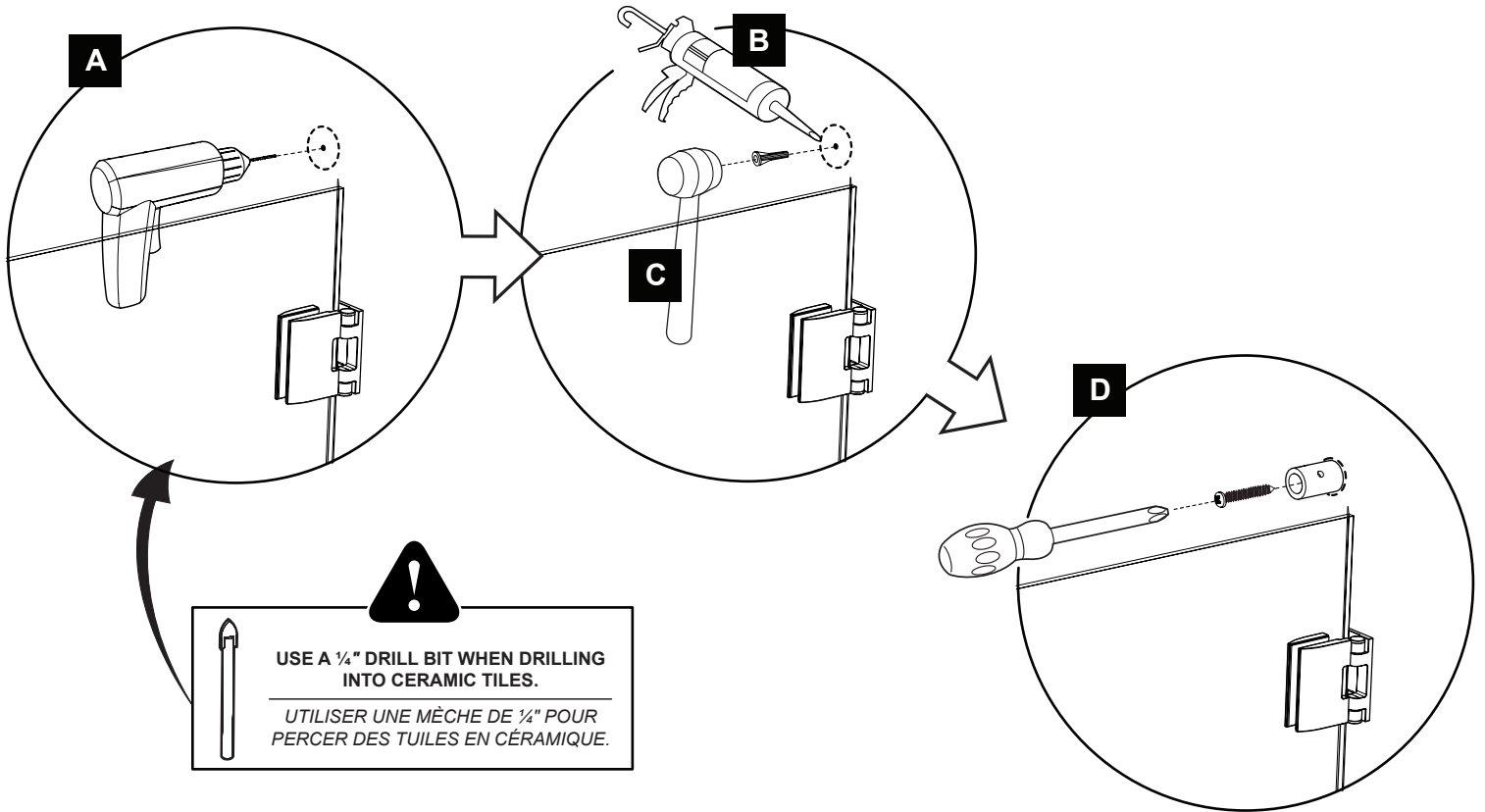

24 INSTALL THE SUPPORT BAR / INSTALLER LA BARRE DE SUPPORT

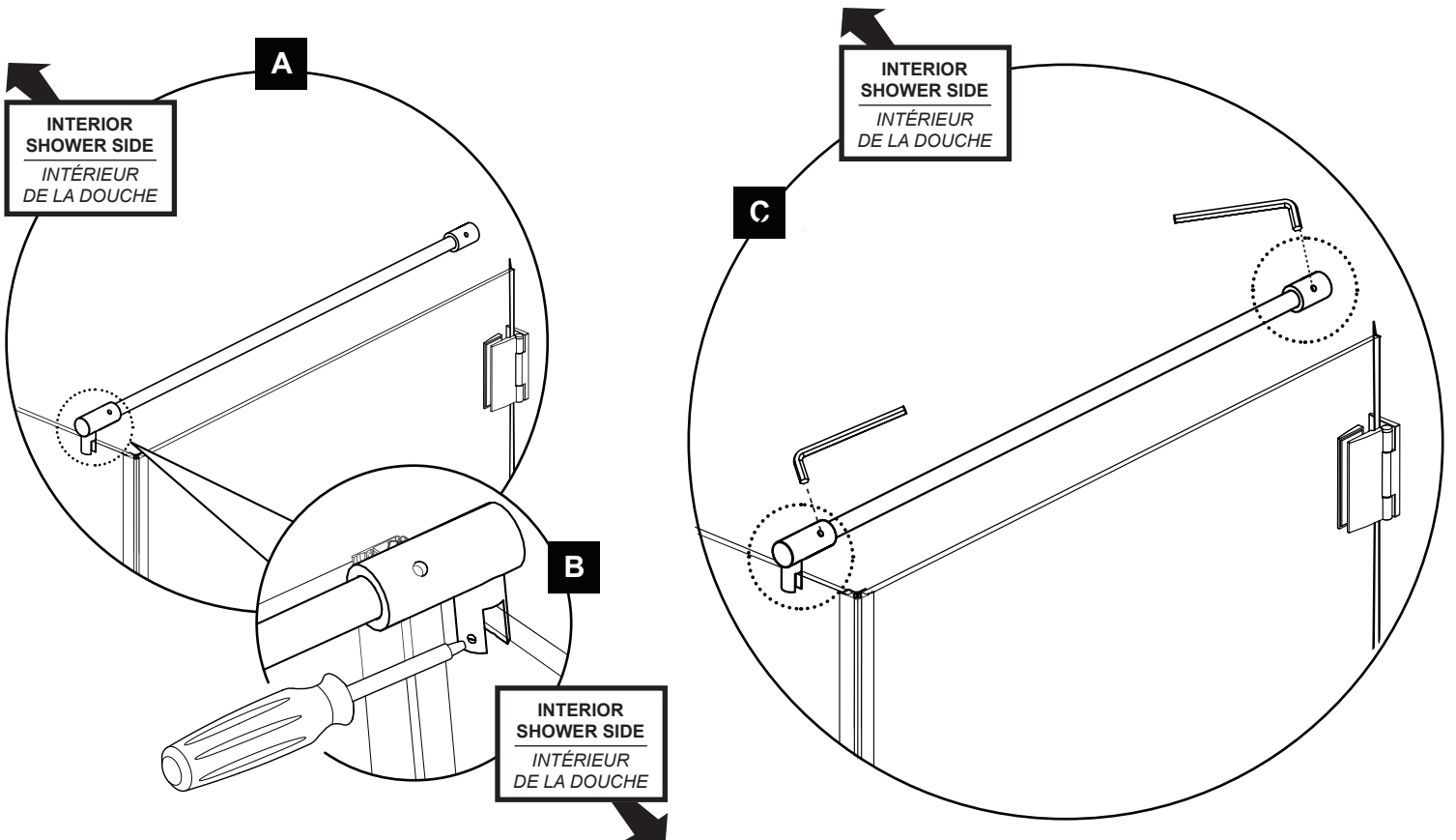



TRIM THRESHOLD IF NECESSARY BEFORE APPLYING SILICONE.
COUPER LE SEUIL SI NÉCESSAIRE AVANT D'APPLIQUER DU SILICONE.

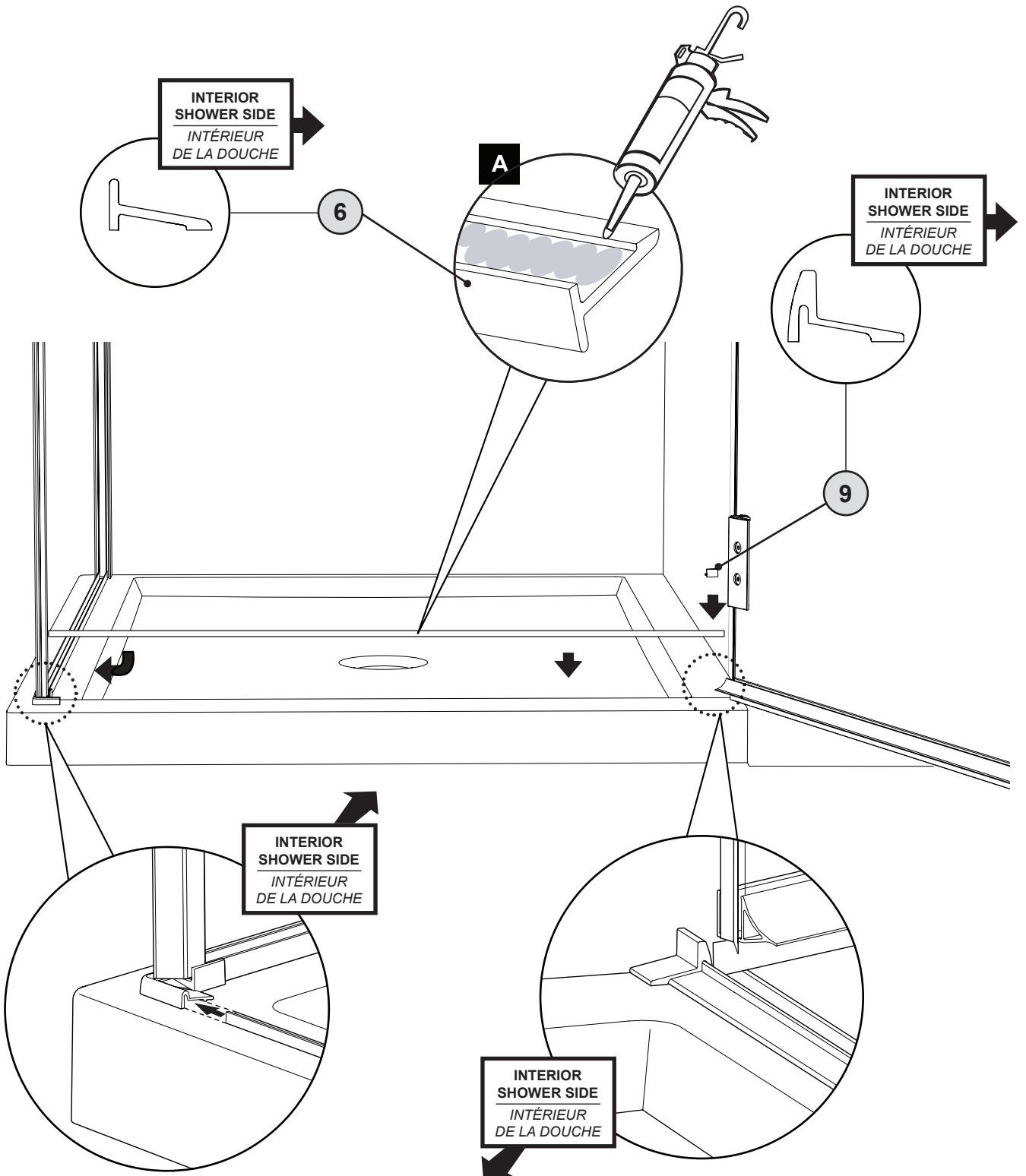



ONLY SEAL THE OUTSIDE OF THE UNIT. DO NOT APPLY SILICONE TO THE INSIDE OF THE SHOWER.
SCELLER SEULEMENT L'EXTÉRIEURE DE LA DOUCHE. NE PAS APPLIQUER LA SILICONE À L'INTÉRIEUR DE LA DOUCHE.

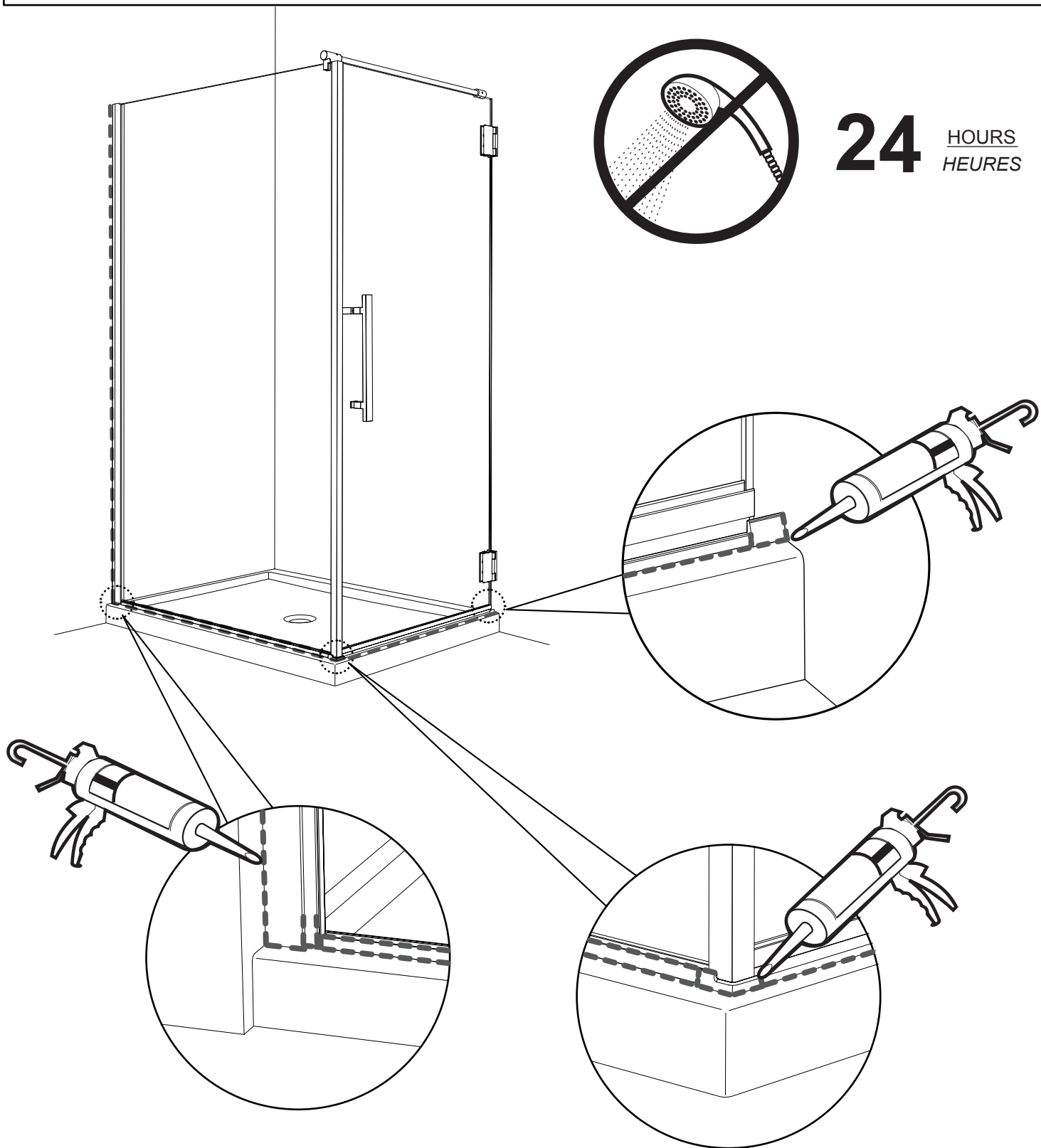

24 HOURS
HEURES