

**INSTRUCTION MANUAL - GUIDE D'INSTALLATION**

**N305**

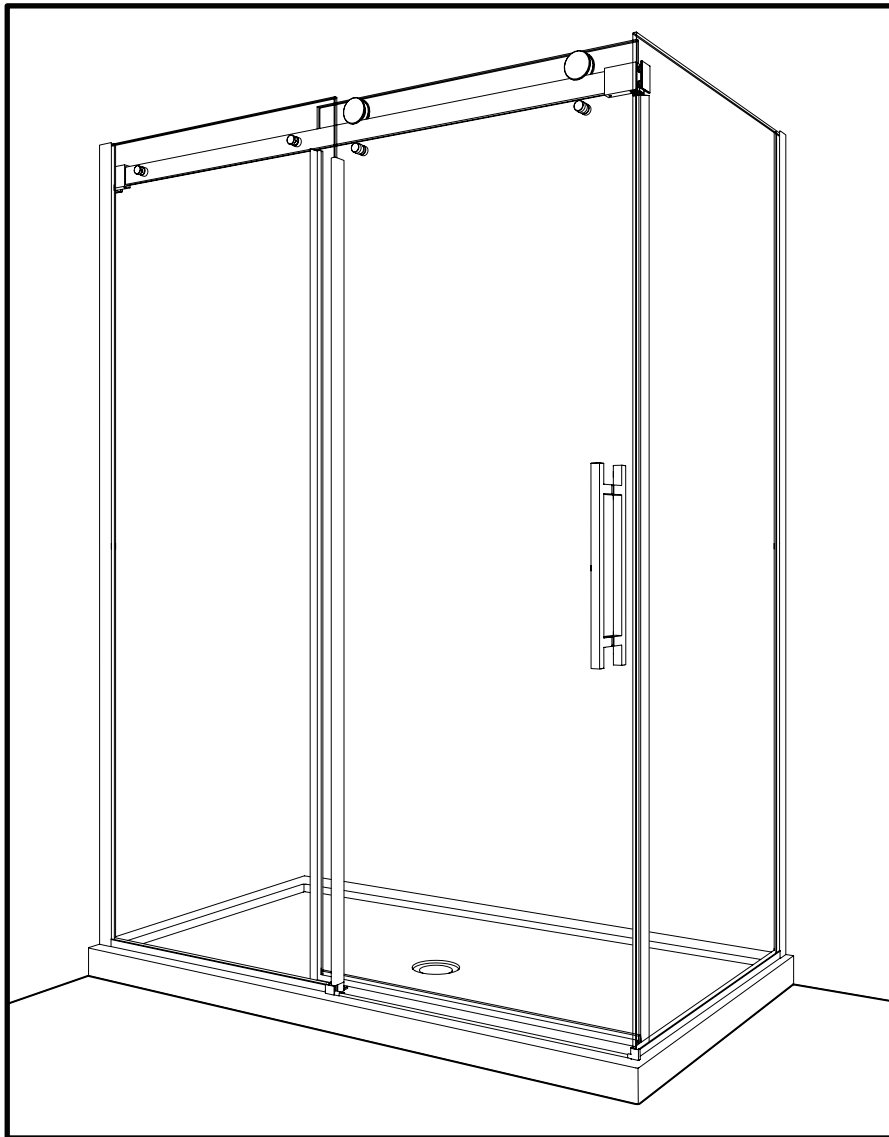

12 / 2019



**2 PEOPLE REQUIRED**  
*2 PERSONNES REQUISES*

Please keep this manual and product code number for future reference and for ordering replacement parts if necessary.

*Veillez conserver ce manuel et le code de produit pour des références futures, et au besoin, la commande de pièces de rechange.*

#### GENERAL INSTRUCTIONS

- Read this manual carefully and completely before proceeding.
- It is recommended that you wear safety glasses at all times during the installation.

#### INSTALLATION OVER CERAMIC TILES

- If your shower door is to be installed over ceramic tiles, the tiles should lay completely under the wall jamb.
- Silicone should be used to seal the gap where the ceramic tiles meet the fixed panel.

#### NOTICE

- Caulking: no sealant is required inside the shower, unless otherwise stated.
- Some models are equipped with clear sealing gaskets.

#### CARE FOR YOUR SHOWER DOOR

- Never use scouring powder pads or sharp instruments on metal pieces or glass panels. An occasional wiping down with a mild soap diluted in water is all that is needed to keep the panels and aluminum parts looking new.
- We recommend wiping the glass panels with a squeegee after each use.

En

#### INSTRUCTIONS GÉNÉRALES

- Lire attentivement et complètement le manuel d'installation avant de procéder.
- Il est recommandé de porter des lunettes de sécurité en tout temps lors de l'installation.

#### INSTALLATION SUR LES TUILES EN CÉRAMIQUE

- Si votre porte de douche doit être installée sur une bordure en céramique, le jambage doit reposer complètement sur cette dernière.
- Le calfeutrage doit être appliqué sur le côté extérieur de la douche où le panneau fixe rencontre la bordure en céramique.

#### NOTE

- Calfeutrage: aucun scellant n'est nécessaire à l'intérieur de la douche.
- Certains modèles sont dotés de joints d'étanchéité clairs.

#### L'ENTRETIEN DE VOTRE DOUCHE

- Ne jamais utiliser de poudre ou de tampon à récurer, ni d'instrument tranchant sur les parties en métal ou en verre. De temps à autre, il suffit de nettoyer la porte avec une solution d'eau et un détergent doux pour conserver l'aspect neuf des panneaux de verre et du cadre en aluminium.
- Nous recommandons de passer une raclette de douche sur les panneaux de verre après chaque utilisation.

Fr

## TOOLS REQUIRED / OUTILS REQUIS

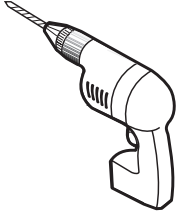

**DRILL**  
PERCEUSE

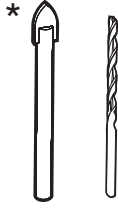

**1/4" & 1/8" DRILL BITS**  
MÈCHE 1/4" & 1/8"



**SCREWDRIVER**  
TOURNEVIS

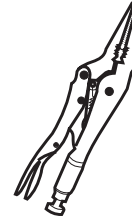

**LONG NOSE LOCKING PLIERS (X2)**  
PINCE SERRE ÉTAU (X2)

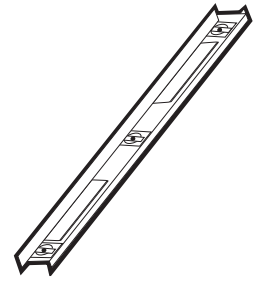

**LEVEL**  
NIVEAU



**PENCIL**  
CRAYON



**TAPE MEASURE**  
RUBAN À MESURER

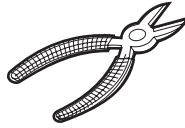

**CUTTING PLIERS**  
PINCE COUPANTE



**MALLET**  
MAILLET



**BLOCK**  
BLOC

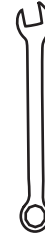

**WRENCH**  
CLÉ À FOURCHE

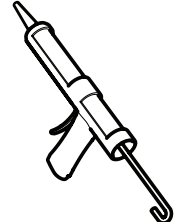

**SILICONE**  
SCCELLANT

\* Use a 1/4" drill bit when drilling into ceramic tiles

\* Utiliser une mèche de 1/4" pour percer des tuiles en céramique.

## POSSIBLE CONFIGURATIONS / CONFIGURATIONS POSSIBLES

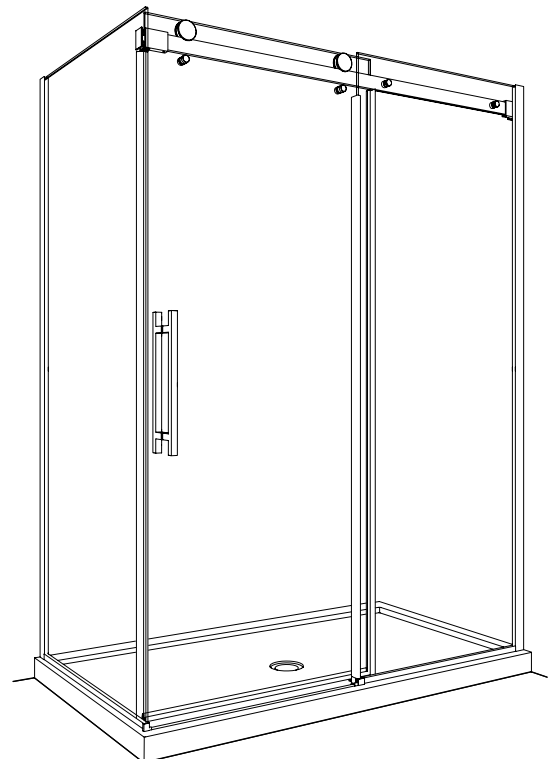
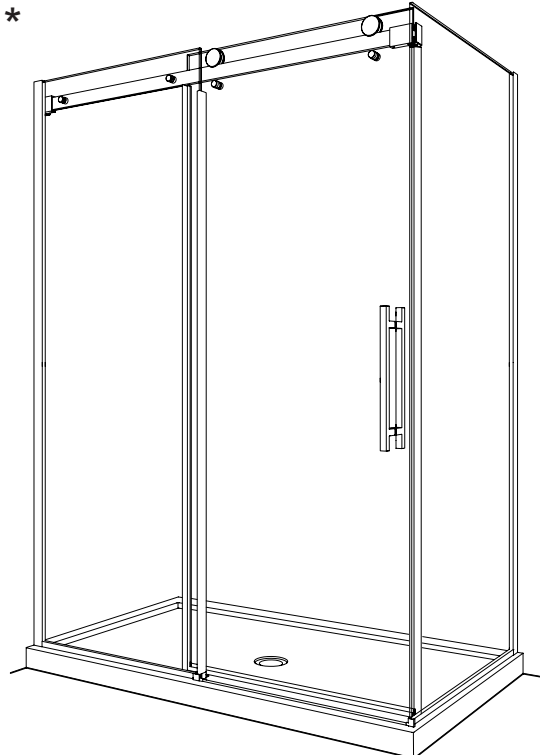

\* This configuration illustrated in this manual.

\* Cette configuration est illustrée dans ce manuel.

PARTS LISTING / LISTE DES PIÈCES

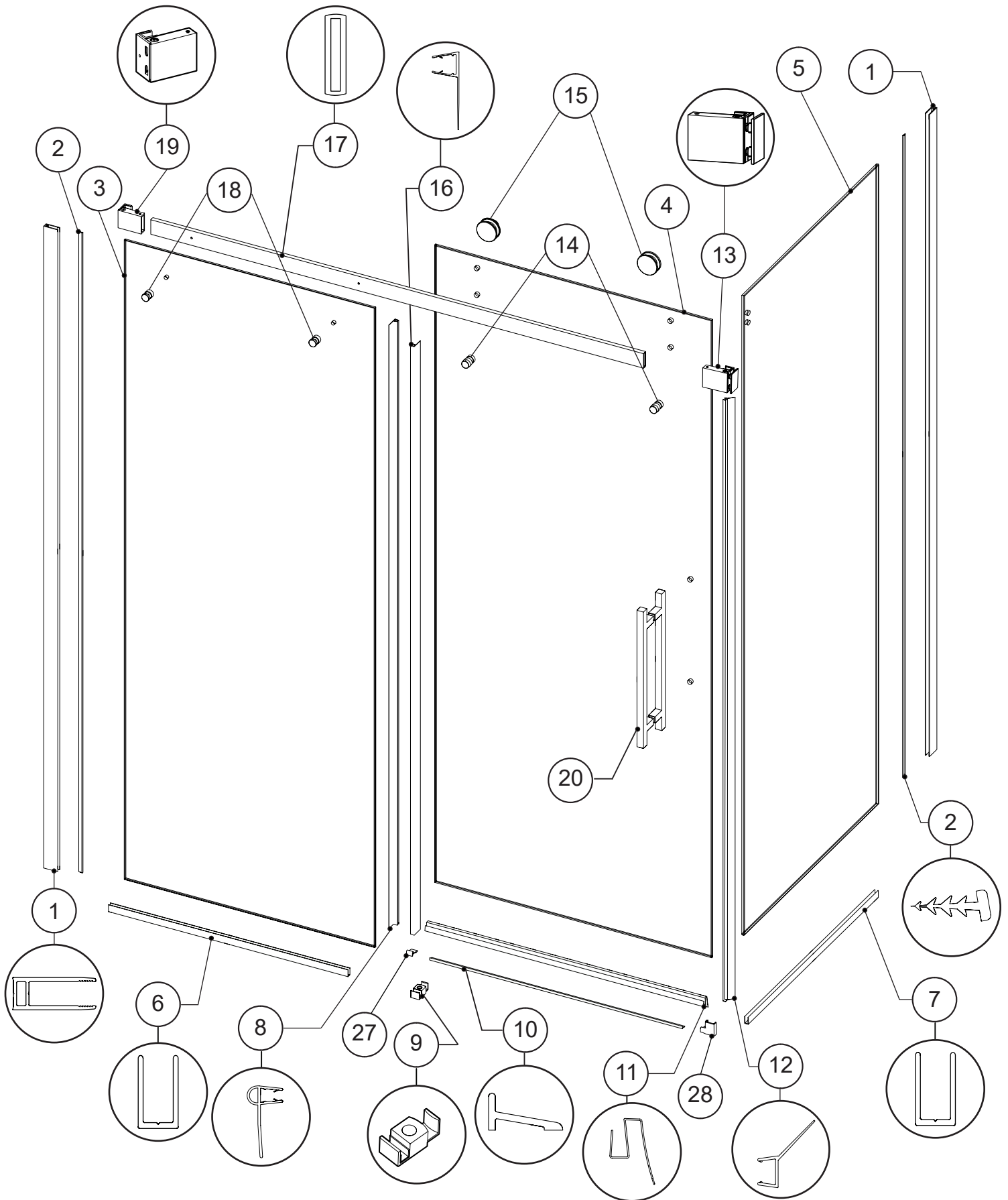

\* Some parts included in the box are not for this configuration.

*Certaines pièces incluses dans la boîte ne sont pas nécessaires pour cette configuration.*

## PARTS LISTING / LISTE DES PIÈCES



21

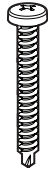

22



23



24

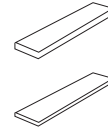

25



26

ITEM	FLEURCO CODE	PARTS LISTING / LISTE DES PIÈCES	QTY
1	NXV-WJAMB-79-XX	WALL JAMB / JAMBAGE	2
2	VINYL-NH/S-86	WALL JAMB GASKET / JOINT DU JAMBAGE	2
3		FIXED PANEL / PANNEAU FIXE	1
4		DOOR PANEL / PANNEAU DE PORTE	1
5		RETURN PANEL / PANNEAU DE RETOUR	1
6	NP/NXV-UCHANNEL-42-XX	U-CHANNEL FOR FIXED PANEL / PROFILÉ EN «U» POUR PANNEAU FIXE	1
7	NP/NXV-UCHANNEL-42-XX	U-CHANNEL FOR RETURN PANEL / PROFILÉ EN «U» POUR PANNEAU DE RETOUR	1
8	COEX N305-75	MID GASKET FOR DOOR PANEL / JOINT LATÉRAL POUR LE PANNEAU DE PORTE	1
9	NXV-BTMGUIDE-XX	BOTTOM DOOR GASKET / JOINT INFÉRIEUR DE PORTE	1
10	PLAT-THRESH-XX-72 ++15405	ALUMINUM THRESHOLD / SEUIL DE RÉTENTION	1
11	COEX K-130-72	BOTTOM DOOR GASKET / JOINT INFÉRIEUR DE PORTE	1
12	COEX-N430-75	DOOR CLOSING GASKET / JOINT FERMETURE DE PORTE	1
13	NXV-WMBRACKET-XX + NOV2FACEPLATE-XX	RETURN PANEL GLASS MOUNT BRACKET / SUPPORT DE VERRE POUR PANNEAU DE RETOUR	1
14	NXV-ANTIJUMP-XX	ANTI-JUMP / ANTI-SAUT	2
15	NXV-ROLLER-XX	ROLLER / ROULETTE	2
16	COEX-N310-80	MID GASKET FOR FIXED PANEL / JOINT LATÉRAL POUR PANNEAU FIXE	1
17	NXV-BAR-**-XX	RUNNING RAIL / BARRE DE ROULEMENT	1
18	NOVFASTENER-XX	GLASS FASTENER / FIXATION DE VERRE	2
19	NXV-WMBRACKET-XX	FIXED PANEL WALL MOUNT BRACKET / SUPPORT MURAL POUR PANNEAU FIXE	1
20	NOVHANDLE-XX	DOOR HANDLE / POIGNÉE DE PORTE	1
ITEM		HARDWARE LISTING / LISTE DE QUINCAILLERIE	QTY
21		WALL PLUG / CHEVILLE	6
22		PAN SELF-DRILLING SCREW / VIS PAN AUTO PERÇANTE	7
23		SCREW / VIS	2
24		KEY / CLÉ	1
25		CLEAR SETTING BLOCK (2 X 1/16" & 2 X 1/8" ) / BLOC À NIVEAU TRANSPARENT (2 X 1/16" & 2 X 1/8")	8
26		HEX KEY 3MM / CLÉ HEXAGONALE 3MM	1
27	PENDCAP-XX	THRESHOLD ANCHOR / L'ANCRAGE DE SEUIL	1
28	UTELBOW-XX	CORNER THRESHOLD / ANCRAGE DU SEUIL DE COIN	1 SET

**LEGEND / LÉGENDE**

XX = FINISH/FINI (11, 25, 33)

\*\* = LENGTH / LONGUEUR (54, 60, 79, 86 ETC)

++ = CODE / CODE (AC, ABN)

**1**

**MARK THE RETURN PANEL PLACEMENT AREA ON THE BASE**  
**MARQUER LA ZONE DE POSITIONNEMENT DU PANNEAU DE RETOUR SUR LA BASE**

SIZE TAILLE	From wall to center of return panel <i>Mur fini au centre du panneau de retour</i>	
	MIN	MAX
48	45 1/2"	48"
60	56"	60"

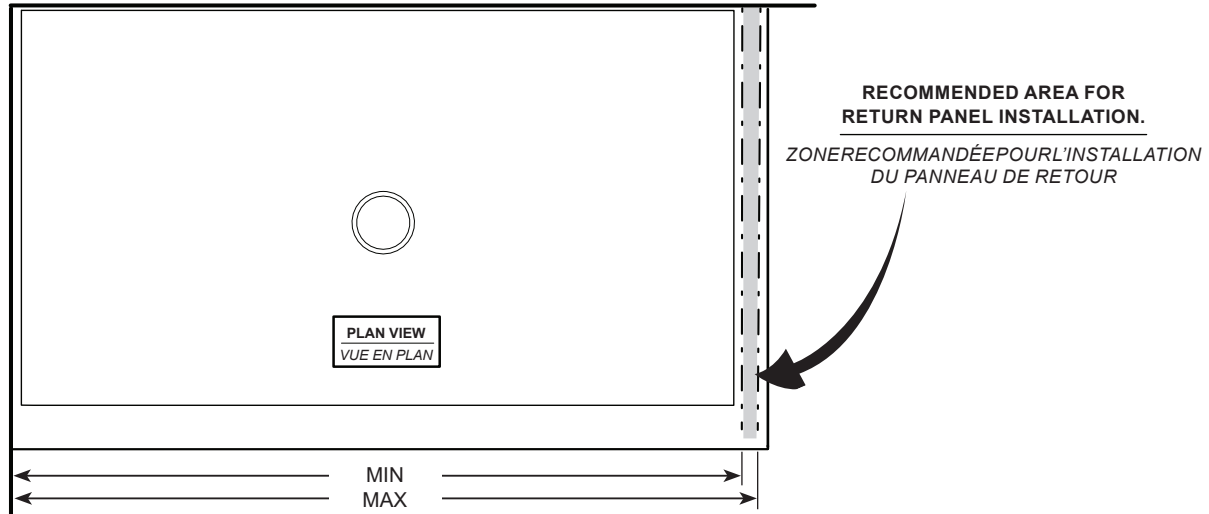
**2**

**MARK THE PLACEMENT LINE FOR THE RETURN PANEL ON THE BASE WITHIN THE PLACEMENT AREA**  
**MARQUER LA LIGNE DE POSITIONNEMENT POUR LE PANNEAU DE RETOUR SUR LA BASE DANS LA ZONE DE POSITIONNEMENT**

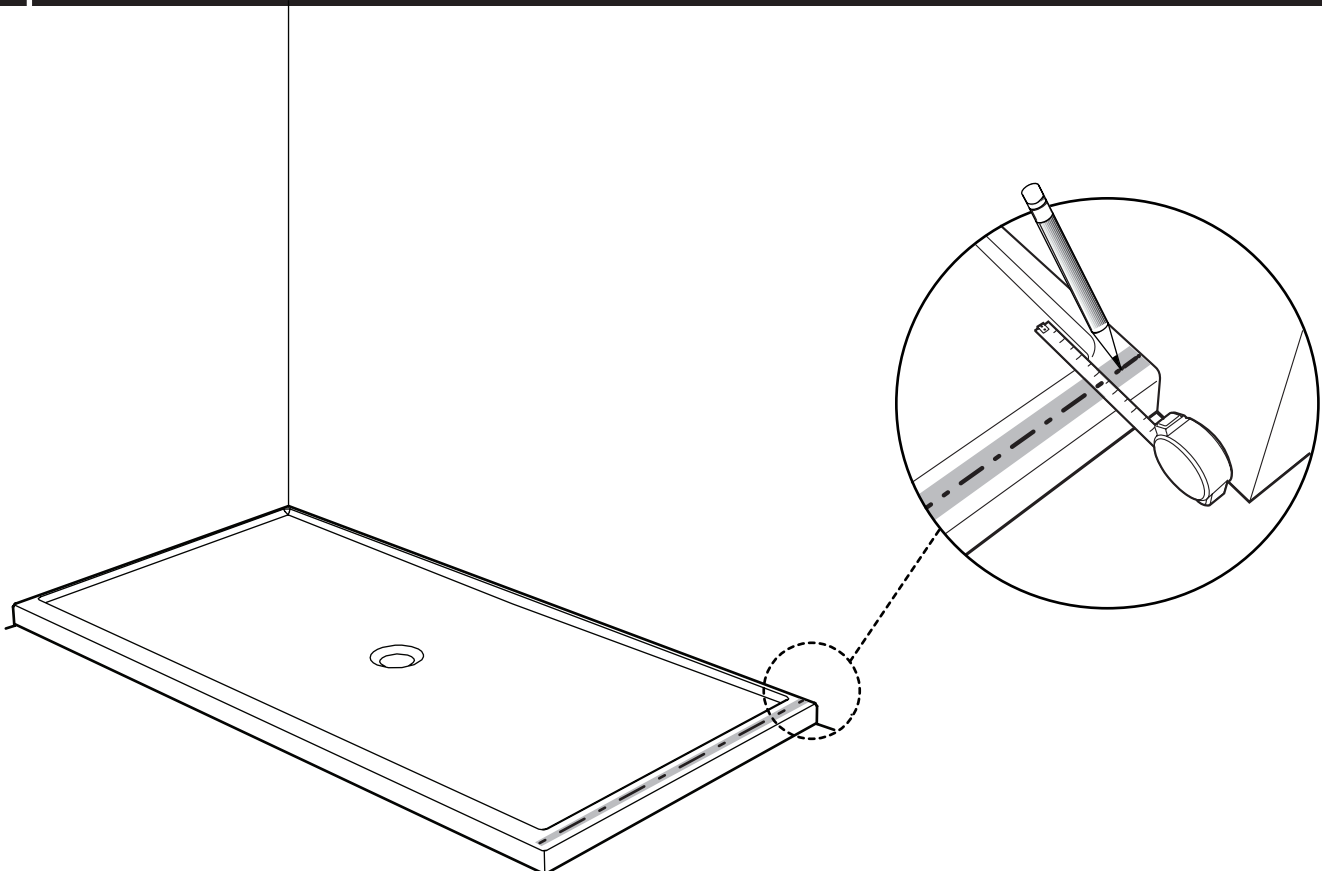

3

CENTER THE WALL JAMB / CENTRER LE JAMBAGE

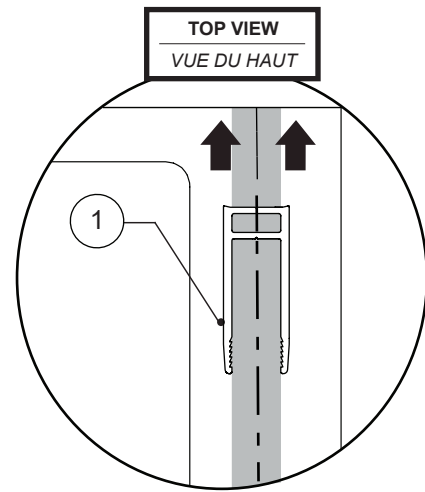
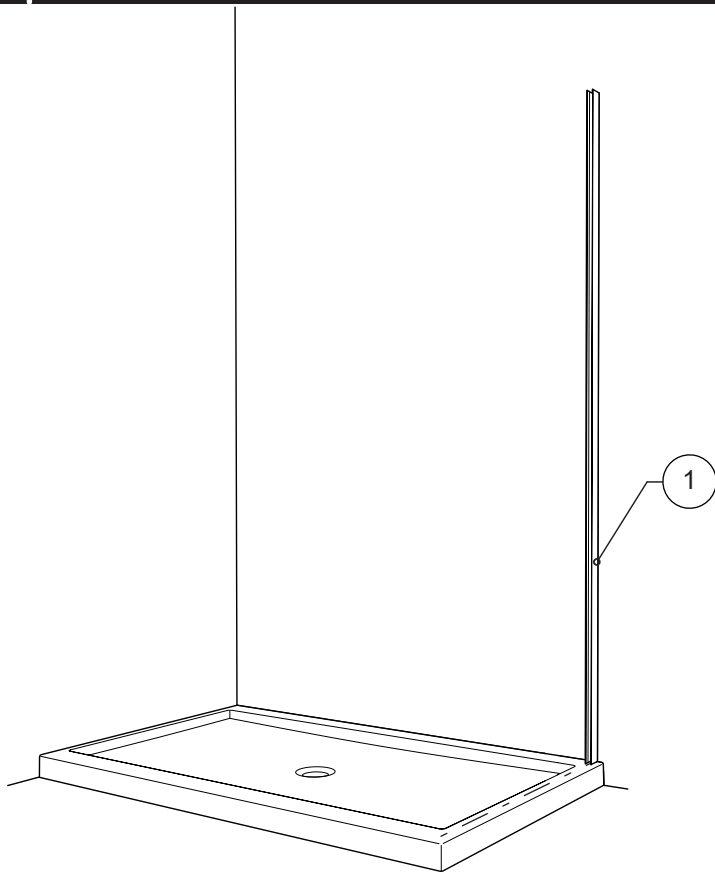

4

MARK THE LOCATION OF THE WALL JAMB HOLES ON THE WALL  
MARQUER L'EMPLACEMENT DES TROUS DU JAMBAGE SUR LE MUR

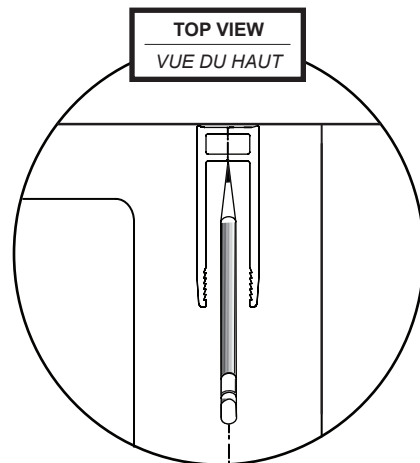
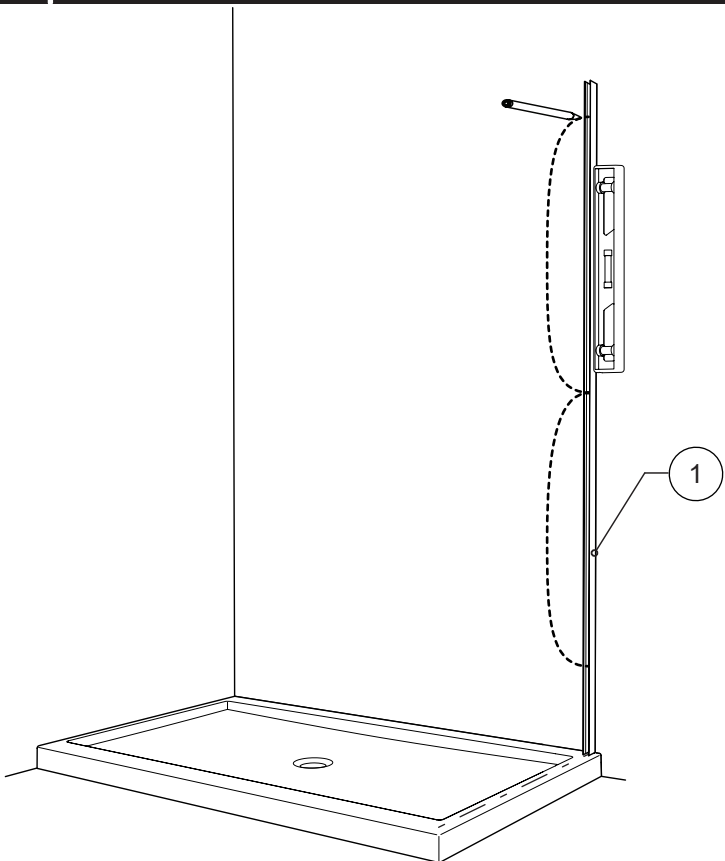

5

**DRILL, APPLY SILICONE & INSERT THE WALL PLUGS**  
*PERCER, APPLIQUER DU SILICONE ET INSÉRER LES CHEVILLES*

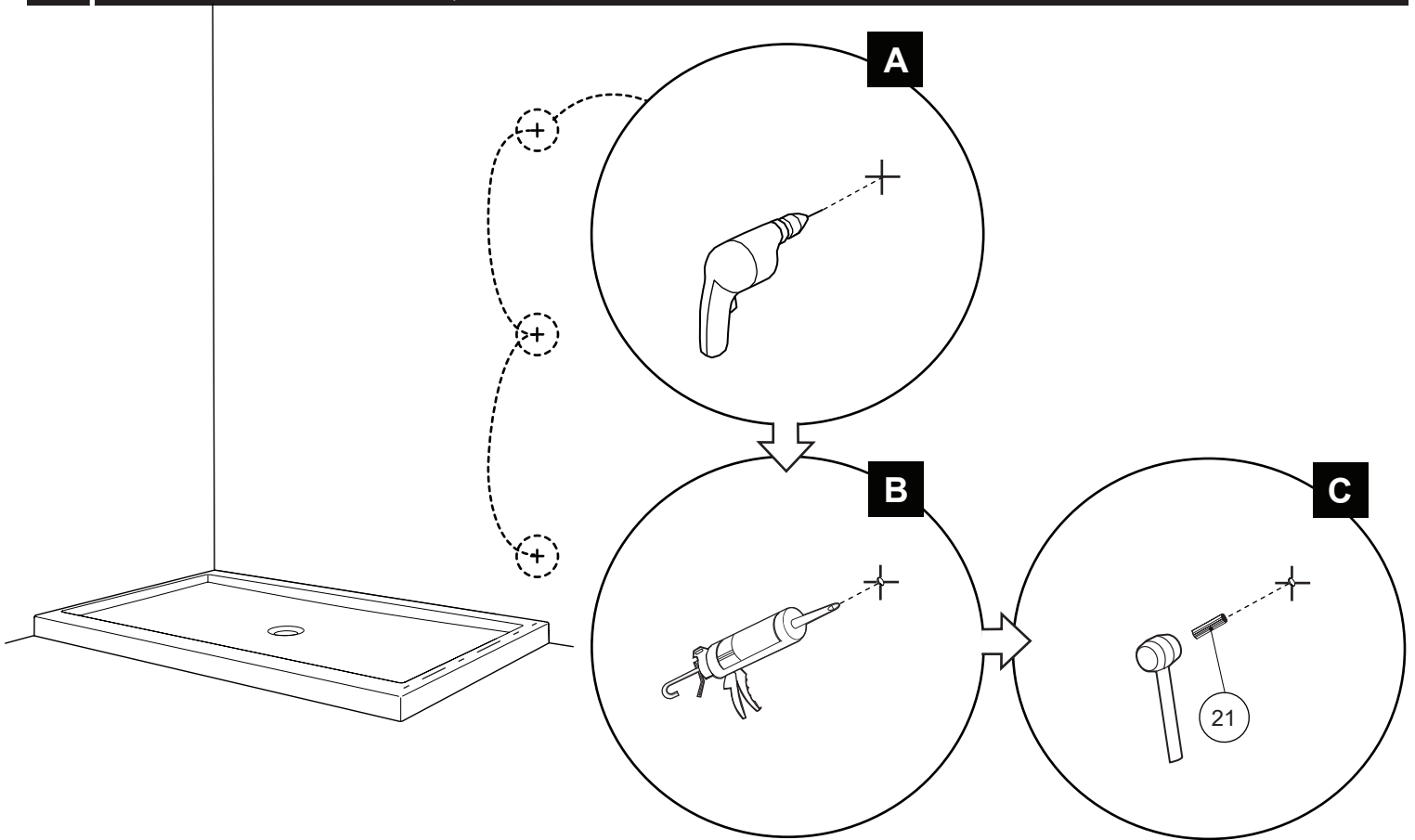

6

**SILICONE AND SECURE THE WALL JAMB / CALFEUTRER ET SÉCURISER LE JAMBAGE**

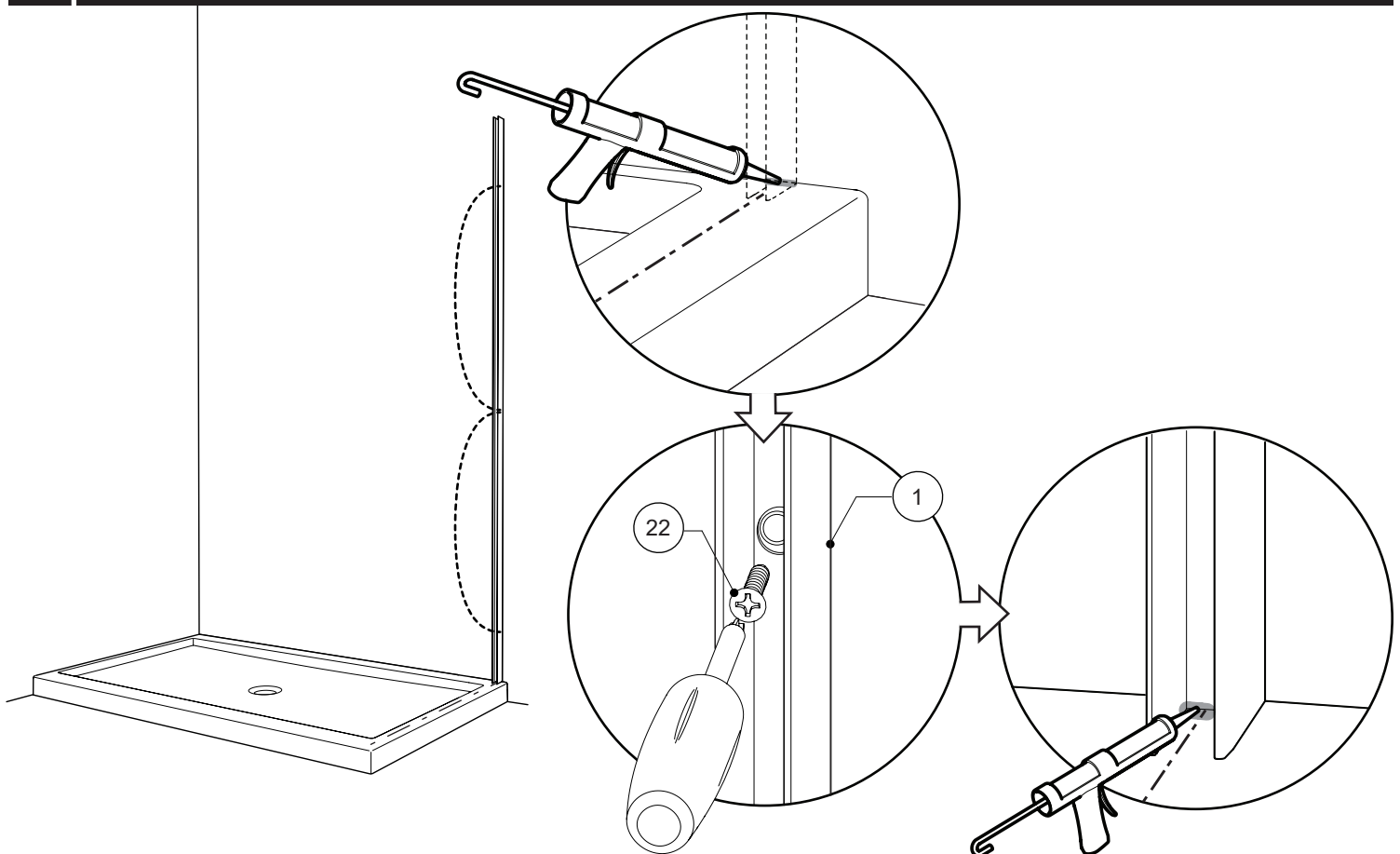



7

**MARK THE FIXED PANEL PLACEMENT AREA ON THE BASE**  
**MARQUER LA ZONE DE POSITIONNEMENT DU PANNEAU FIXE SUR LA BASE**

SIZE TAILLE	Fixed panel placement Placement du panneau fixe	
	MIN	MAX
32	29 3/8"	29 7/8"
36	33 3/8"	33 7/8"

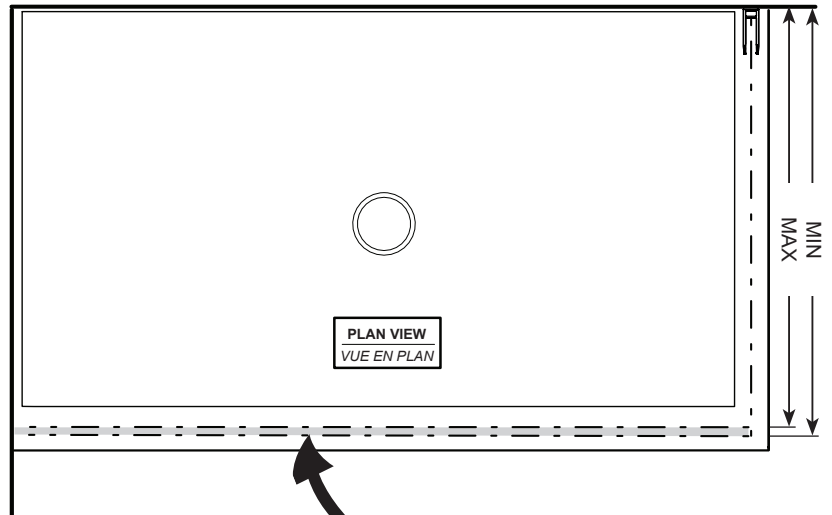

**RECOMMENDED AREA FOR  
FIXED PANEL INSTALLATION.**

**ZONERECOMMANDÉEPOURL'INSTALLATION  
DU PANNEAU FIXE .**

8

**DETERMINE THE CENTERLINE FOR FIXED PANEL LOCATION USING THE BOTTOM GUIDE FOR REFERENCE**  
**MARQUER LA LIGNE DU CENTRE DU PANNEAU FIXE SUR LA BASE EN UTILISANT LE GUIDE INFÉRIEUR COMME RÉFÉRENCE**

**Suggested installation for better performance.**

*Installation suggérée pour une meilleure performance.*

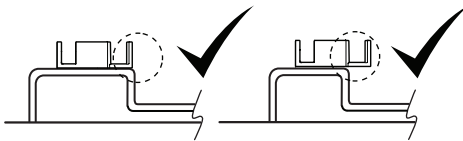

**SIDE VIEW / VUE LATÉRALE**

**The bottom guide can hang off the base as long as it can be well fastened and is towards the inside of the shower.**

*Le guide inférieur peut dépasser la base en autant qu'il puisse être bien fixé et vers l'intérieur de la douche.*

**Edge of base threshold  
(inside shower side)**

*Côté intérieur de la douche  
(Bord du seuil de base)*



**Do not install the bottom guide (9) in this step.**

*Ne pas installer le guide inférieur (9) dans cette étape.*

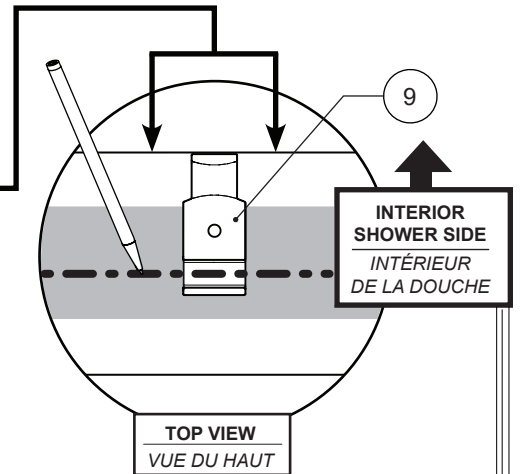

THE POSITIONING OF THE BOTTOM GUIDE IS CARRIED OUT ON **FLEURCO** BASES. FOR **NON-FLEURCO** BASES REFER TO THE CHARTS ON PAGE 6 TO PROPERLY PLACE THE BOTTOM GUIDE.

**LE PLACEMENT DU GUIDE DE BAS EST EFFECTUÉ SUR DES BASES FLEURCO, POUR LE POSITIONNEMENT DU GUIDE DE BAS SUR DES BASES N'APPARTENANT PAS À FLEURCO, SE RÉFÉRER AUX TABLAUX SUR LA PAGE 6**

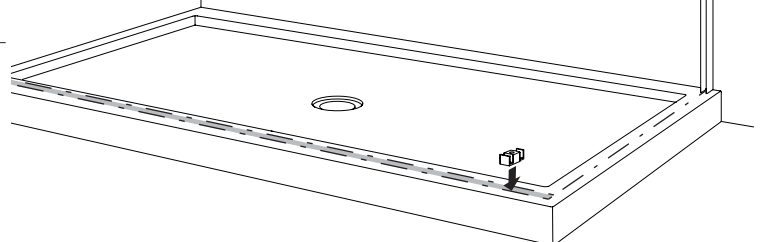

9

**DETERMINE THE CENTER LINE FOR U CHANNEL DIMENSION BY USING THE BOTTOM GUIDE FOR REFERENCE**  
**DÉTERMINER LA LIGN DE CENTRE DU PROFILÉ EN «U» EN UTILISANT LE GUIDE COMME RÉFÉRENCE**

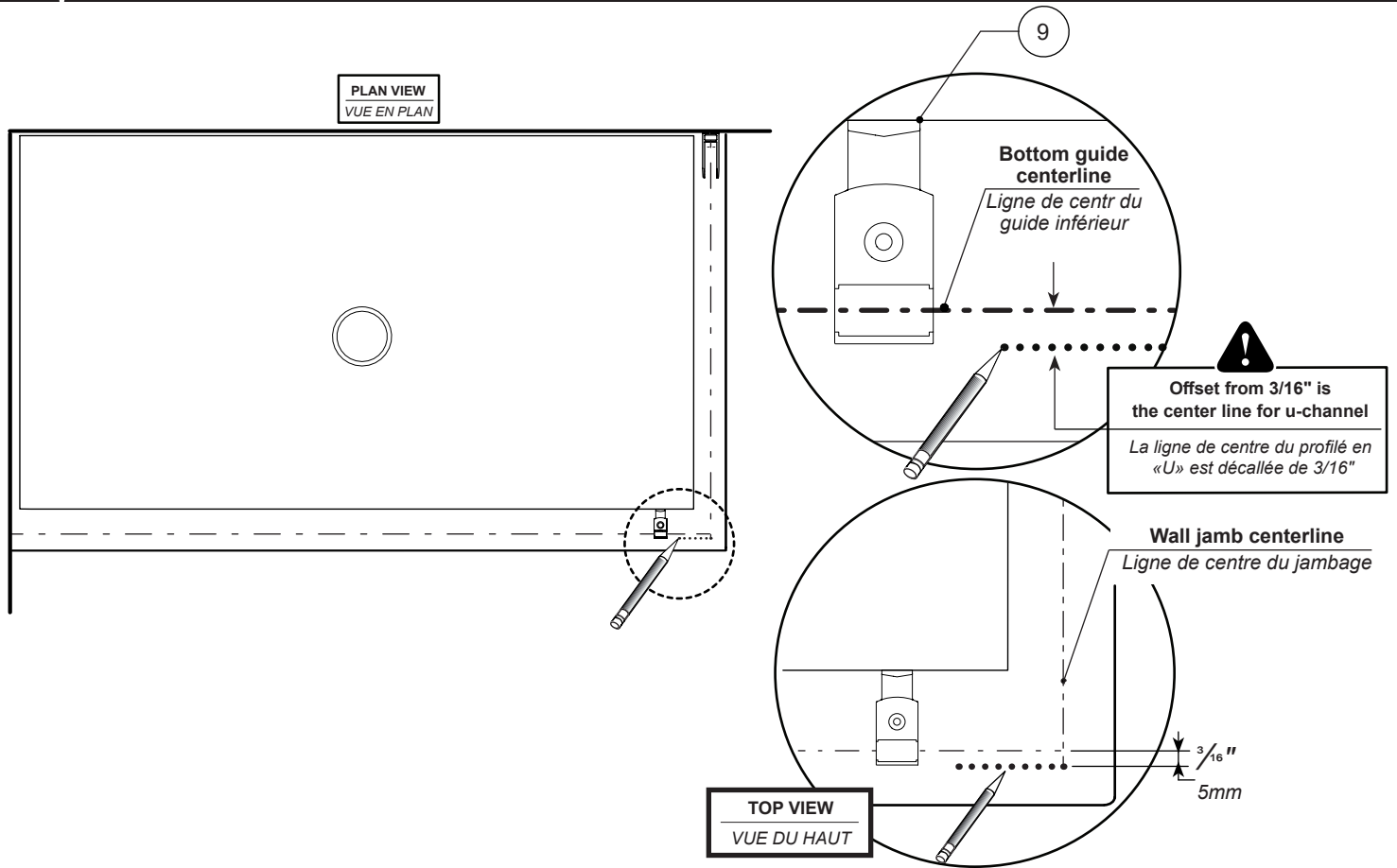

10

**TEMPORARILY PLACE THE U-CHANNEL FOR RETURN PANEL**  
**PLACER LE PROFILÉ EN «U» POUR LE PANNEAU DE RETOUR TEMPORAIREMENT**

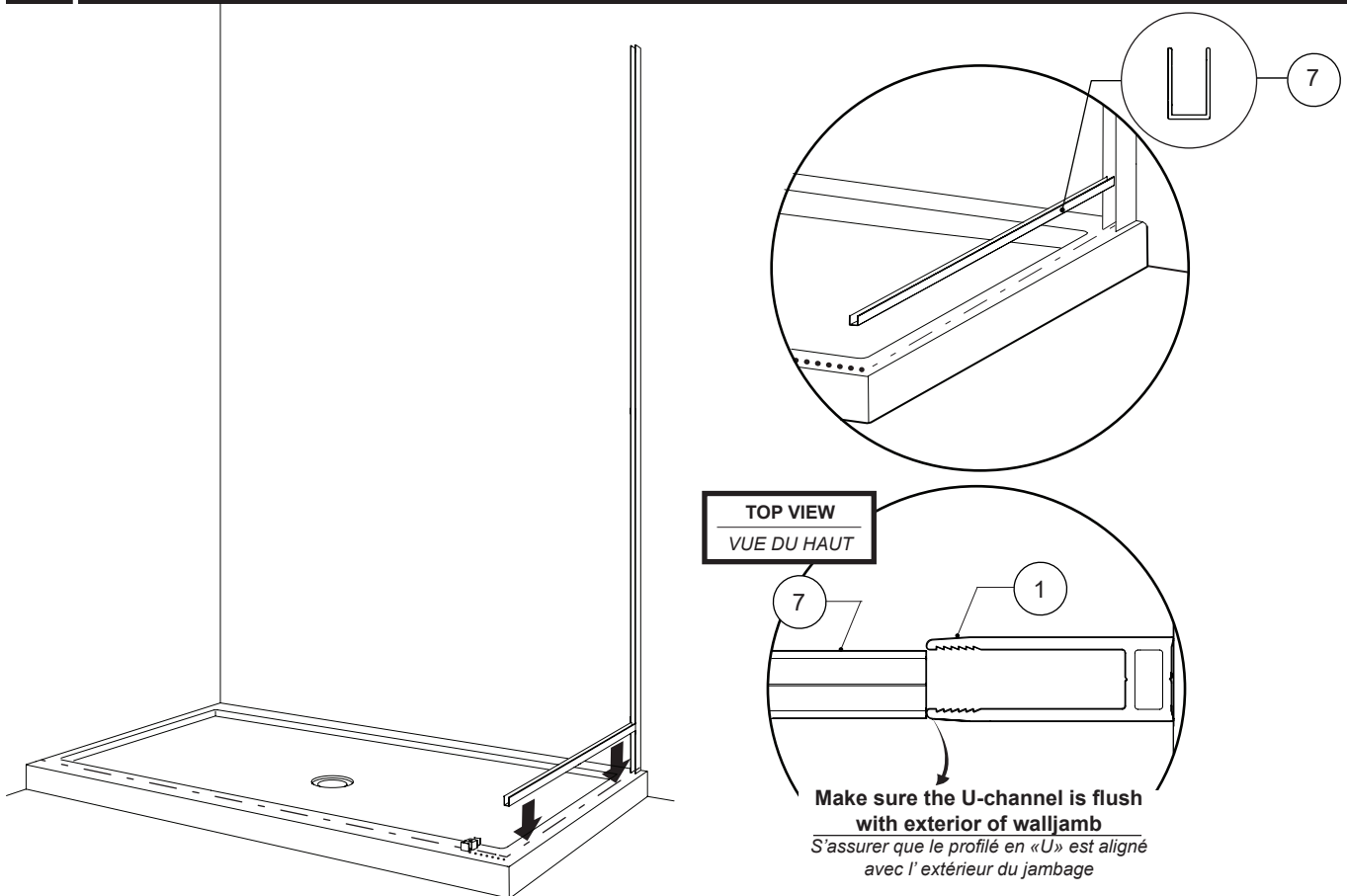

11

**MARK THE U-CHANNEL FOR RETURN PANEL CUT LINE**  
**MARQUER LA LIGNE DE COUPE DU PROFILÉ EN «U» POUR LE PANNEAU DE RETOUR**

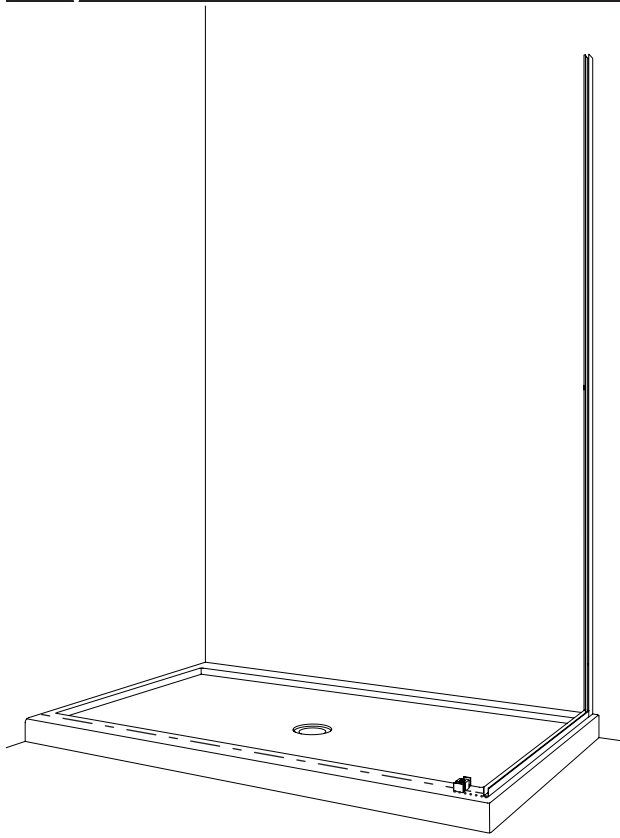

  
**Refrence line for  
cuting the u-channel**  
*Ligne de référence pour  
couper le profilé en «U»*

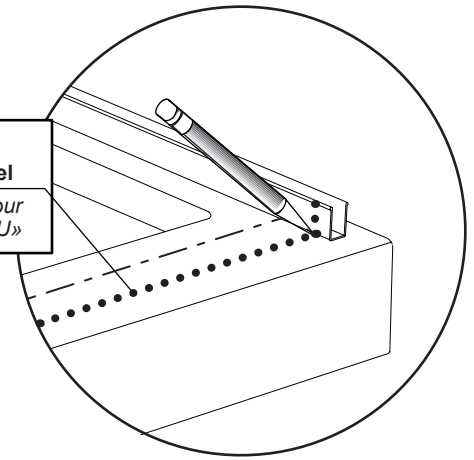

**TOP VIEW**  
**VUE DU HAUT**

$\frac{3}{16}$ "  
5mm

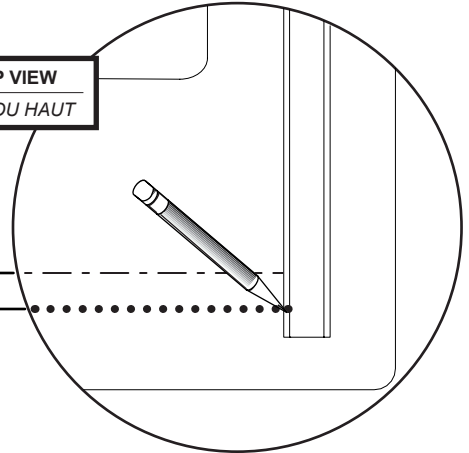

12

**CUT THE U-CHANNEL FOR THE RETURN PANEL**  
**COUPER LE PROFILÉ EN «U» POUR LE PANNEAU DE RETOUR**

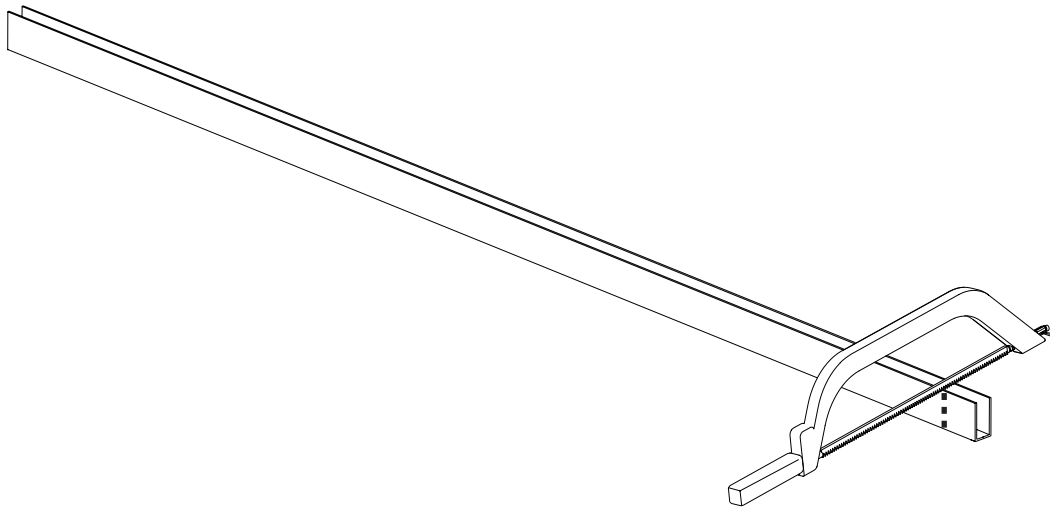

**13**

**INSTALL THE U-CHANNEL FOR RETURN PANEL**  
**INSTALLER LE PROFILÉ EN «U» POUR LE PANNEAU DE RETOUR**

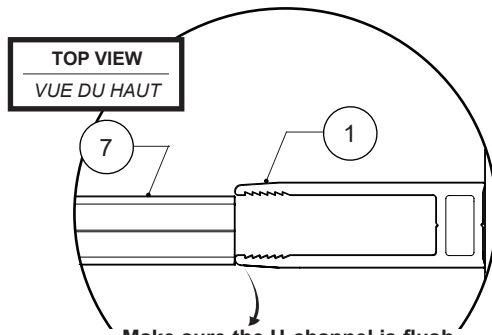
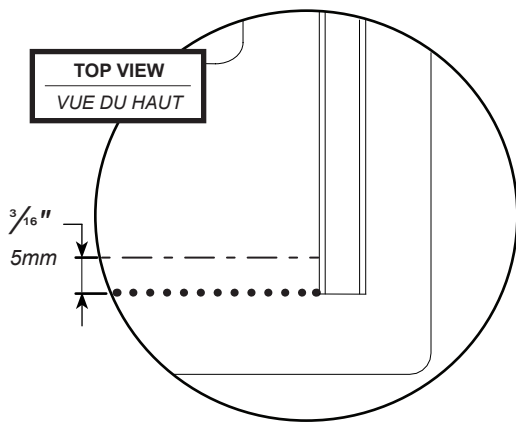

**Make sure the U-channel is flush with exterior of walljamb**  
*S'assurer que le profilé en «U» est aligné avec l'extérieur du jambage*

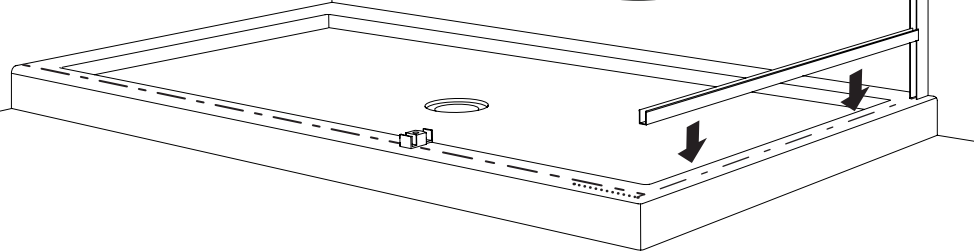
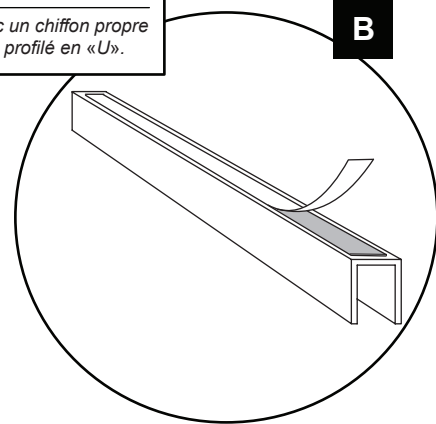
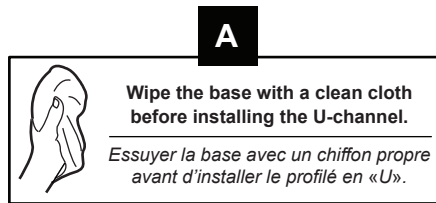
**14**

**INSTALL THE RETURN PANEL AND LEVEL / INSTALLER LE PANNEAU DE RETOUR ET NIVELER**

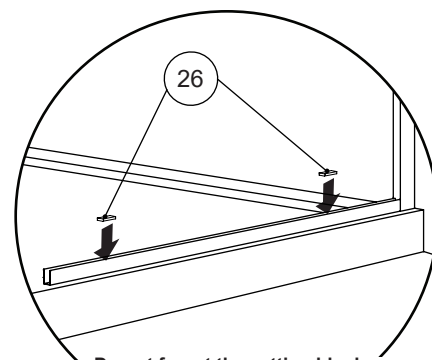
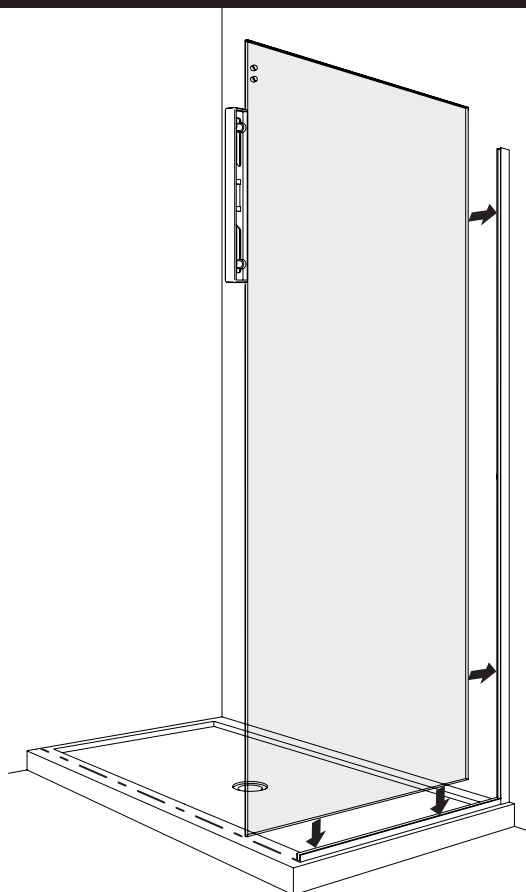

**Do not forget the setting blocks.**  
*Ne pas oublier les blocs de niveau transparents.*

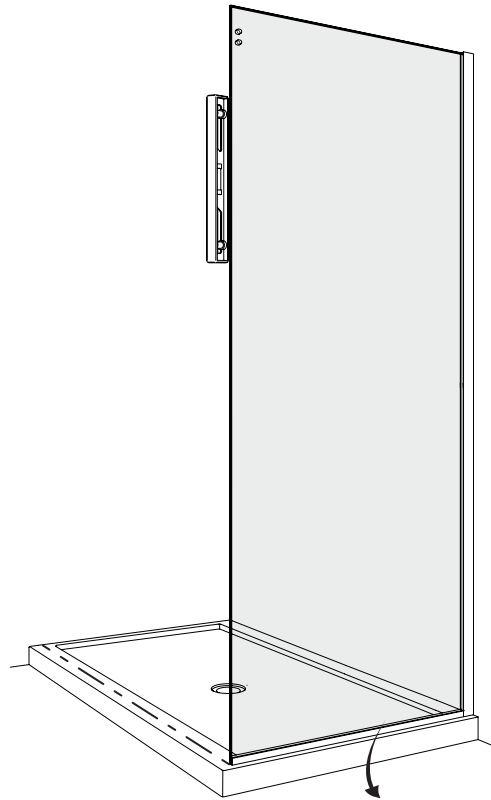

Use additional setting blocks to adjust if necessary.  
 Utiliser des blocs de niveau transparents supplémentaires pour ajuster si nécessaire.

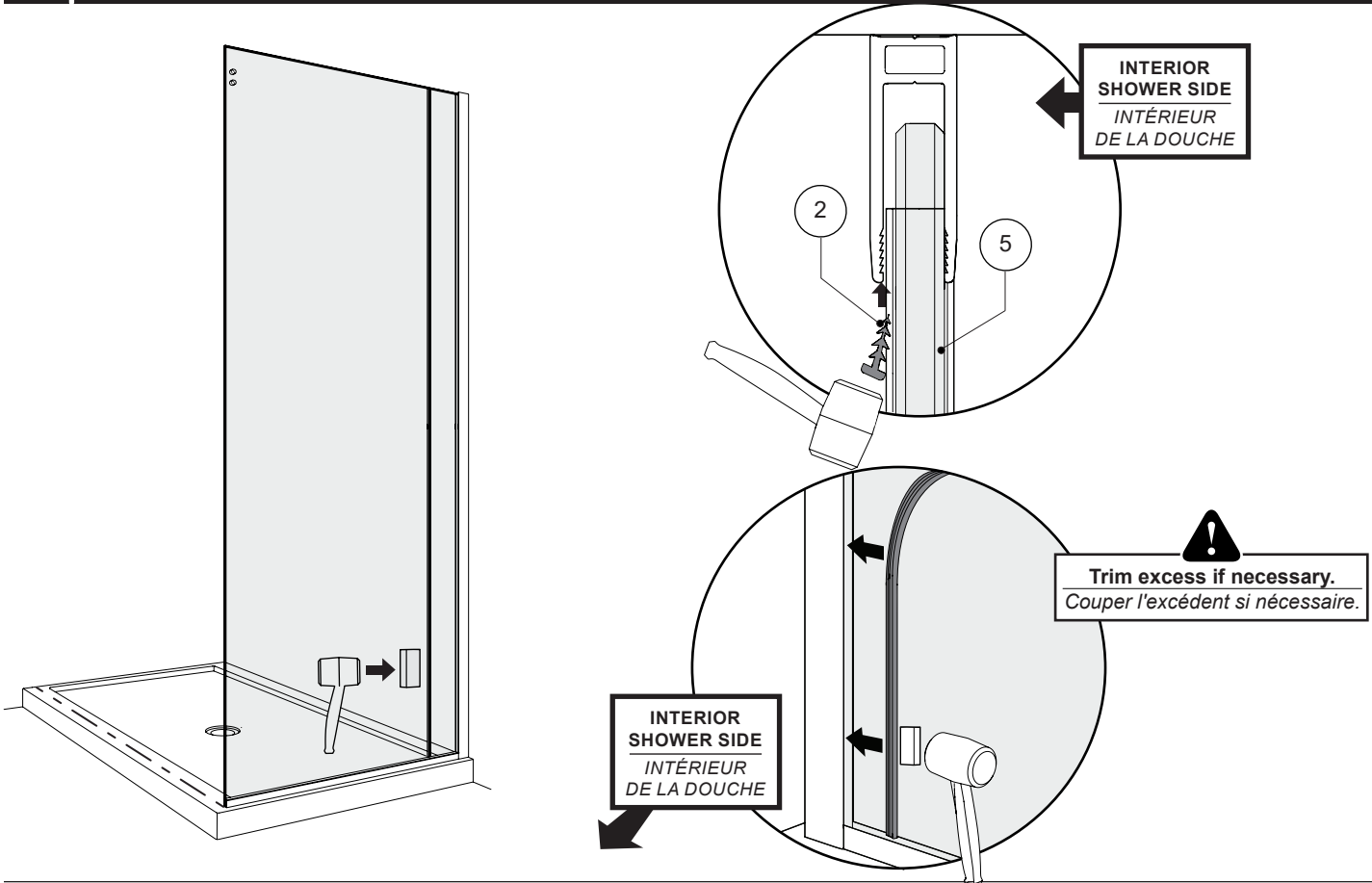

**17** INSTALL THE RETURN PANEL BRACKET / INSTALLER LE SUPPORT DE VERRE POUR PANNEAU DE RETOUR

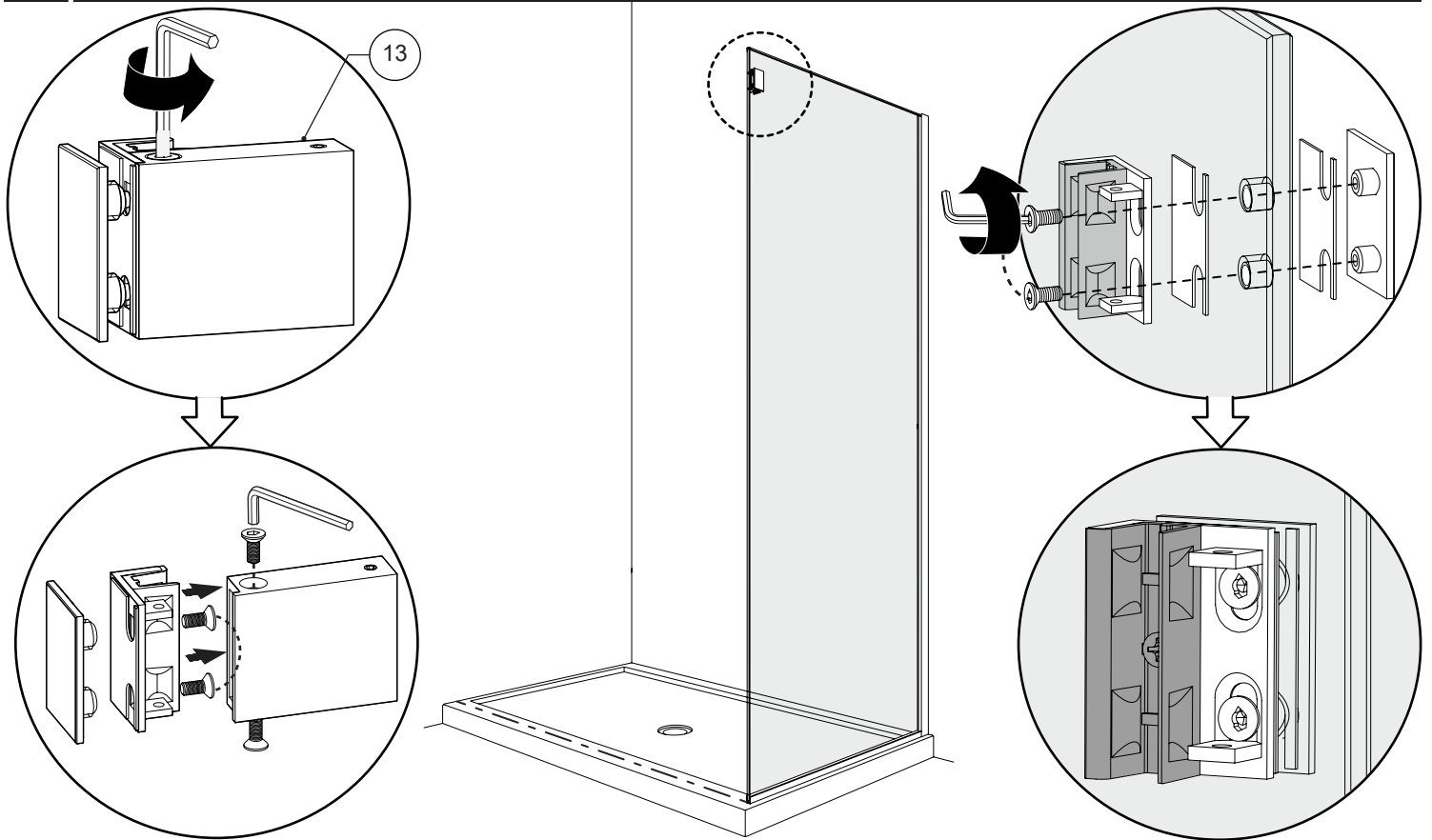

**18** INSTALL THE BOTTOM DOOR GASKET ONTO THE DOOR / INSTALLER LE JOINT INFÉRIEUR DE LA PORTE SUR LE PANNEAU DE PORTE

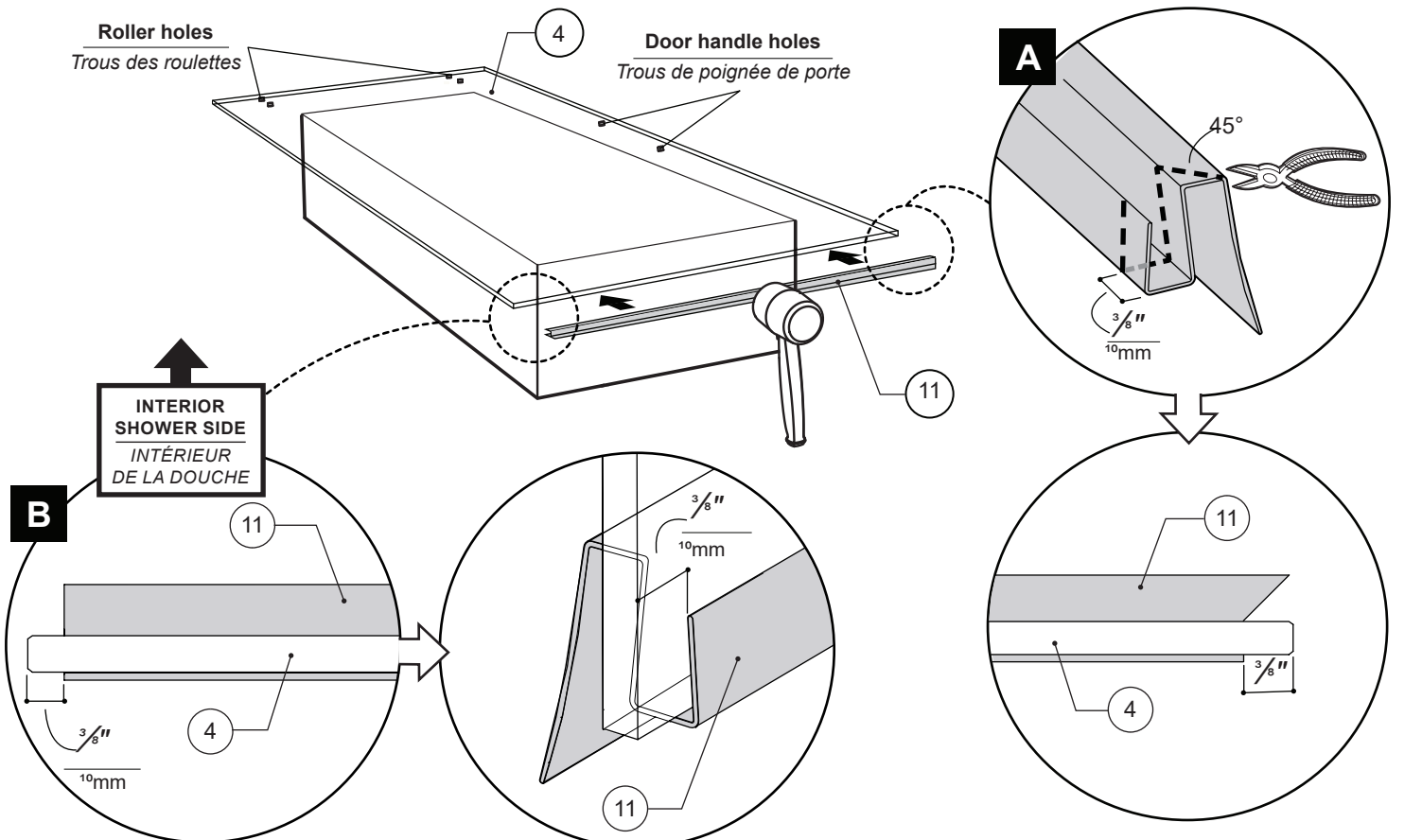

**INSTALL THE ROLLERS ONTO THE DOOR**  
**INSTALLER LES ROULETTES SUR LA PORTE**

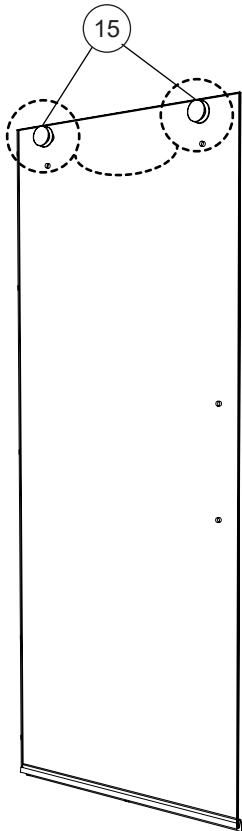

**Do not place the roller cap in this step**  
*Ne pas placer le capuchon des roulettes dans cette étape*

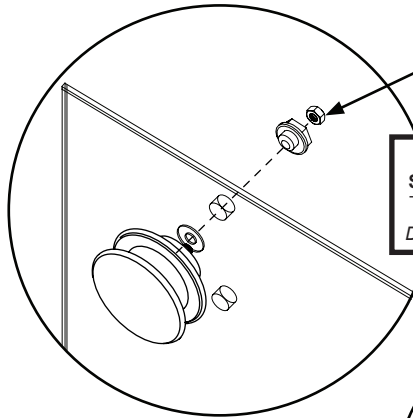

**INTERIOR  
SHOWER SIDE**  
**INTÉRIEUR  
DE LA DOUCHE**

**Hold eccentric nut in place with  
wrench while tightening the small nut.**  
*Tenir l'écrou excentrique en place avec  
la clé tout en serrant le petit écrou .*

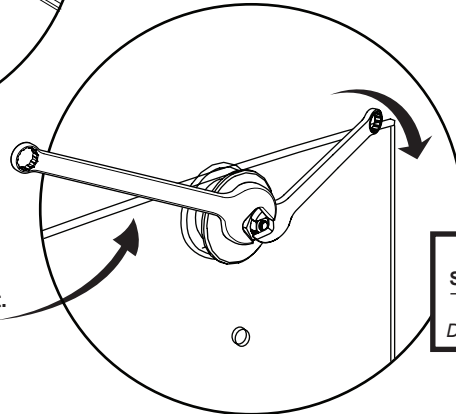

**INTERIOR  
SHOWER SIDE**  
**INTÉRIEUR  
DE LA DOUCHE**

**Eccentric nut for roller adjustment. (Raises and lowers the roller.) Minimum spacing should be oriented towards the bottom as shown. Adjustments can be made after the door installation.**

*Écrou excentrique pour l'ajustement des roulettes. (Lève et baisse la roulette.) L'espace minimum devrait être orienté vers le bas tel qu'illustré. Les ajustements peuvent être effectués après l'installation de la porte.*

**INSTALL THE HANDLE ONTO THE DOOR**  
**INSTALLER LA POIGNÉE SUR LA PORTE**

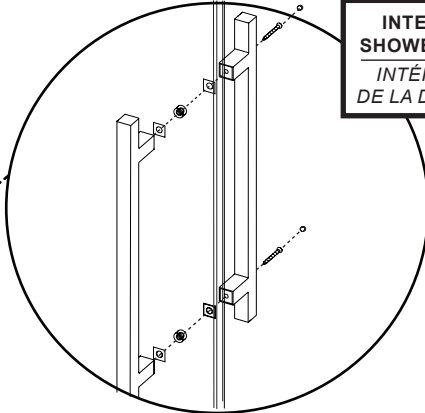
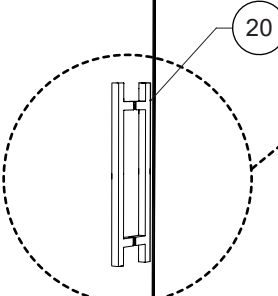
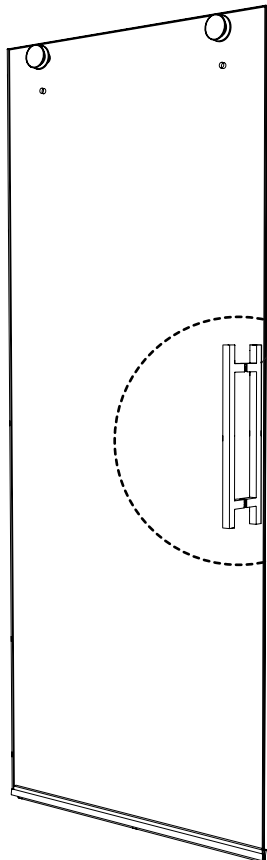

**INTERIOR  
SHOWER SIDE**  
**INTÉRIEUR  
DE LA DOUCHE**

21

**PLACE THE DOOR INSIDE THE SHOWER**  
*PLACER LA PORTE À L'INTÉRIEUR DE LA DOUCHE*

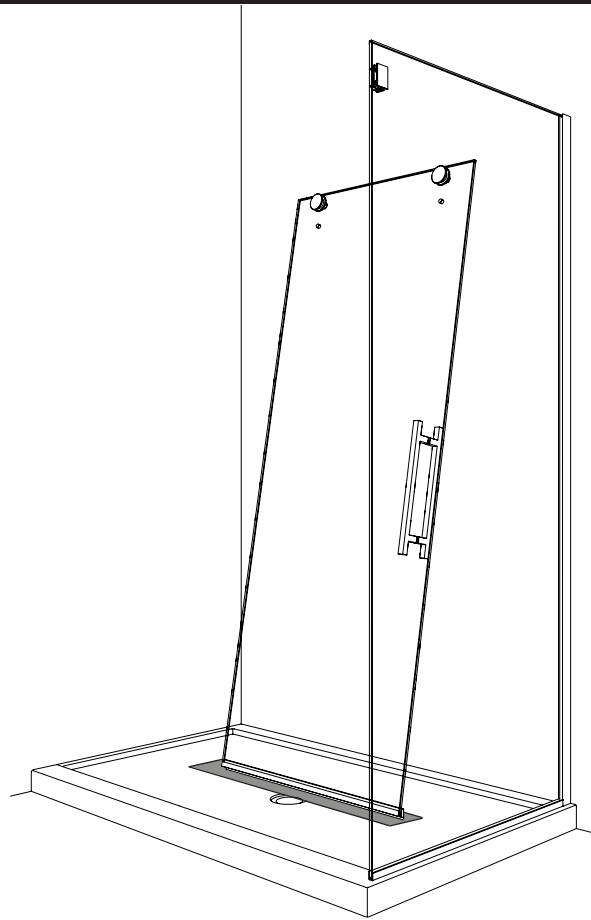

22

**PLACE THE FIXED PANEL WALL JAMB**  
*PLACER LE JAMBAGE DU PANNEAU FIXE*

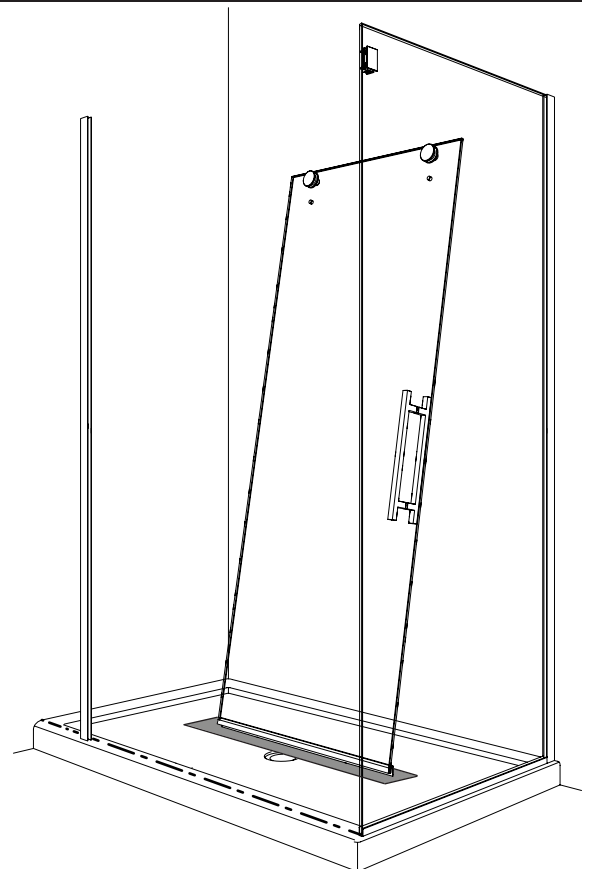
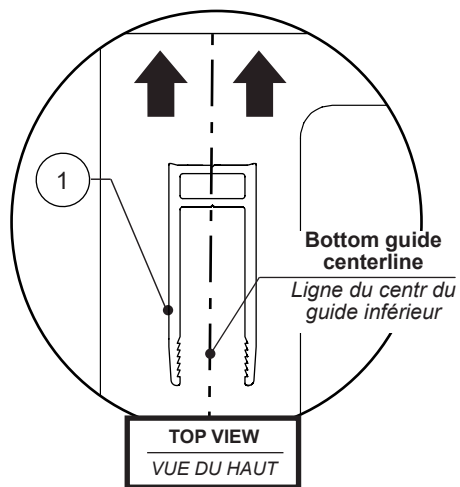



**23** LEVEL AND MARK THE LOCATION OF THE FIXED PANEL WALL JAMB HOLES ON THE WALL  
*NIVELER ET MARQUER L'EMPLACEMENT DES TROUS DU JAMBAGE POUR LE PANNEAU DU FIXE SUR LE MUR*

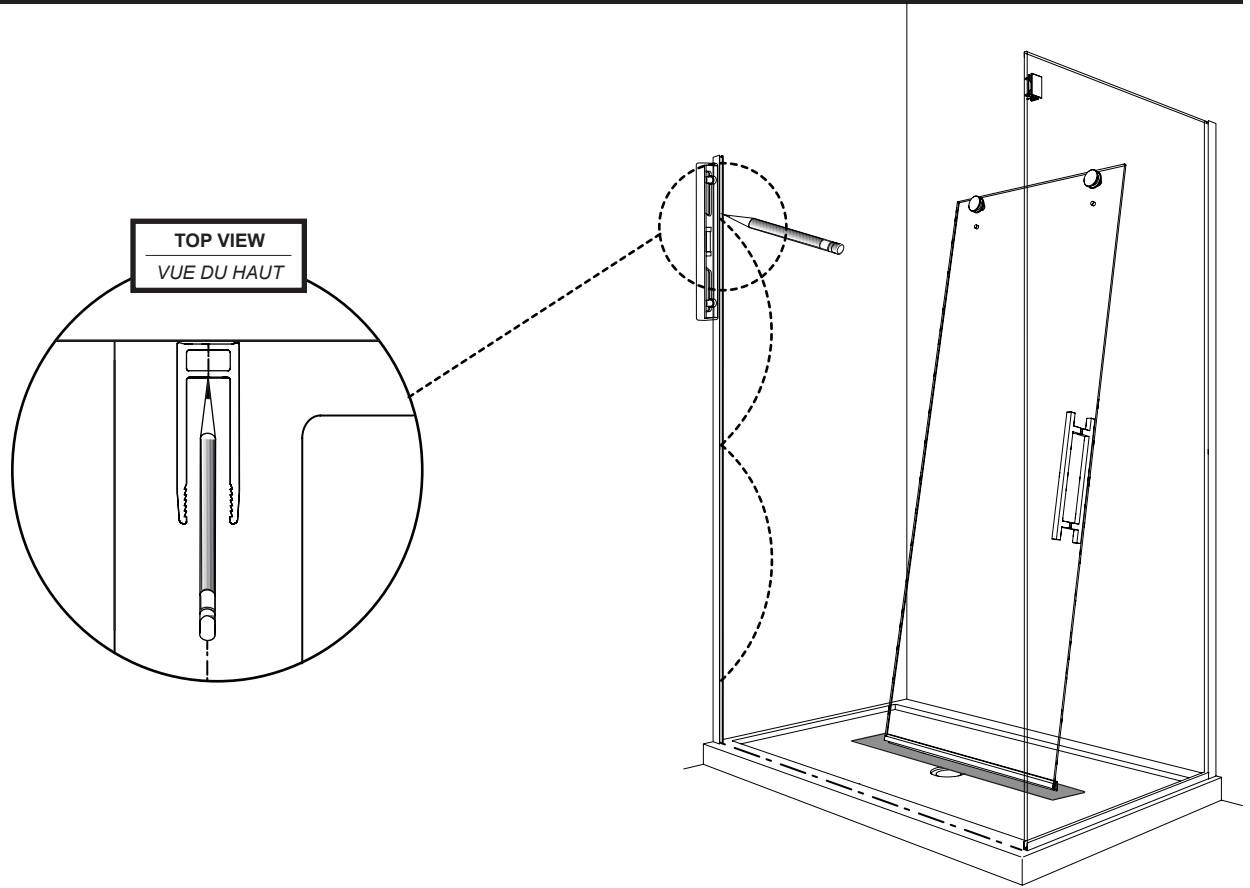

**24** DRILL, APPLY SILICONE & INSERT THE WALL PLUGS  
*PERCER, APPLIQUER DU SILICONE ET INSÉRER LES CHEVILLES*

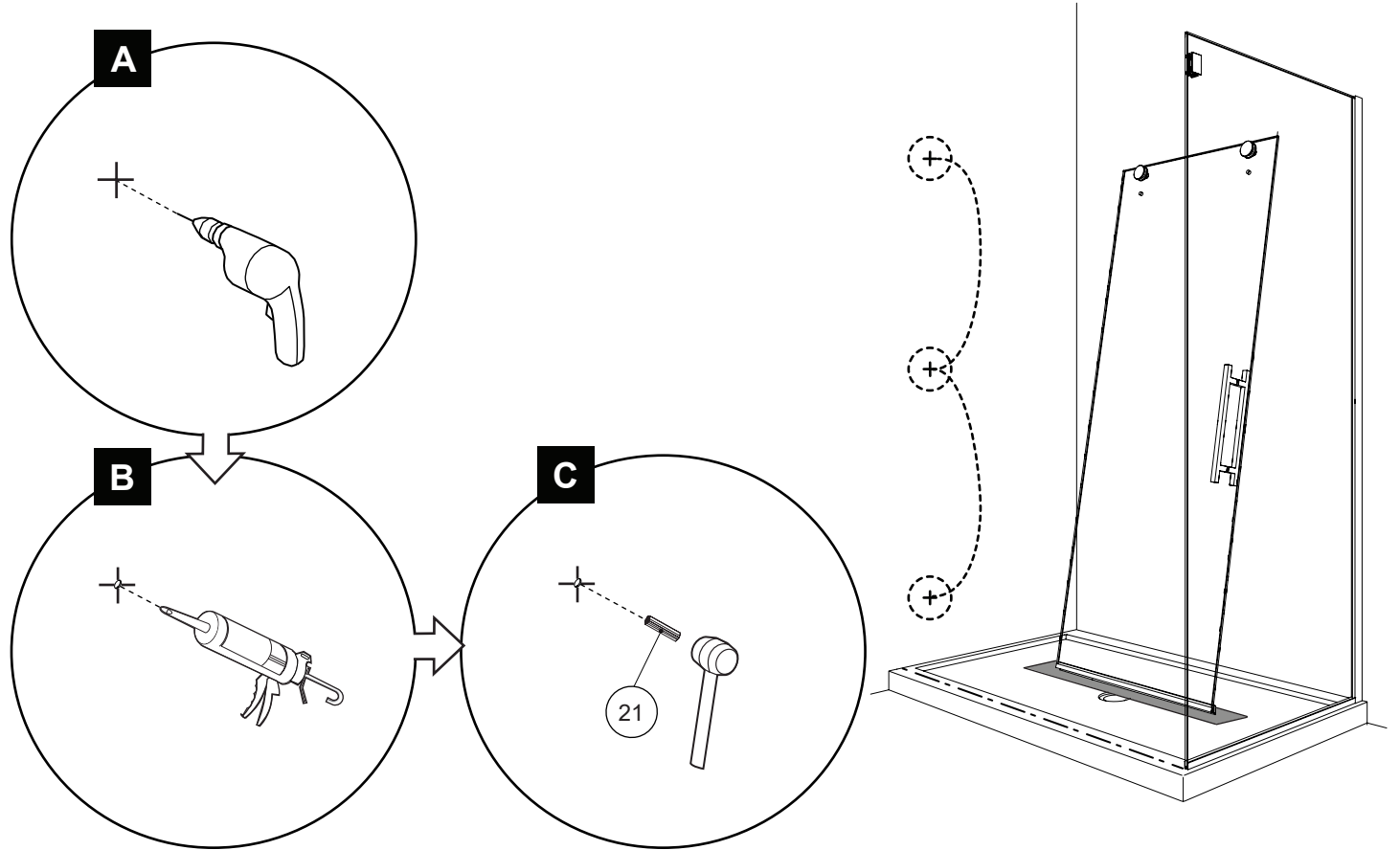

25

SILICONE AND SECURE THE WALL JAMB  
CALFEUTRER ET SÉCURISER LE JAMBAGE

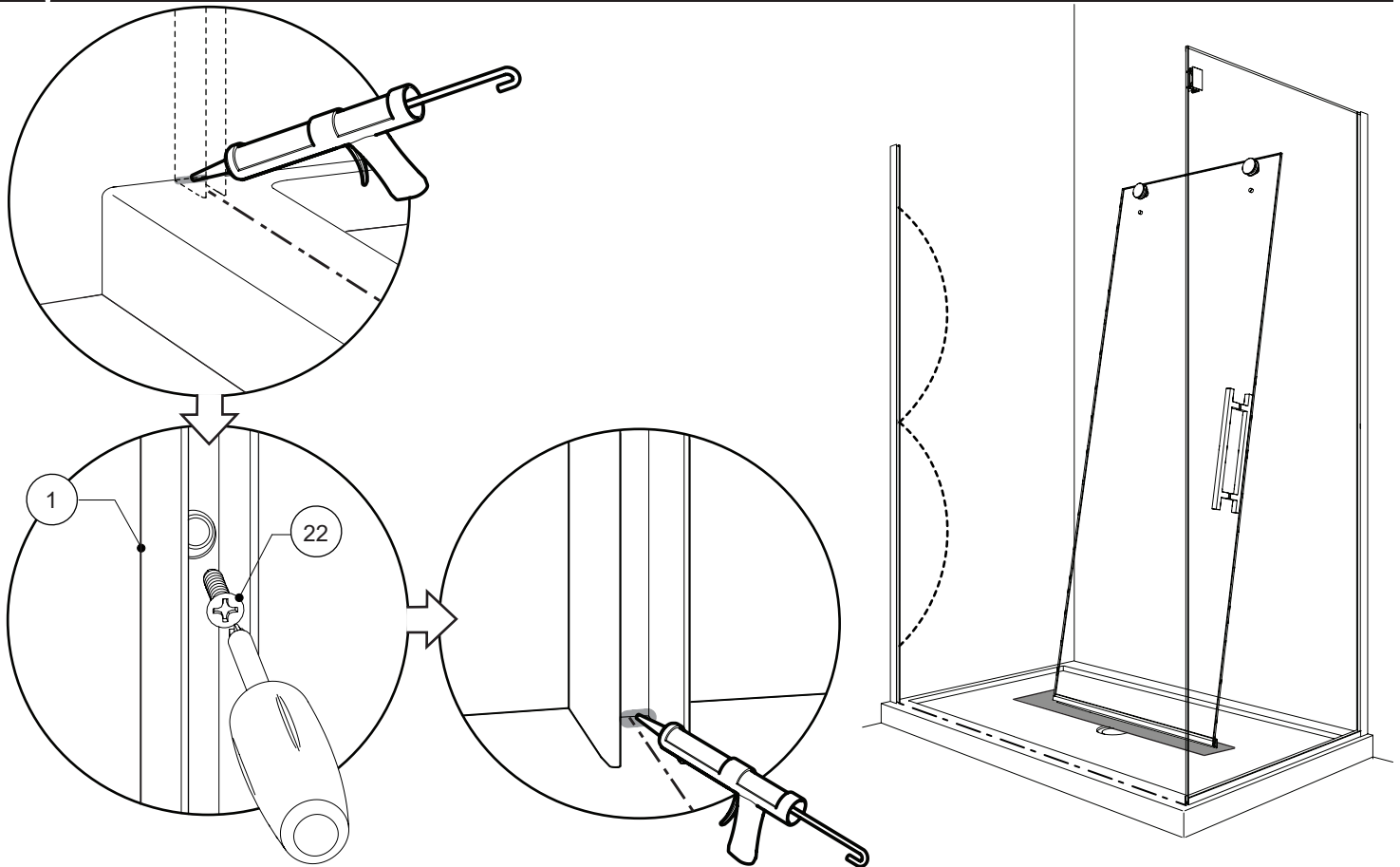

26

TEMPORARILY PLACE THE U-CHANNEL FOR FIXED PANEL  
PLACER LE PROFILÉ EN «U» POUR LE PANNEAU FIXE TEMPORAIREMENT

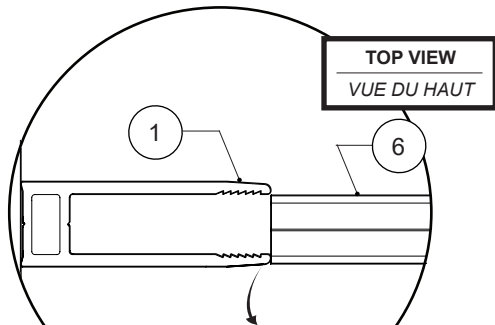
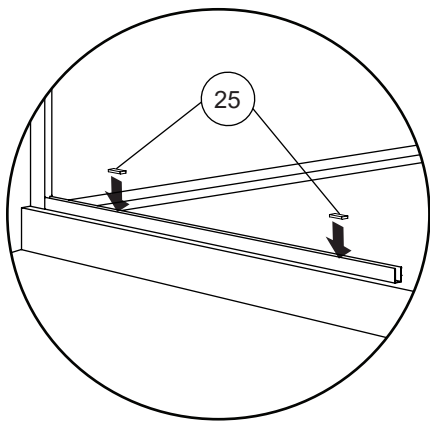

TOP VIEW  
VUE DU HAUT

Make sure the U-channel is flush with exterior of walljamb  
S'assurer que le profilé en «U» est aligné avec l'extérieur du jambage

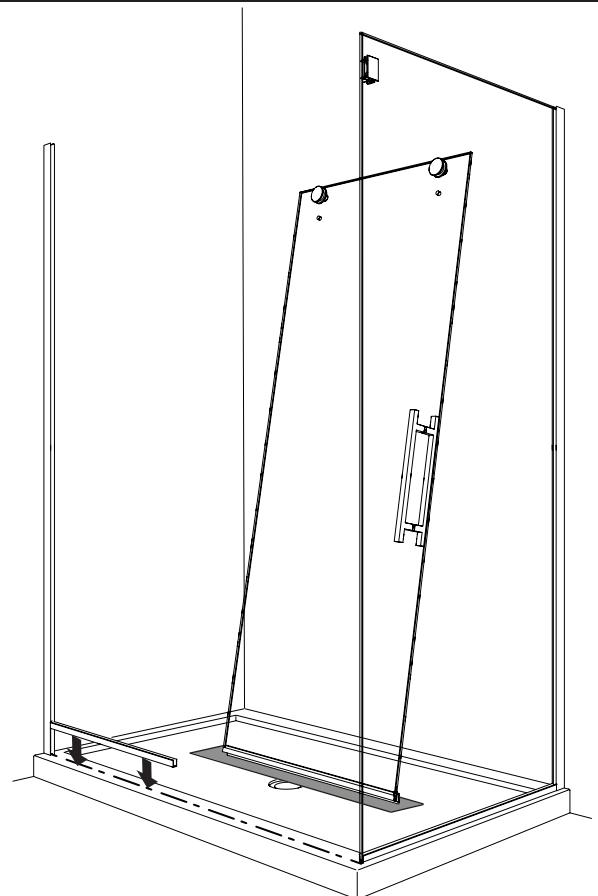



Cut the running rail 2 5/8" (67mm) shorter than the opening.  
Trim the running rail on the side with no holes

Couper la barre de roulement 2 5/8" (67mm) plus court que l'ouverture. Couper la barre de roulement du côté sans trous

Glass fastener holes  
(fixed panel side).

Trous des fixations de verre  
(côté du panneau fixe).

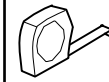
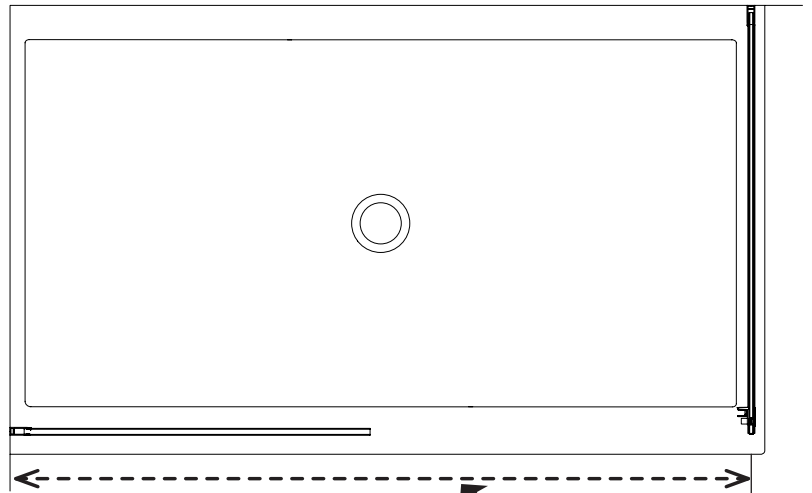
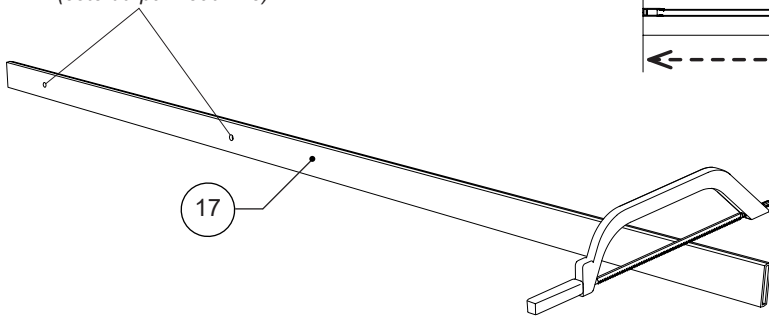

Opening starts from finished wall  
to center of return panel

L'ouverture est du mur fini au  
centre du panneau de retour



After sliding the brackets onto the rail, slightly tighten the set screws to prevent the brackets from sliding. Do not tighten the set screws too much, as they will damage the rail.

Après avoir inséré les supports sur le rail, serrer légèrement les vis de réglage pour empêcher les supports de glisser. Ne pas trop serrer les vis de réglage, car elles peuvent endommager le rail.

Glass fastener holes  
(fixed panel side).

Trous des fixations de verre  
(côté du panneau fixe).

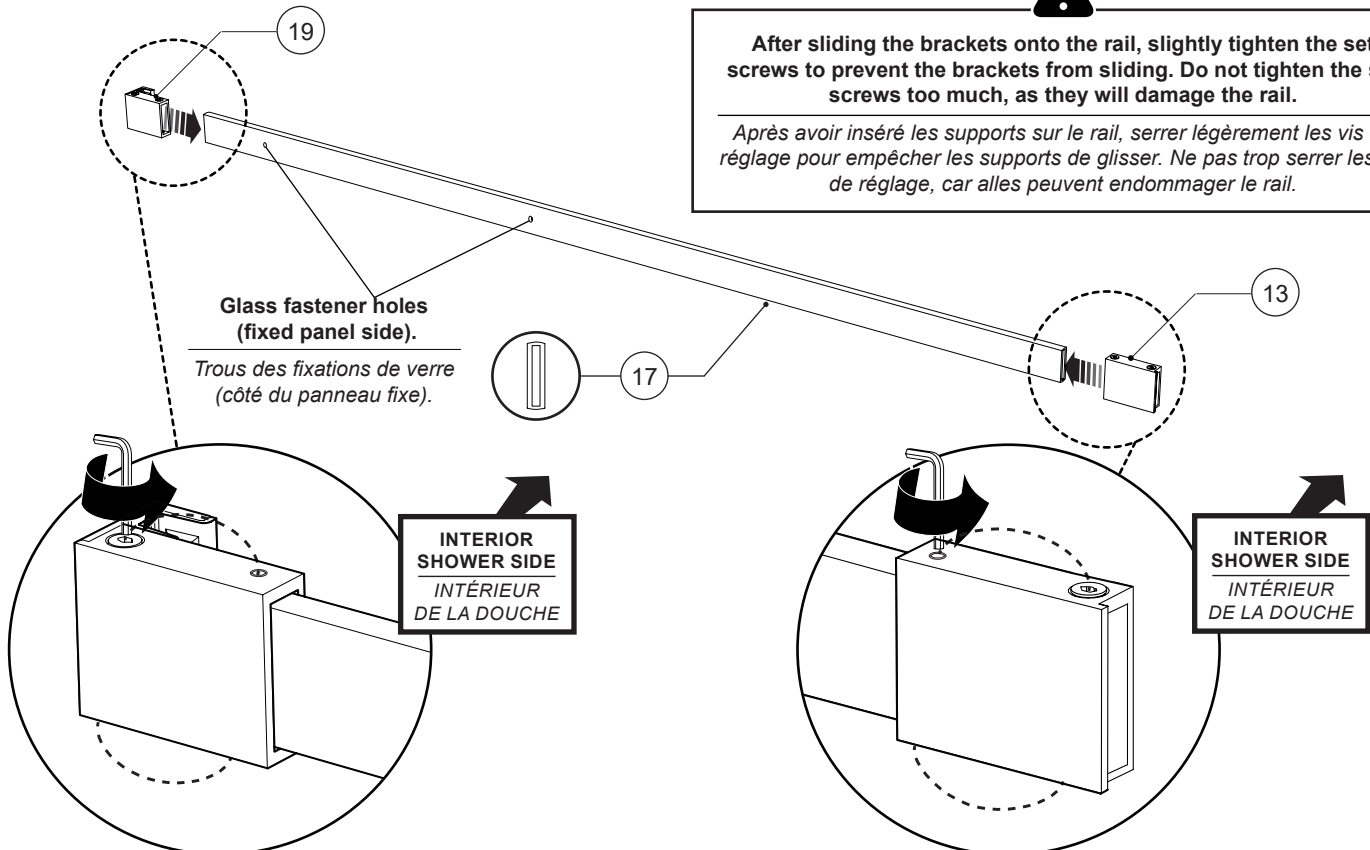

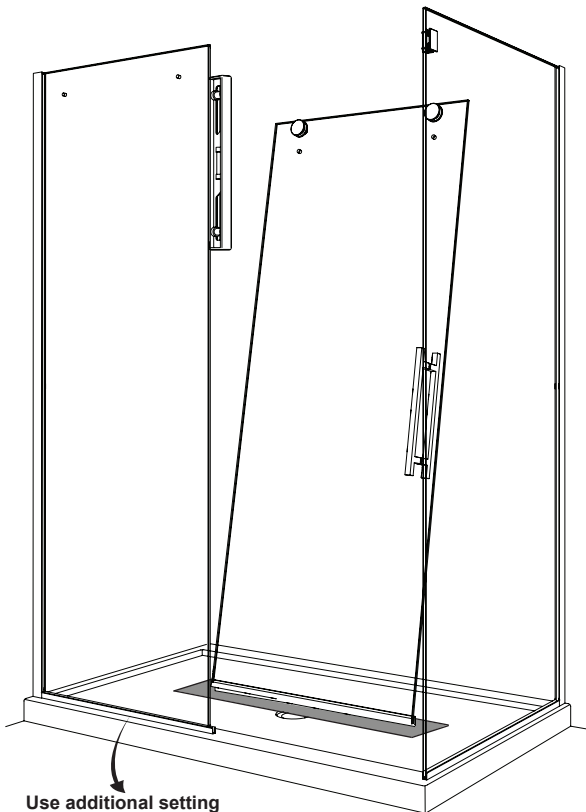
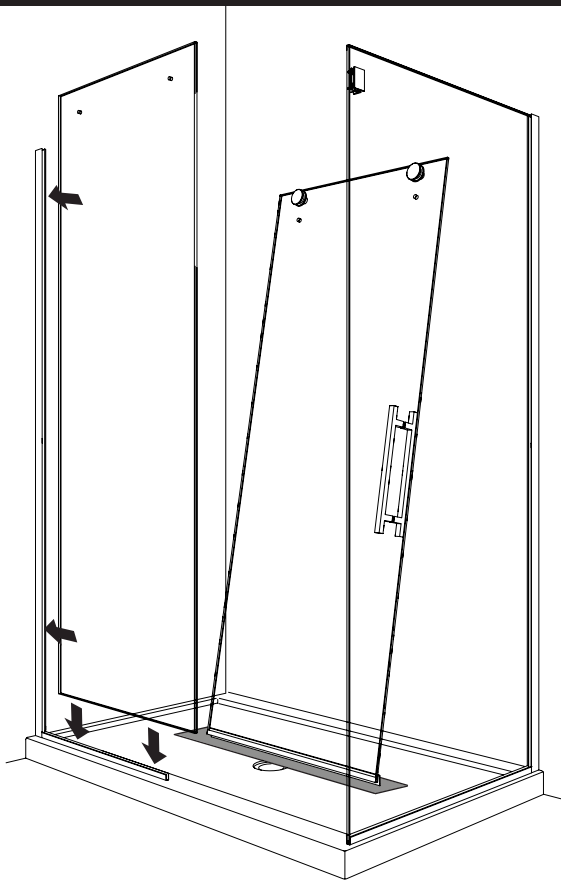

Use additional setting blocks to adjust if necessary.  
*Utiliser des blocs de niveau transparents supplémentaires pour ajuster si nécessaire.*

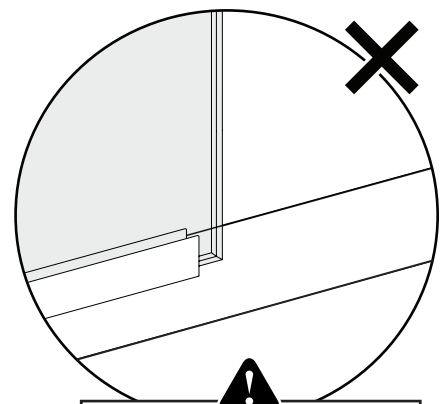

**Fixed panel can't exceed the U-channel**  
*Le panneau fixe ne peut pas dépasser le profilé en «U»*

**31**

**INSTALL THE RUNNING RAIL ONTO THE FIXED PANEL WITH THE GLASS FASTENERS**  
**INSTALLER LA BARRE DE ROULEMENT AVEC LES FIXATIONS DE VERRE**

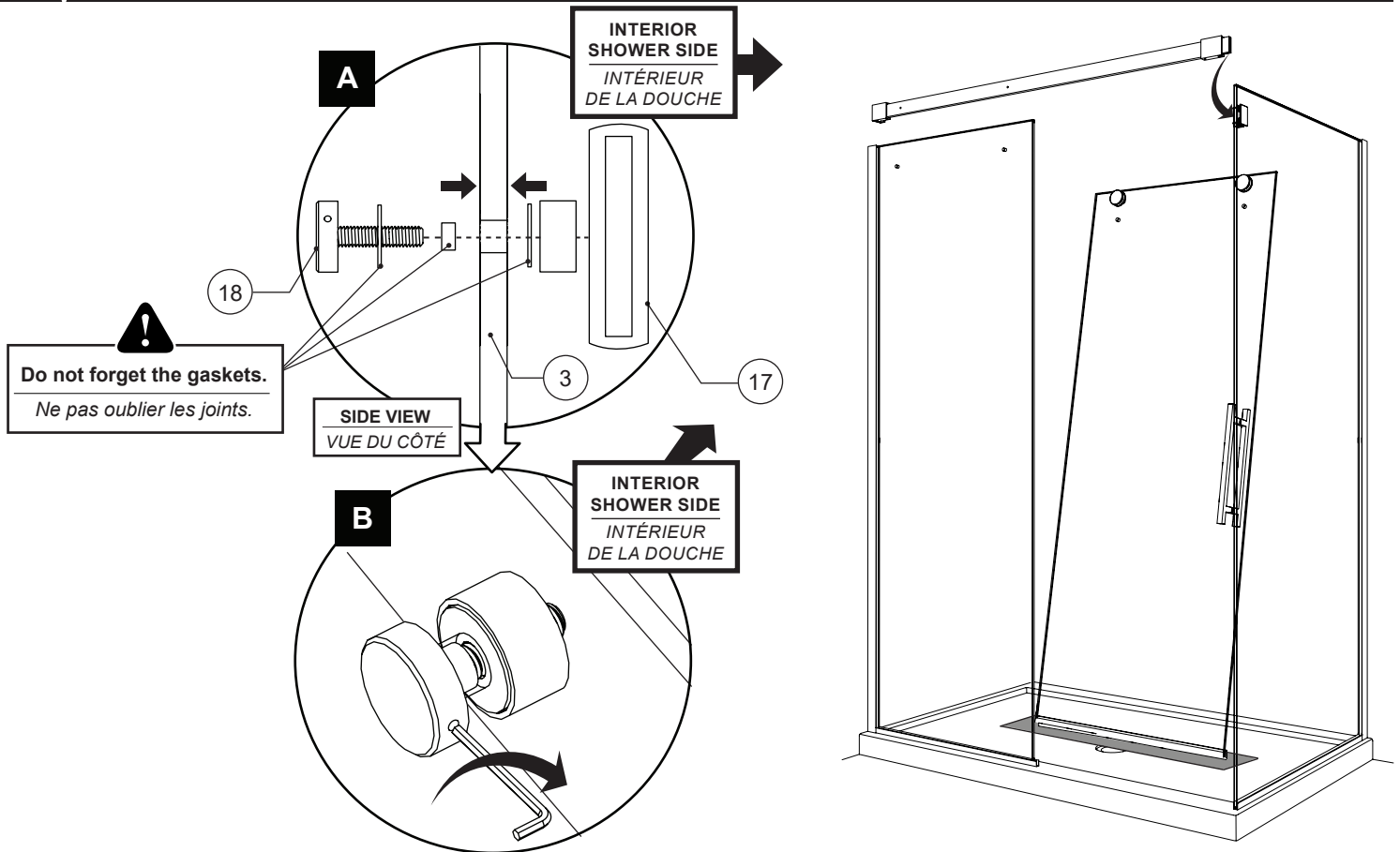
**32**

**LEVEL THE RUNNING RAIL, SLIDE THE BRACKETS AGAINST THE WALL AND MARK THEIR PLACEMENT**  
**NIVELER LA BARRE DE ROULEMENT, GLISSER LES SUPPORTS VERS LE MUR ET MARQUER L'EMPLACEMENT**

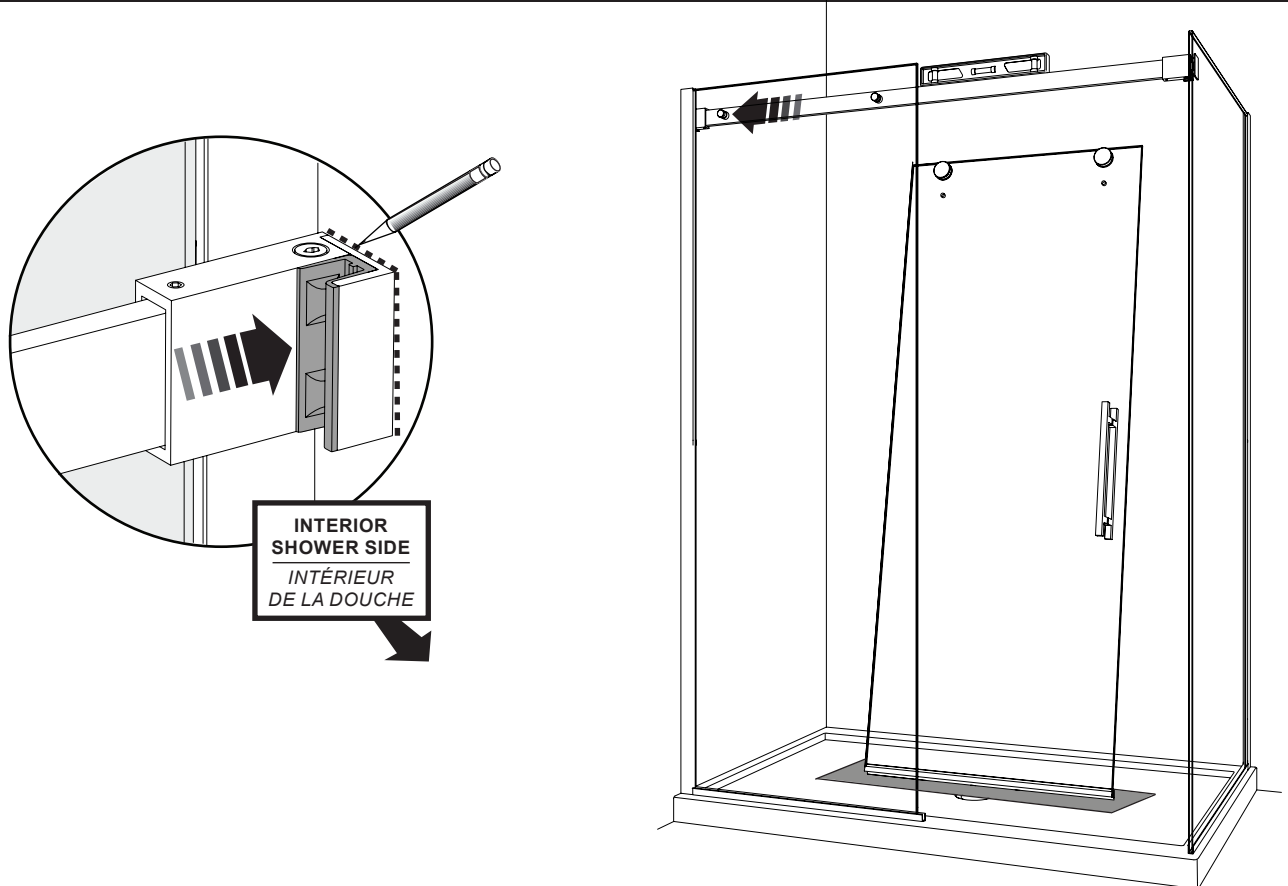

**33**

**MARK THE U-CHANNEL CUT LINE ACCORDING TO THE GUIDE**  
**MARQUER LA LIGNE DE COUPE DU PROFILÉ EN «U» SUIVANT LA POSITION DU GUIDE**

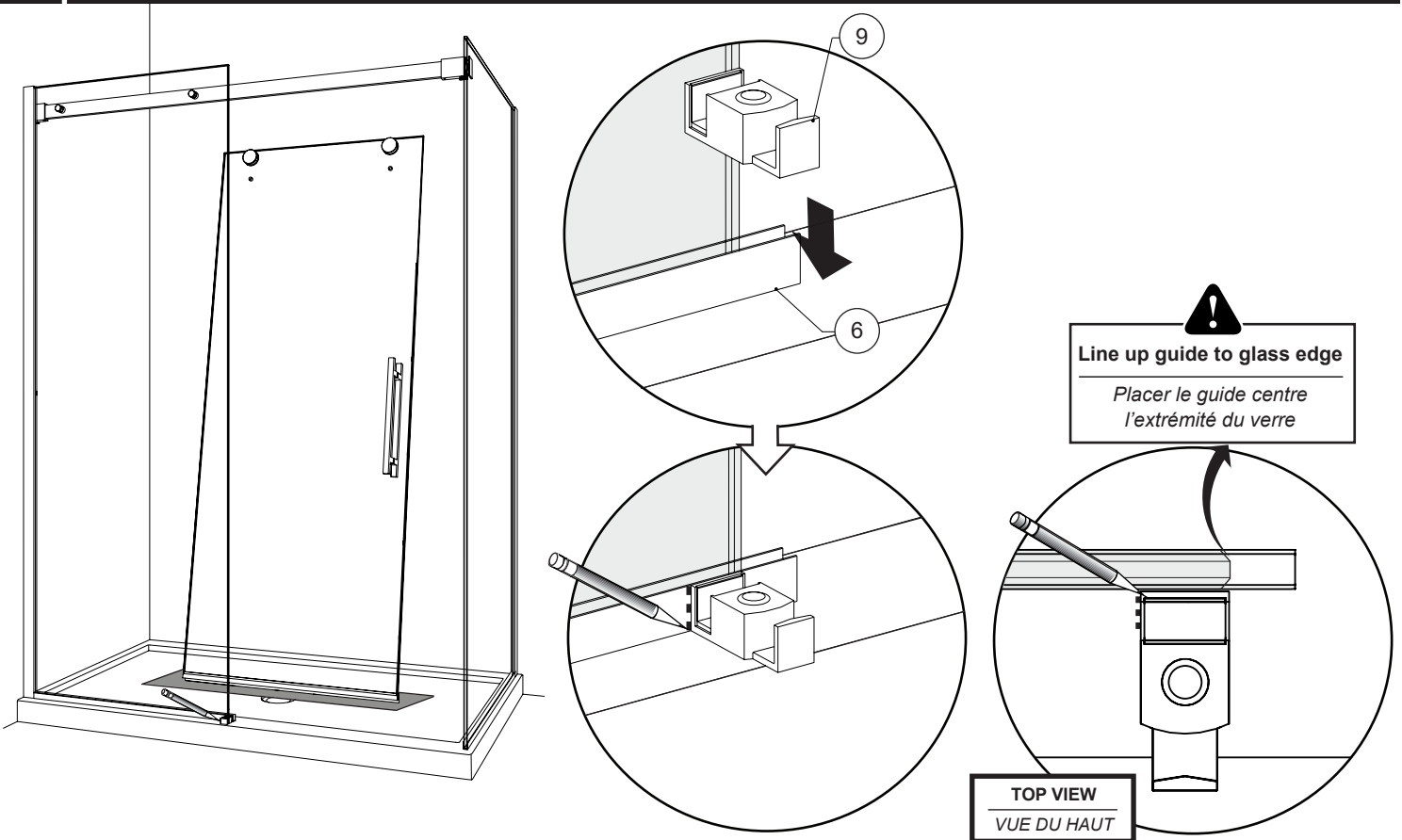
**34**

**REMOVE THE RUNNING RAIL, FIXED PANEL AND U-CHANNEL**  
**ENLEVER LA BARRE DE ROULEMENT LE PANNEAU FIXE ET LE PROFILÉ EN U»**

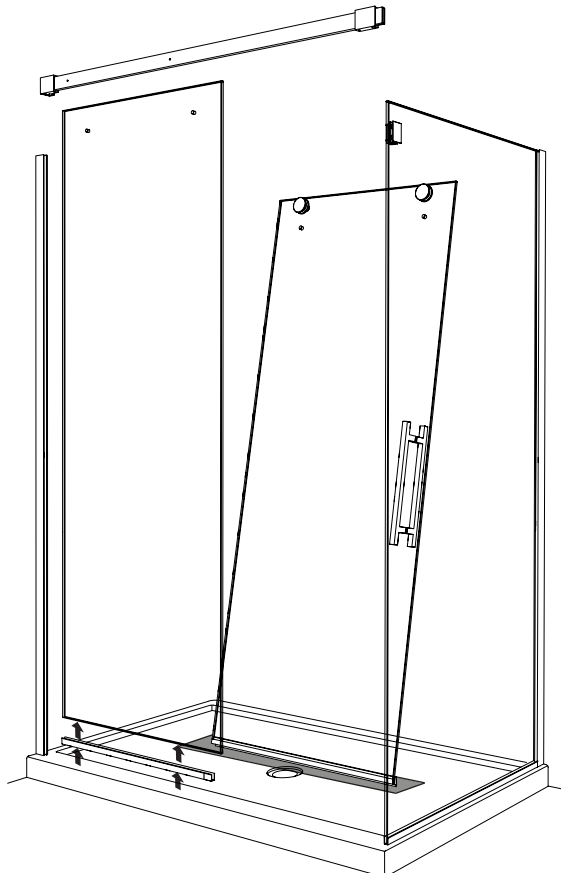

35

**CUT THE U-CHANNEL FOR THE FIXED PANEL**  
*COUPER LE PROFILÉ EN «U» POUR LE PANNEAU FIXE*

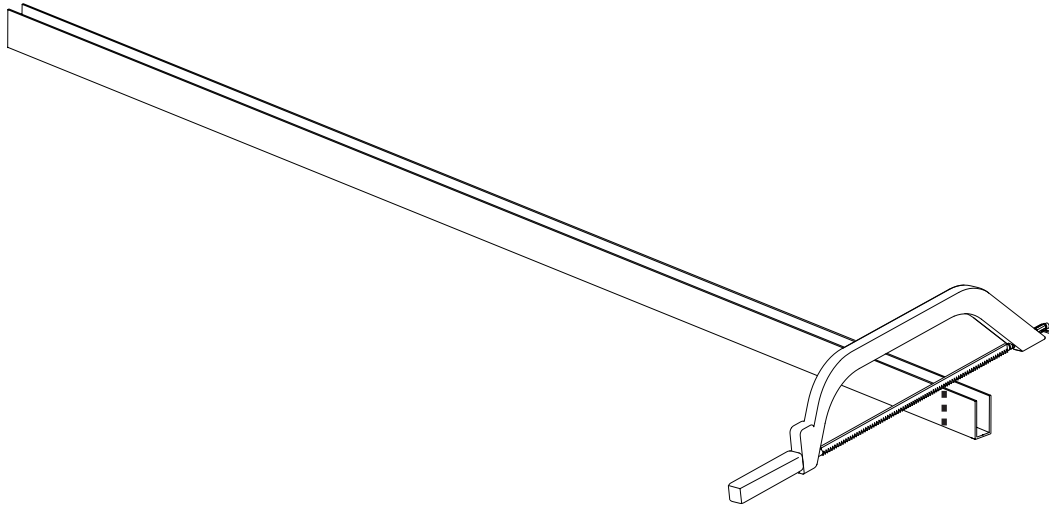

36

**INSTALL THE U-CHANNEL FOR FIXED PANEL**  
*INSTALLER LE PROFILÉ EN «U» POUR LE PANNEAU FIXE*

**A**



**Wipe the base with a clean cloth before installing the U-channel.**

*Essuyer la base avec un chiffon propre avant d'installer le profilé en «U».*

**B**

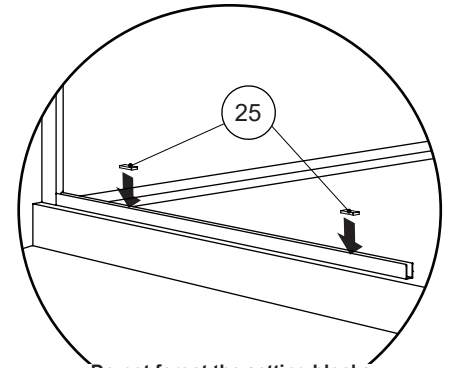
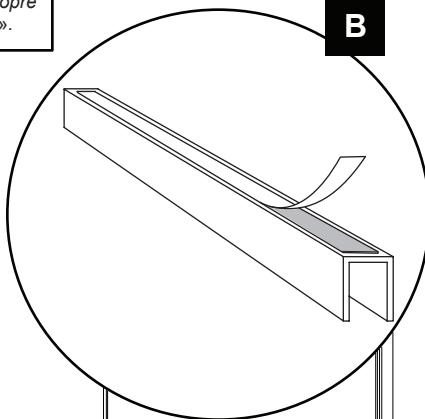

**Do not forget the setting blocks.**

*Ne pas oublier les blocs de niveau transparents.*

**TOP VIEW**  
*VUE DU HAUT*

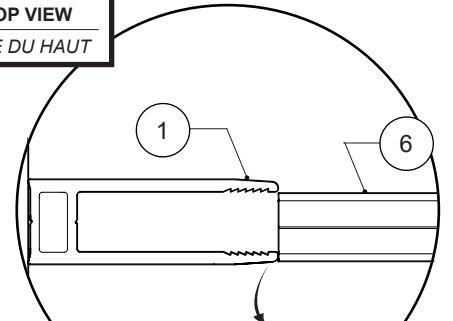

**Make sure the U-channel is flush with exterior of walljamb**

*S'assurer que le profilé en «U» est aligné avec l'extérieur du jambage*

37

**PLACE AND MARK THE BOTTOM GUIDE PLACEMENT**  
*PLACER ET MARQUER L'EMPLACEMENT DU GUIDE*

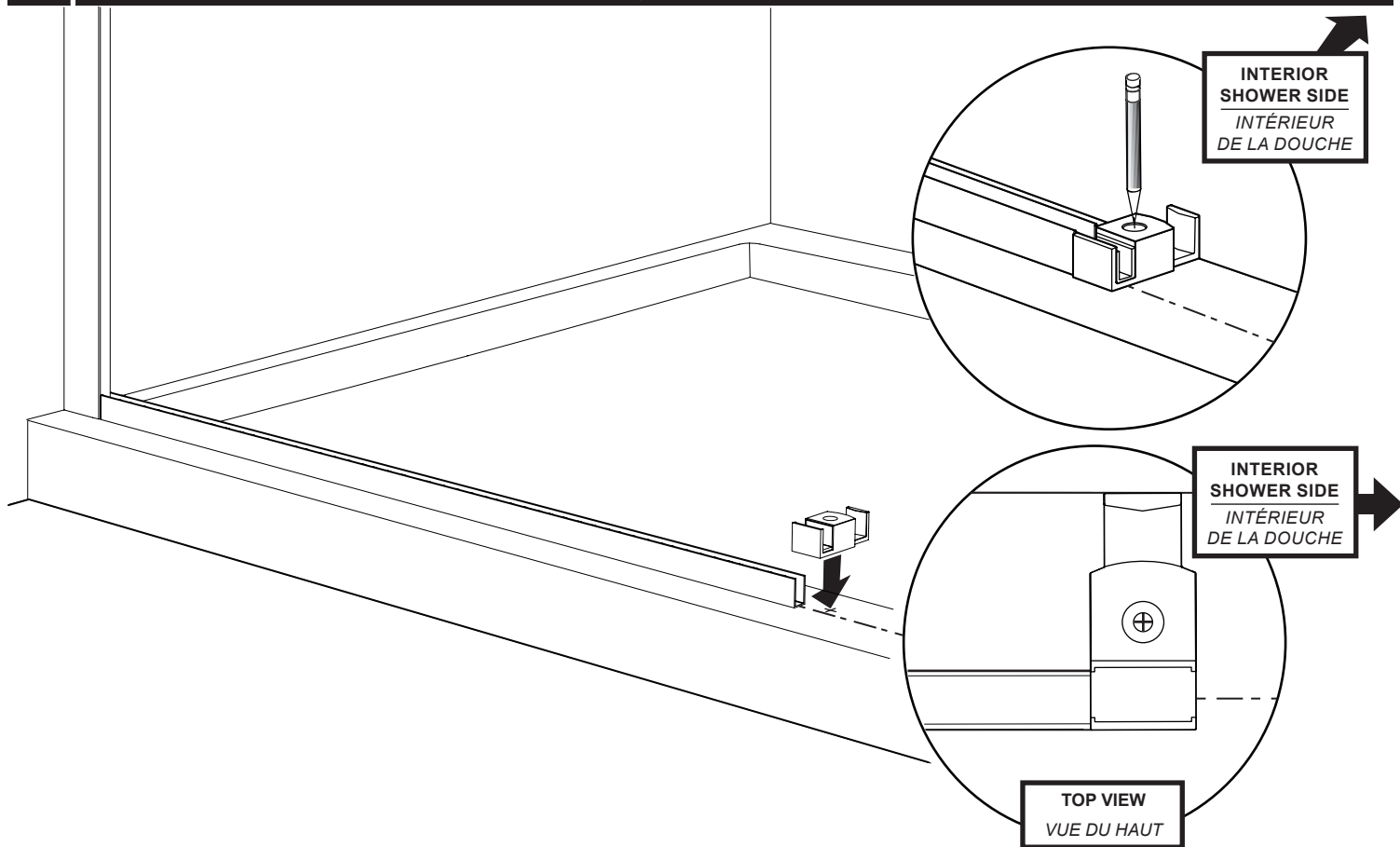

38

**DRILL AND SILICONE THE BOTTOM GUIDE PLACEMENT**  
*PERCER ET CALFEUTRER L'EMPLACEMENT DU GUIDE INFÉRIEUR*

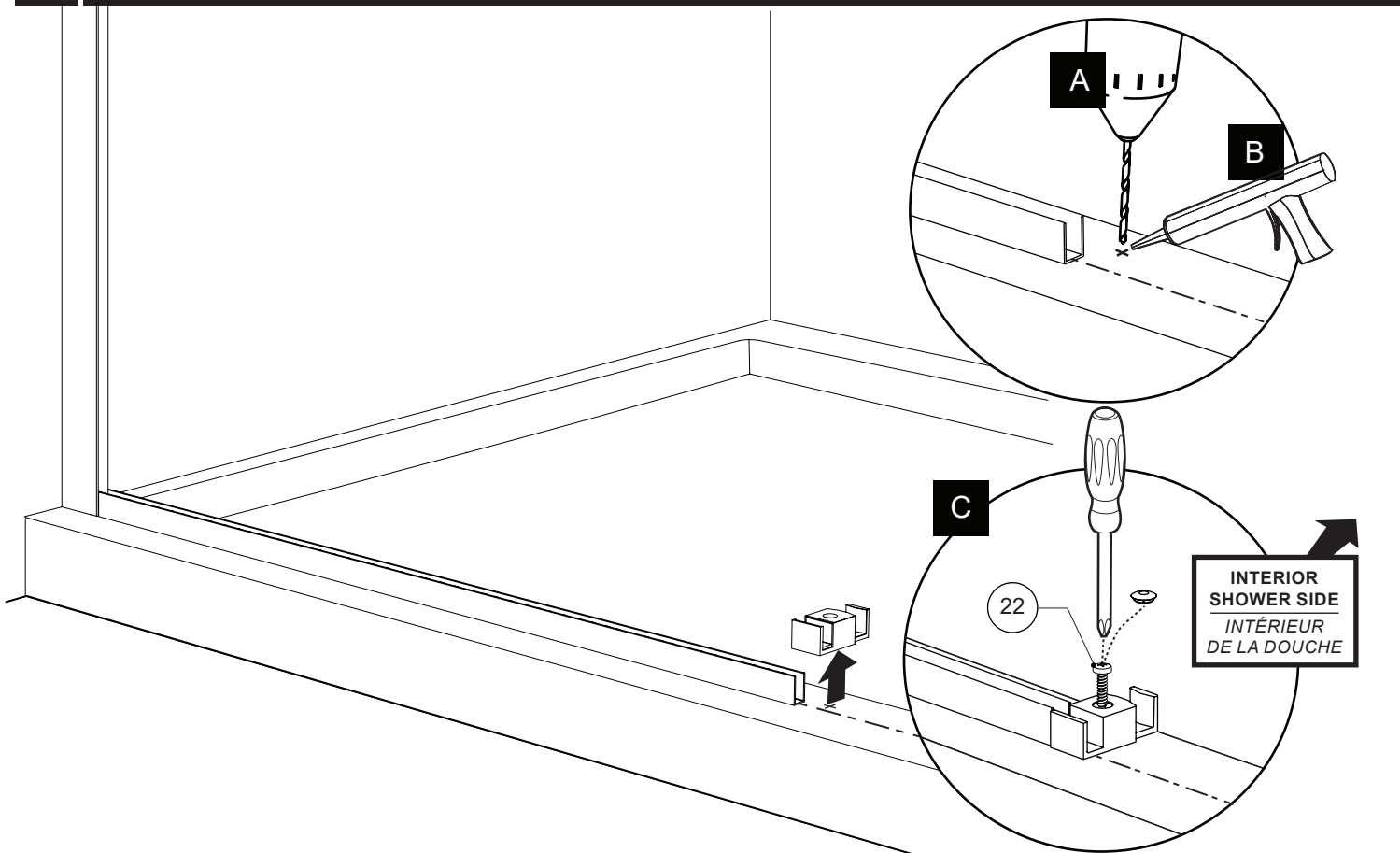

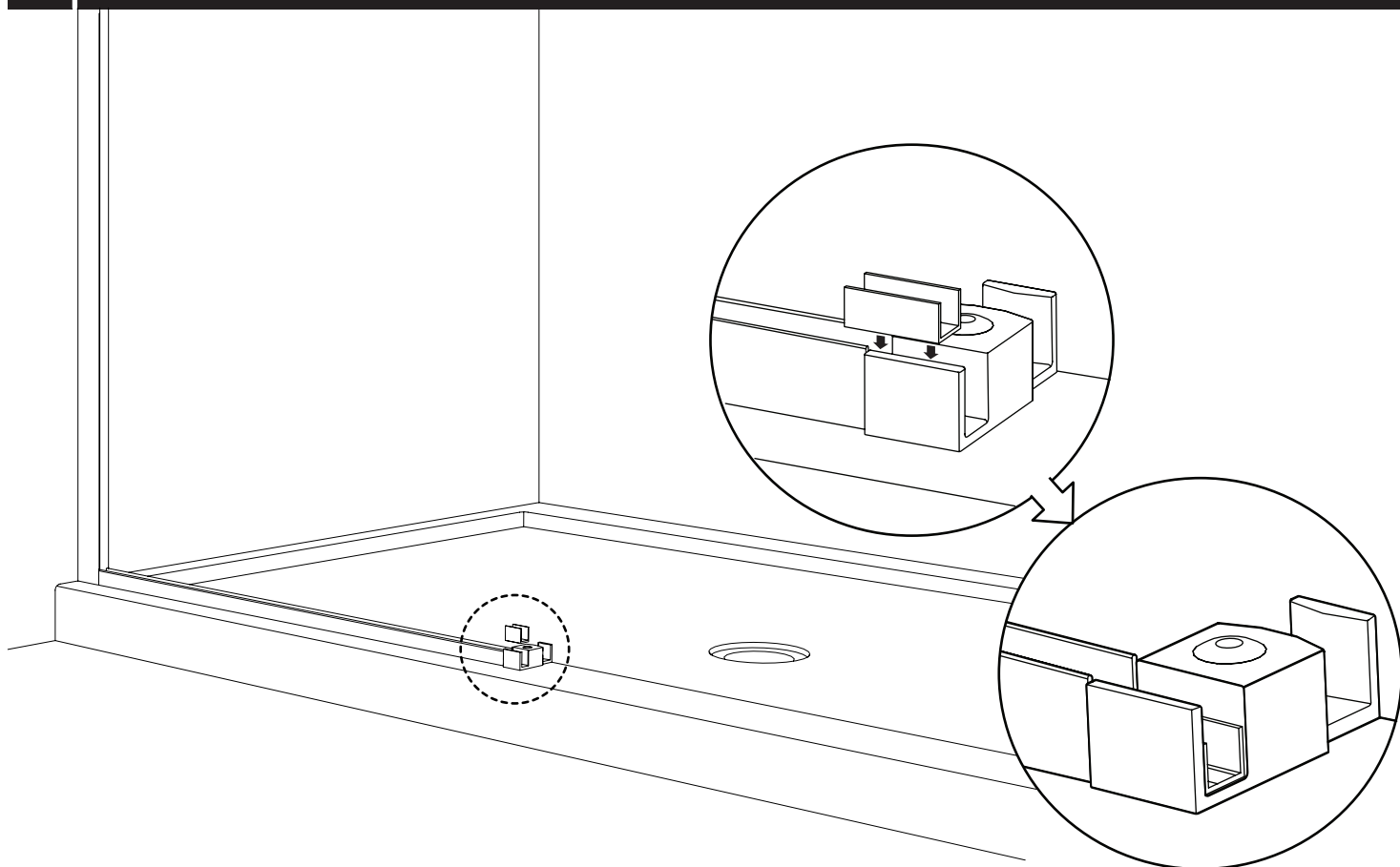
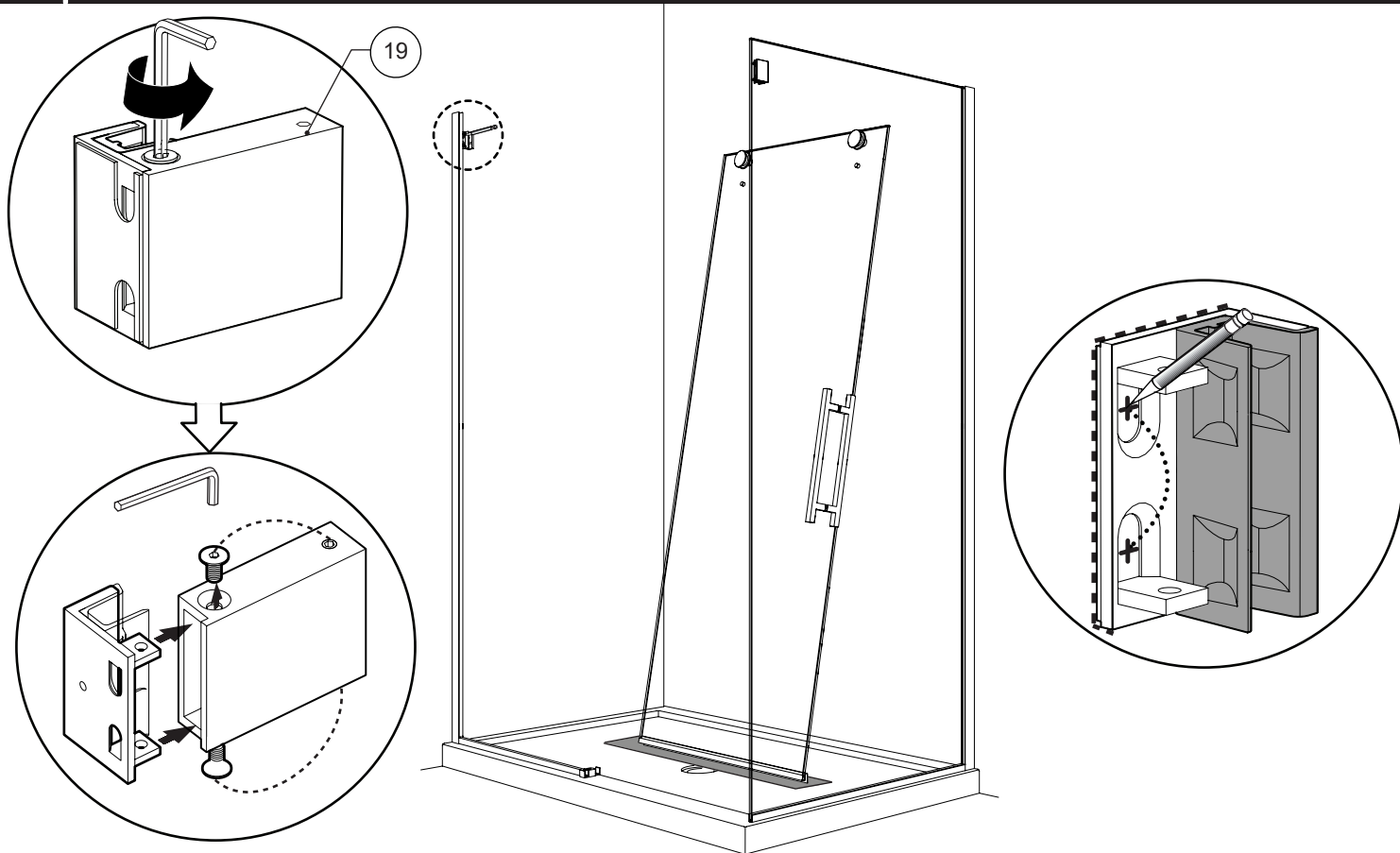

**39****PLACE THE GASKET INTO BOTTOM GUIDE / INSÉRER LE JOINT DANS DU GUIDE INFÉRIEUR****40****PLACE THE PLATE OF WALL MOUNT BRACKET ON THE PREVIOUS MARK  
PLACER LA PLAQUE ARRIÈRE DU PLAQUE SUR LA MARQUE FAITE PRÉCÉDEMMENT**

41

**DRILL , SILICONE AND INSTALL WALL PLUGS FOR WALL MOUNT BRACKET**  
**PERCER, CALFEUTRER ET INSTALLER LES CHEVILLES POUR LE SUPPORT MURAL**

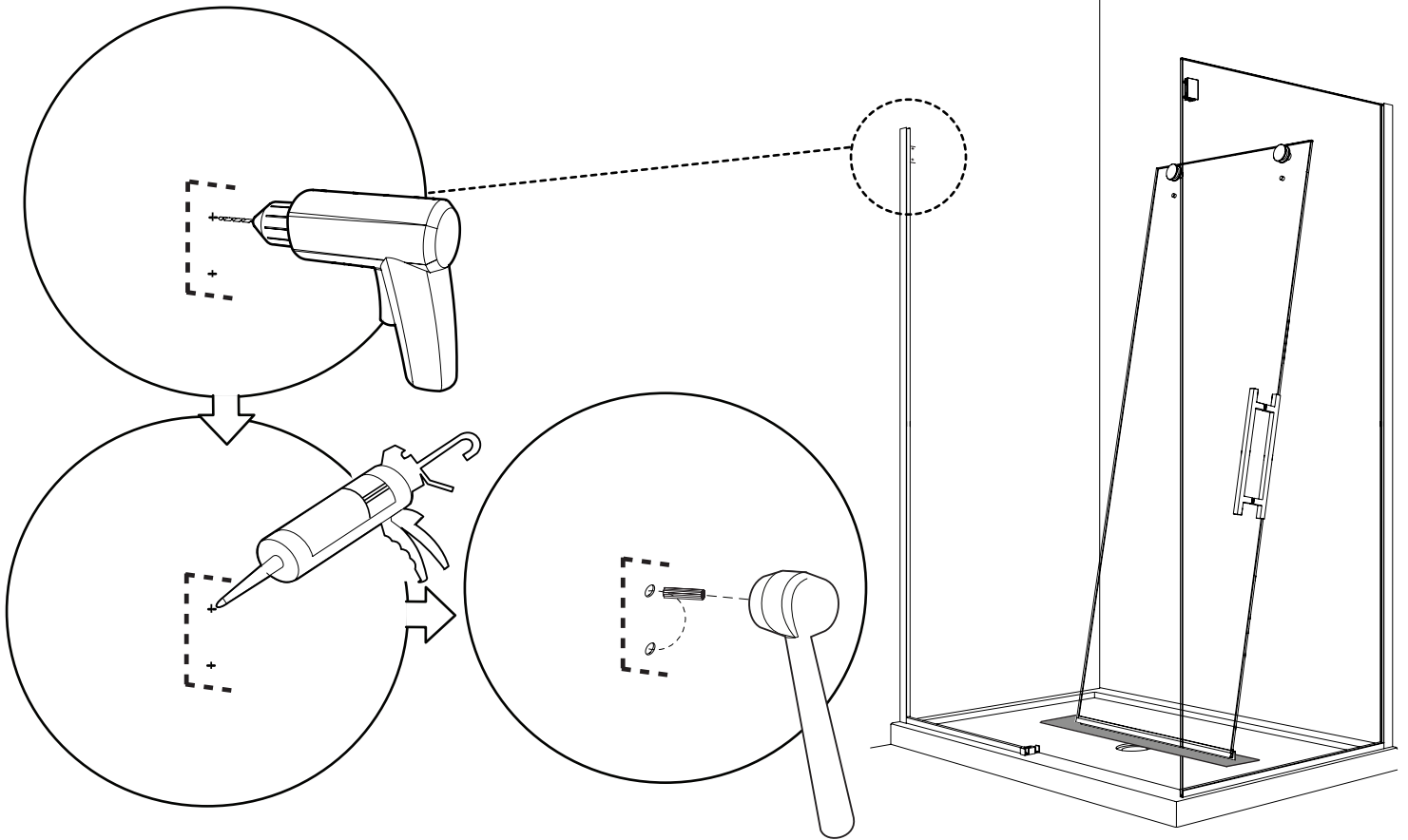

42

**INSTALL THE WALL MOUNT BRACKET / INSTALLER LE SUPPORT MURAL**

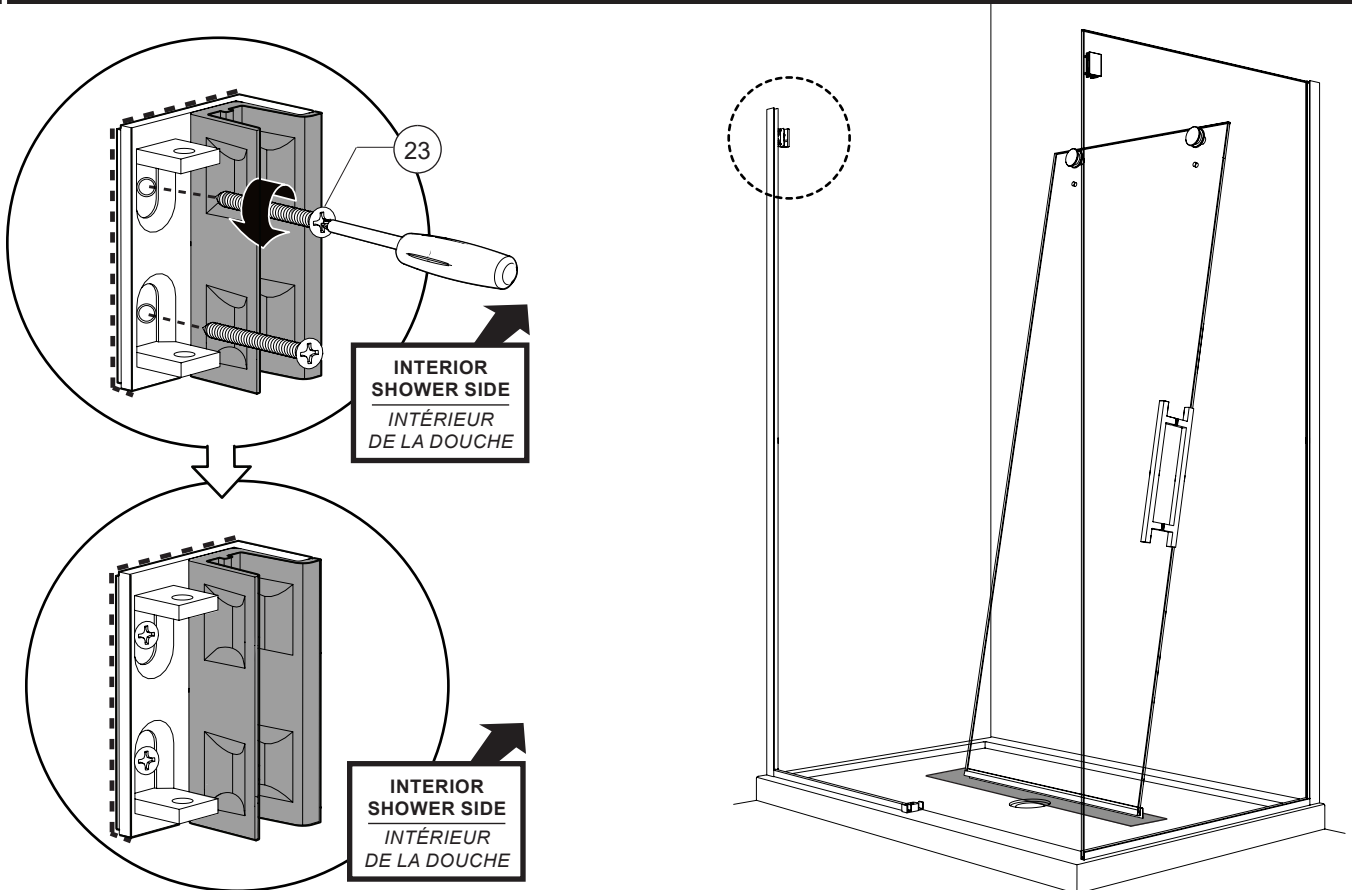

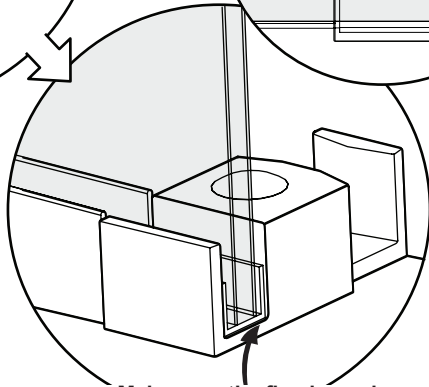
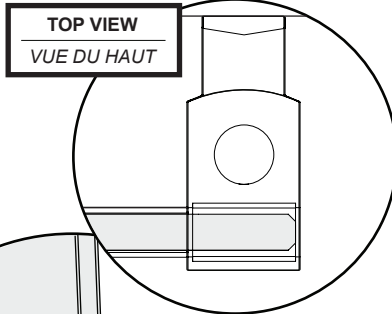
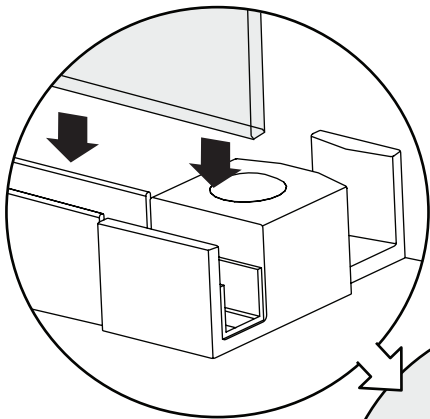

**Make sure the fixed panel is flush with bottom guide**

*S'assurer que le panneau fixe est aligné avec le guide inférieur*

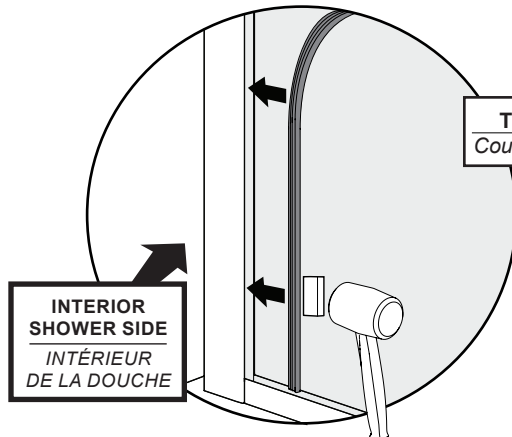
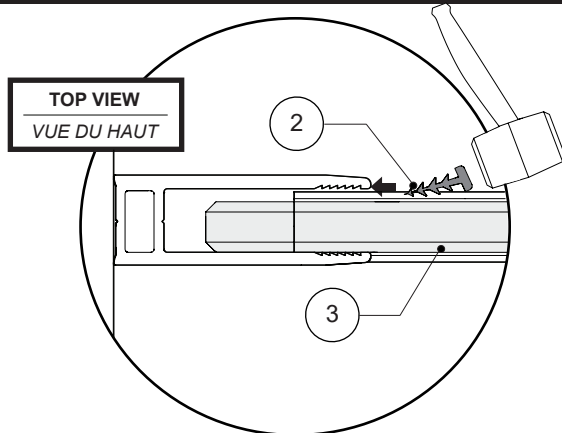
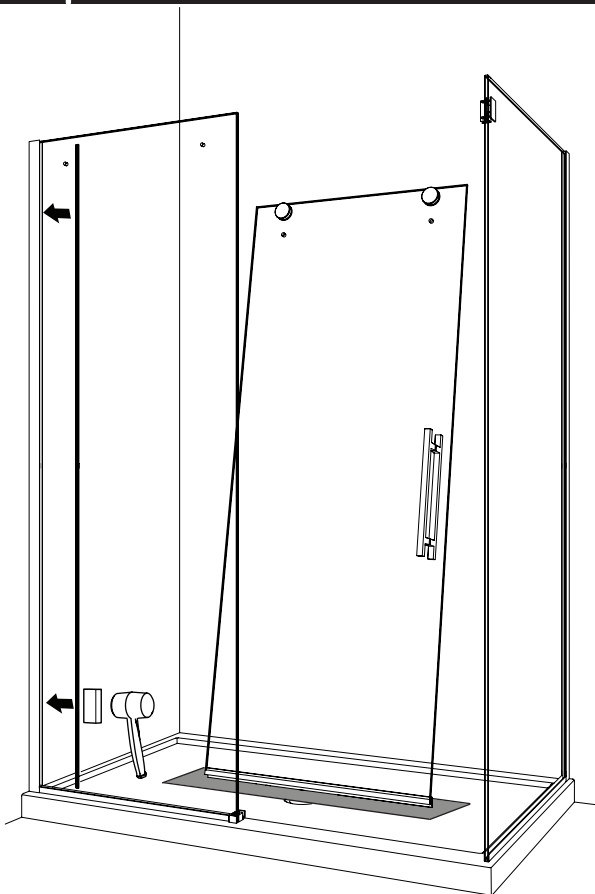
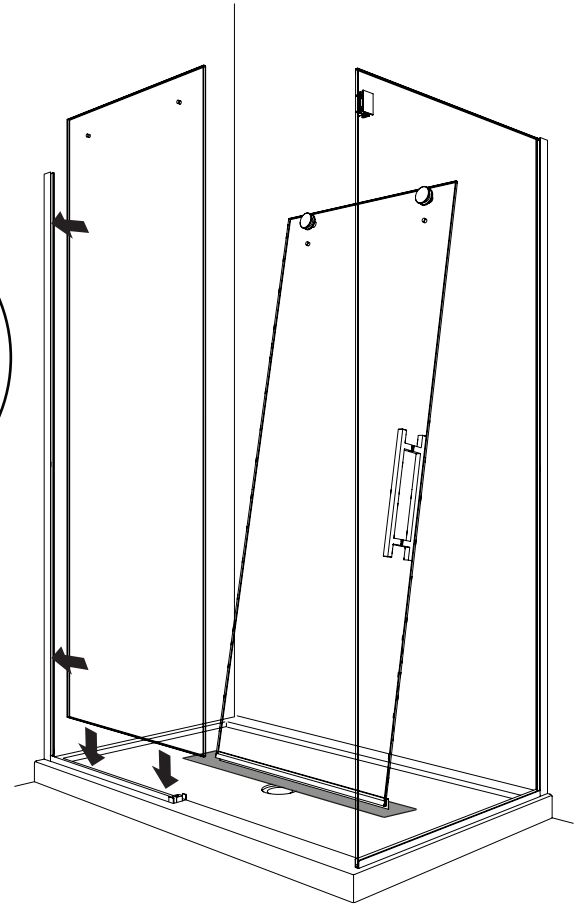

**Trim excess if necessary.**  
*Couper l'excédent si nécessaire.*

**INSERT THE BRACKET INTO THE PLATE WALL MOUNT BRACKET**  
**FIXER LE SUPPORT MURAL À LA PLAQUE INSTALÉÉ AU MUR**

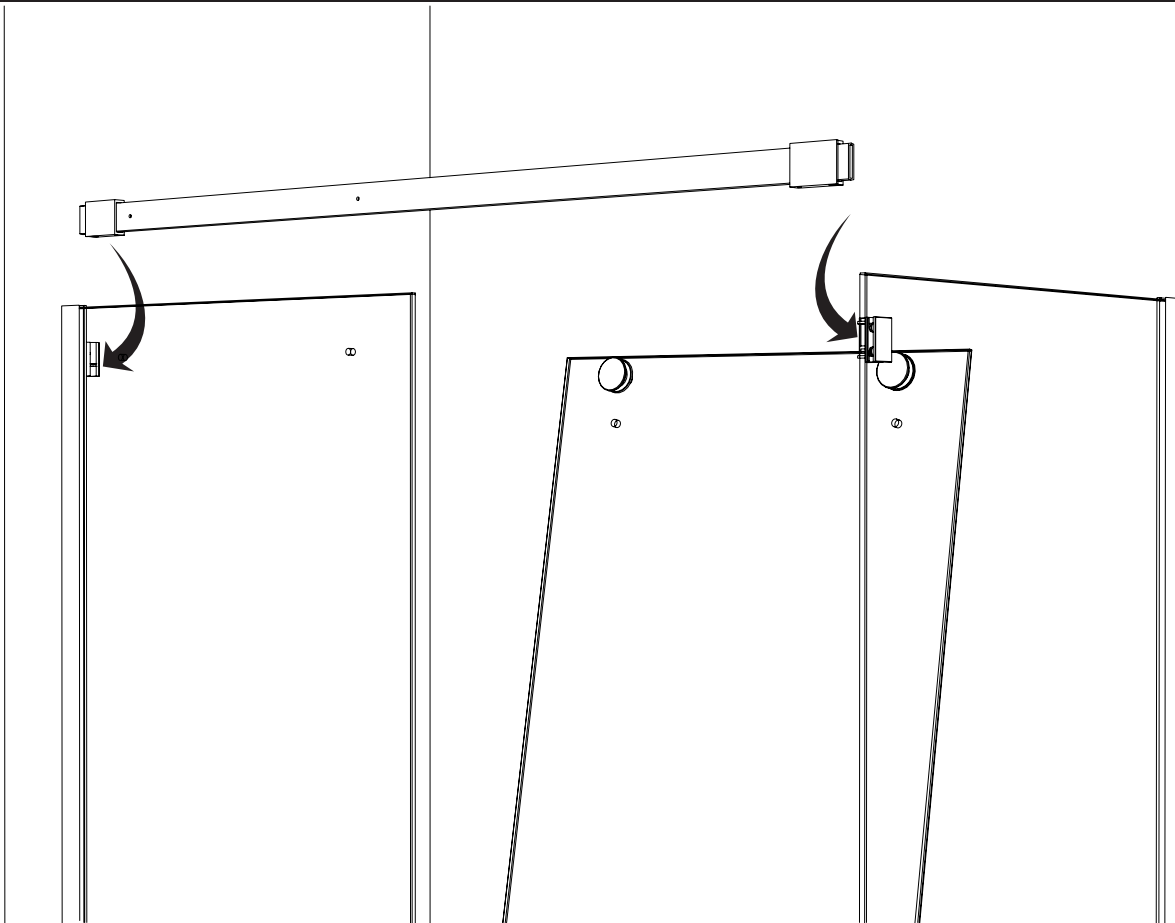

**INSTALL THE RUNNING RAIL ONTO THE FIXED PANEL WITH THE GLASS FASTENERS**  
**INSTALLER LA BARRE DE ROULEMENT AVEC LES FIXATIONS DE VERRE**

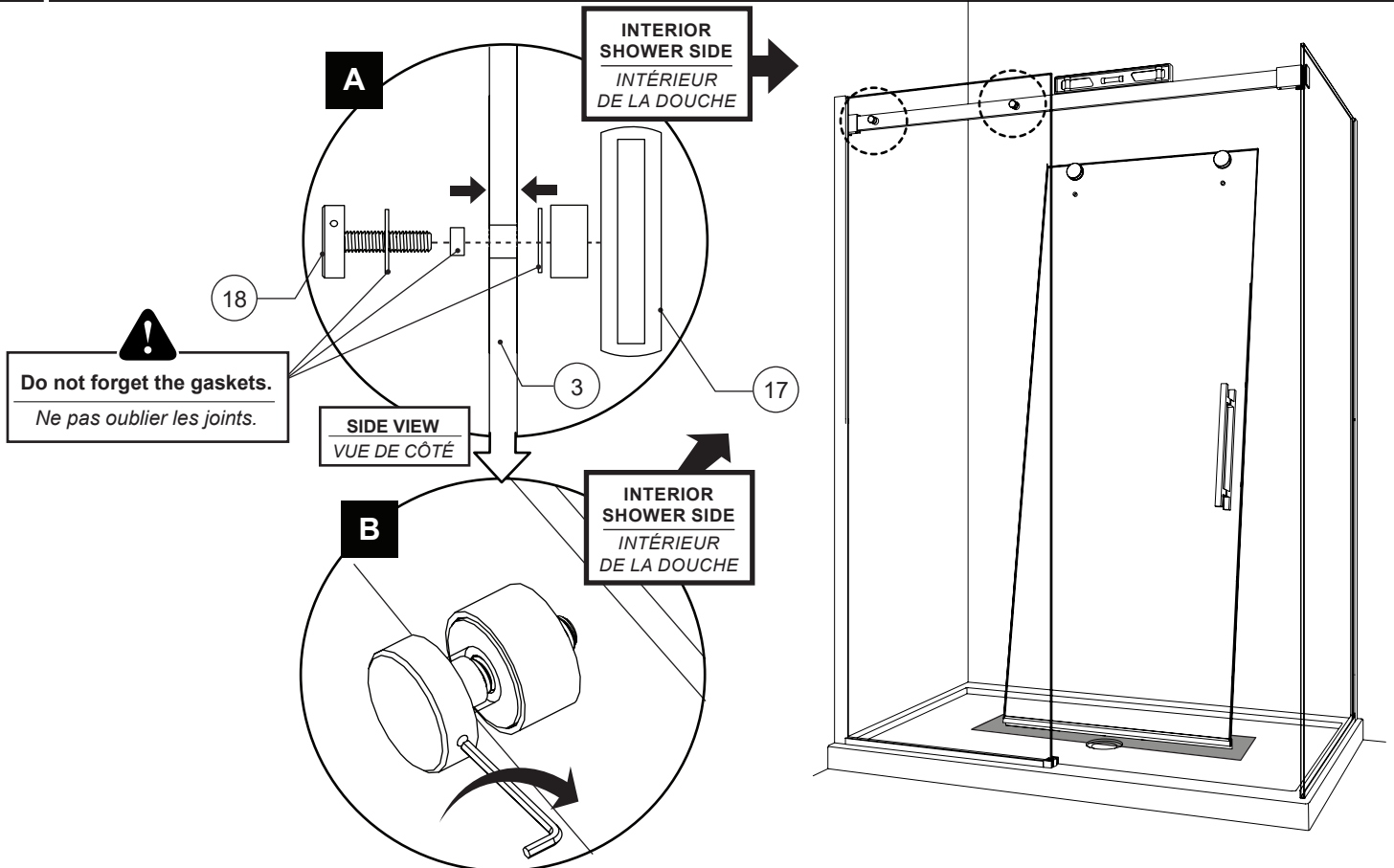

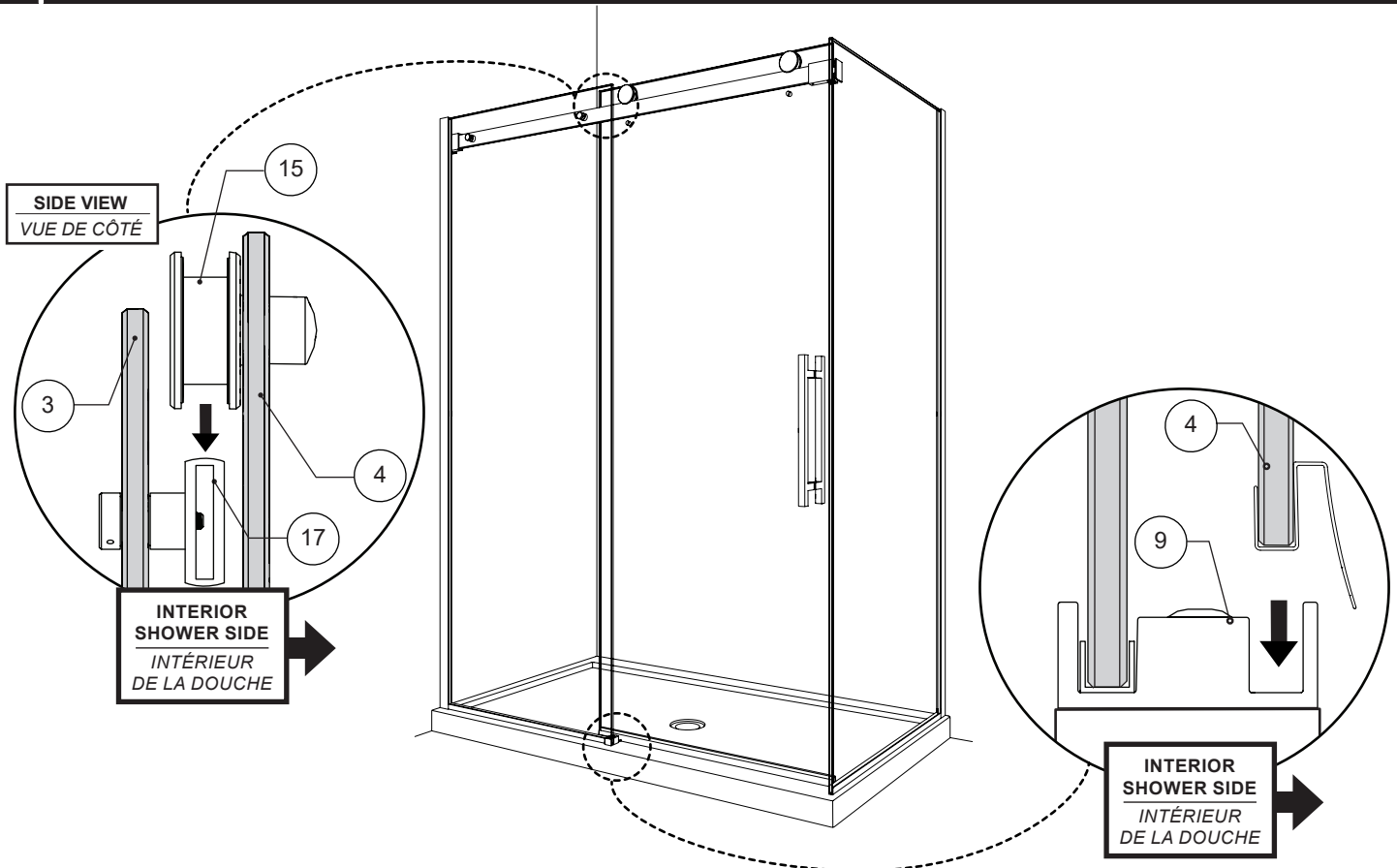
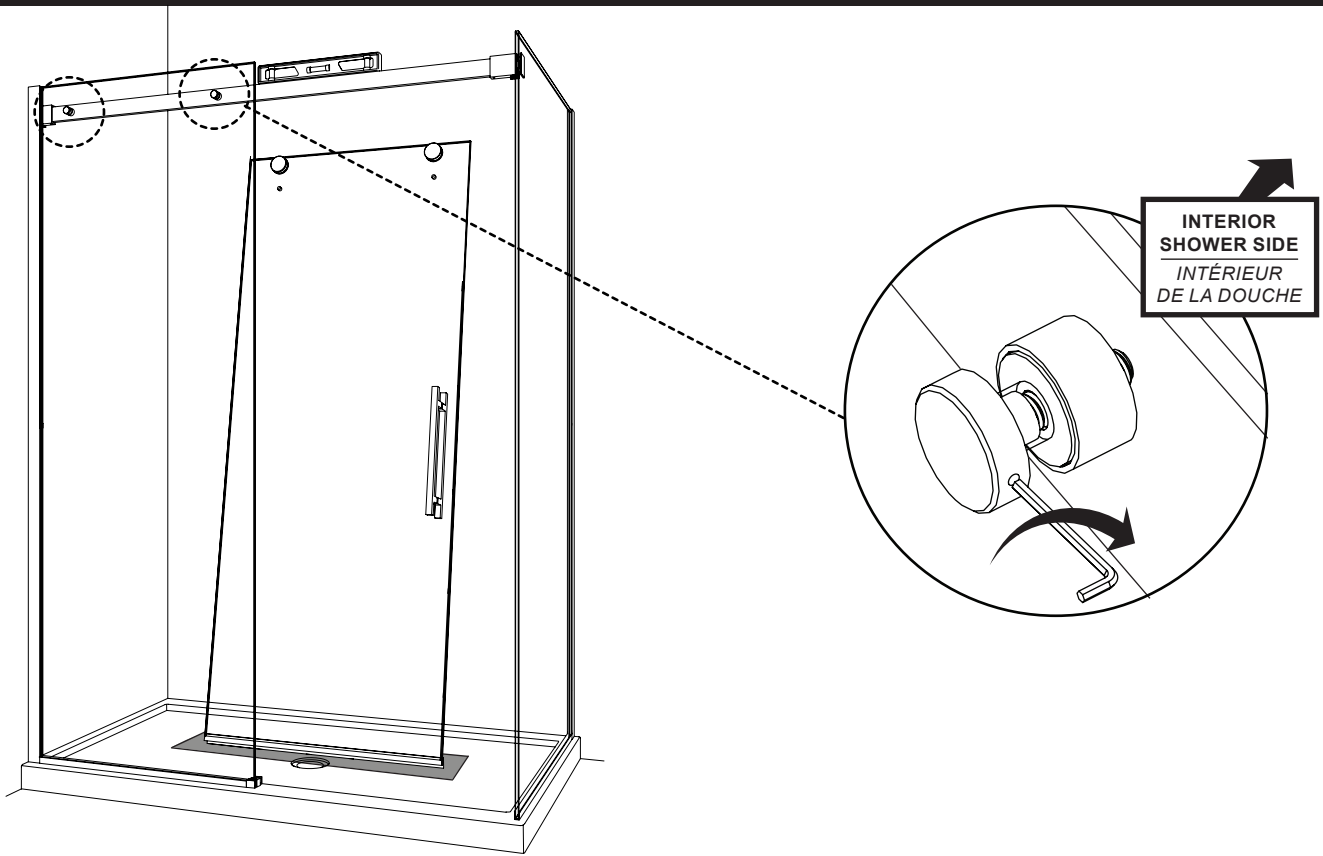

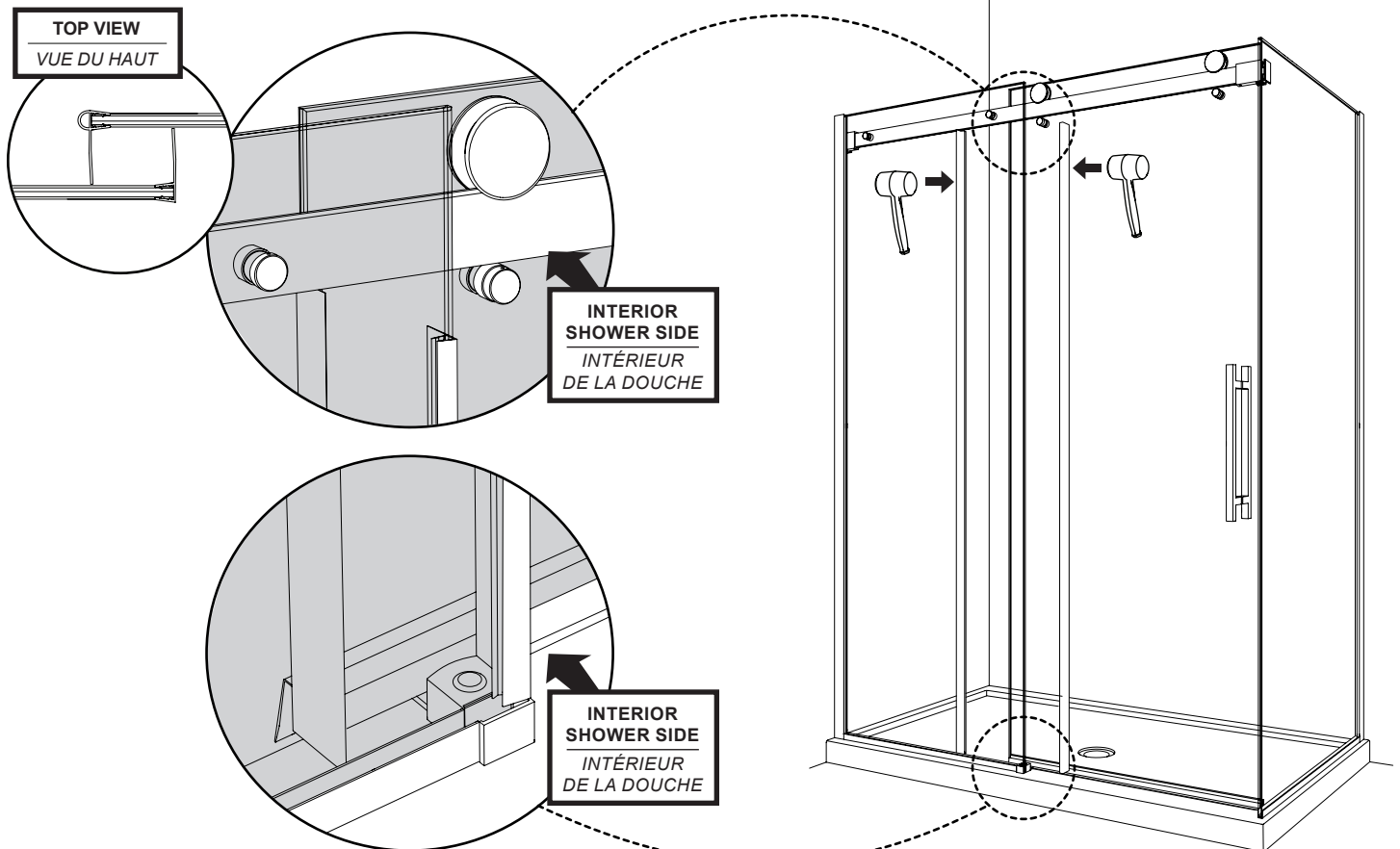
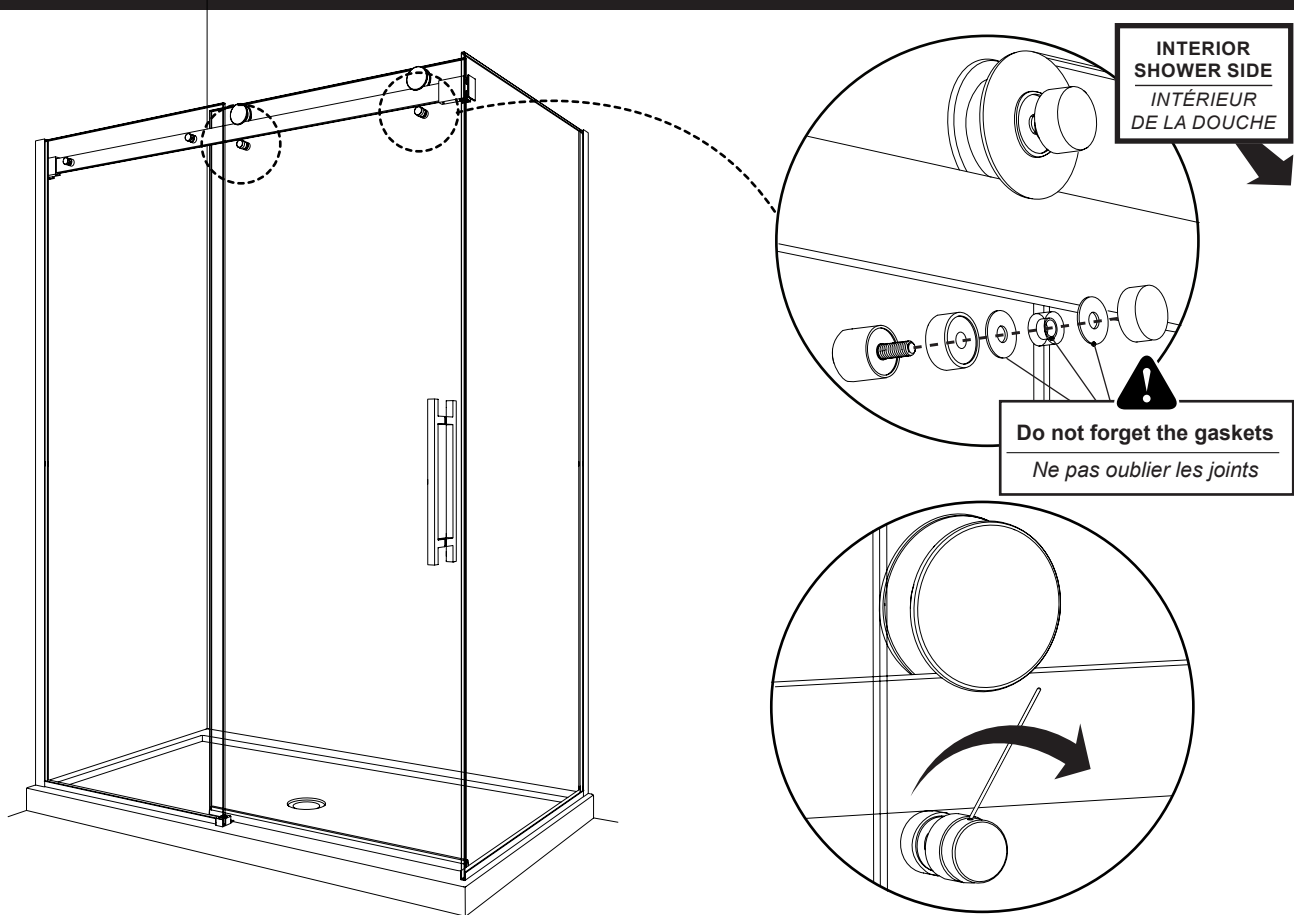

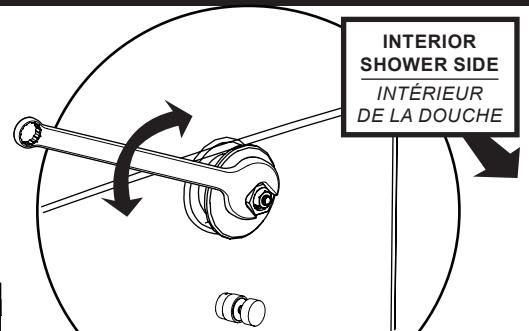
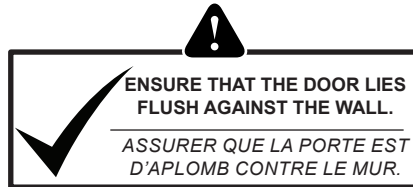

Level the door panel by rotating the eccentric nut to raise or lower the roller.

*Niveler le panneau de porte en tournant l'écrou excentrique pour lever ou baisser la roulette.*

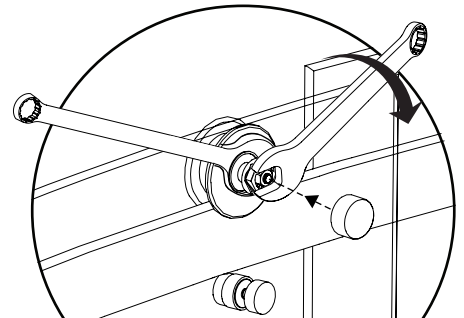

Hold eccentric nut in place with wrench while tightening the small nut and place the cap.

*Tenir l'écrou excentrique en place avec la clé tout en serrant le petit écrou et placer le capuchon.*

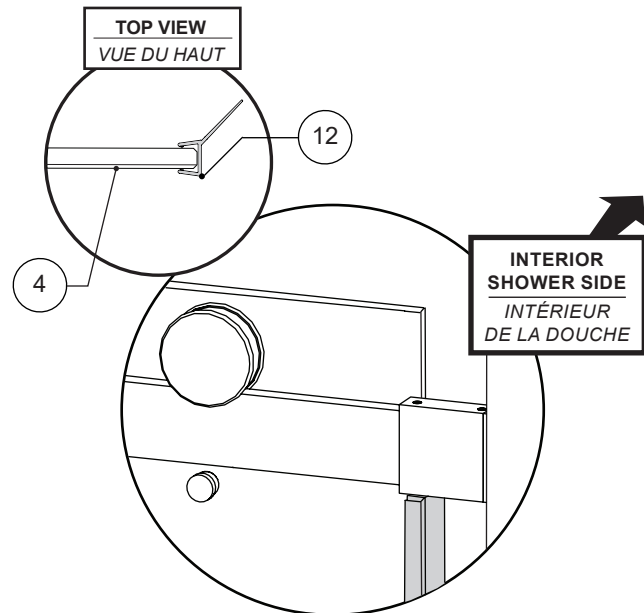
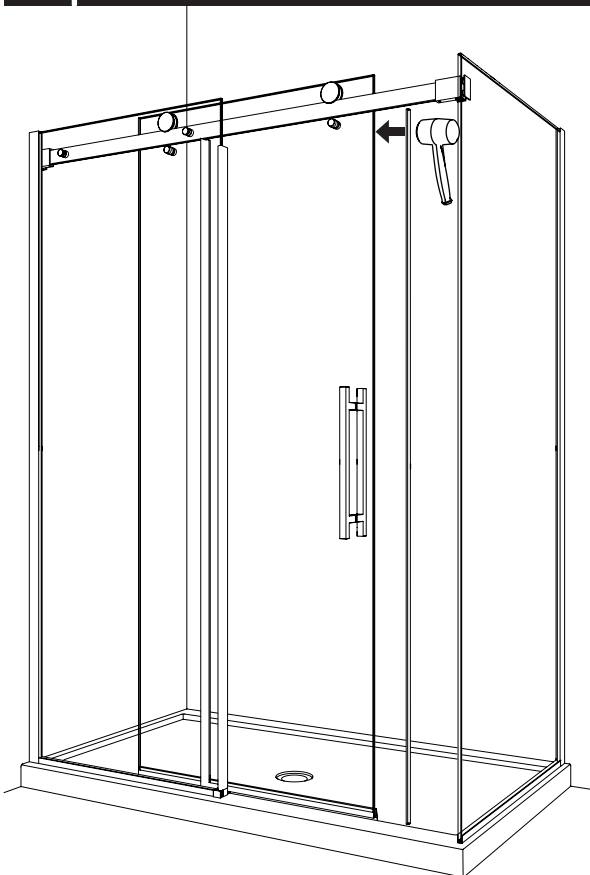

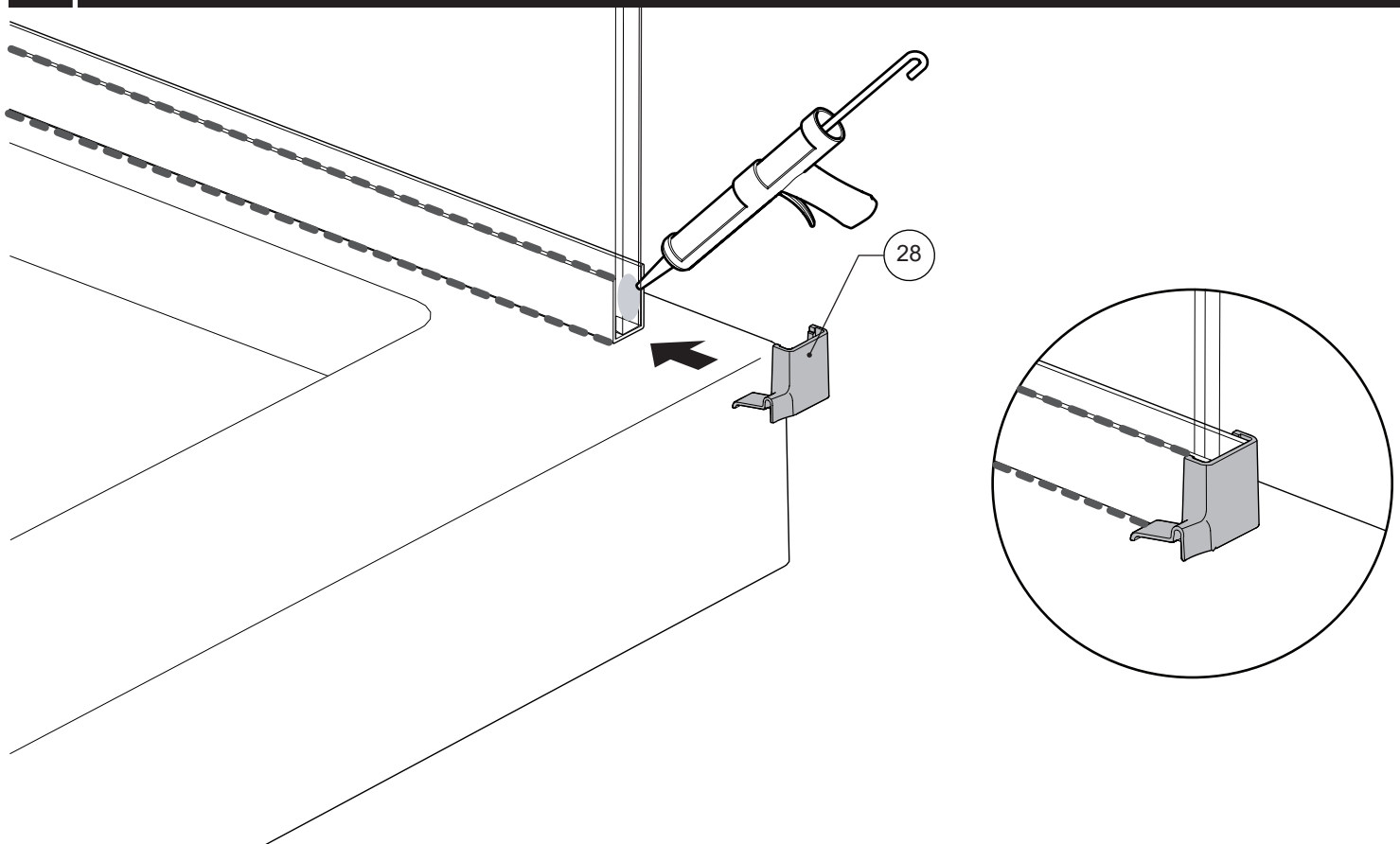
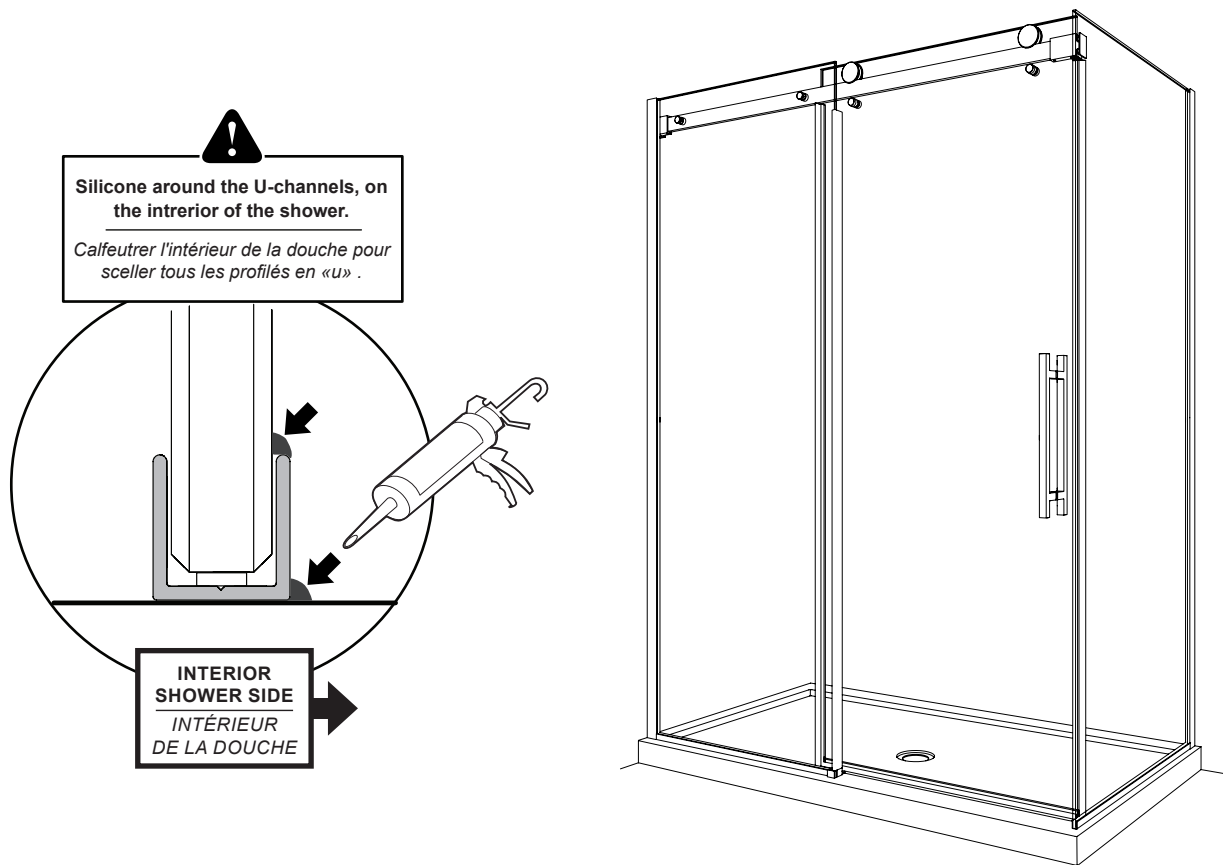





Place threshold between the wall and the bottom guide as indicated. Trim threshold if necessary **BEFORE** applying silicone.

Placer le seuil entre le mur et le guide inférieur comme indiqué. Couper le seuil si nécessaire **AVANT** d'appliquer du silicone.



Wipe the base with a clean cloth before installing the threshold.

Essuyer la base avec un chiffon propre avant d'installer le seuil.

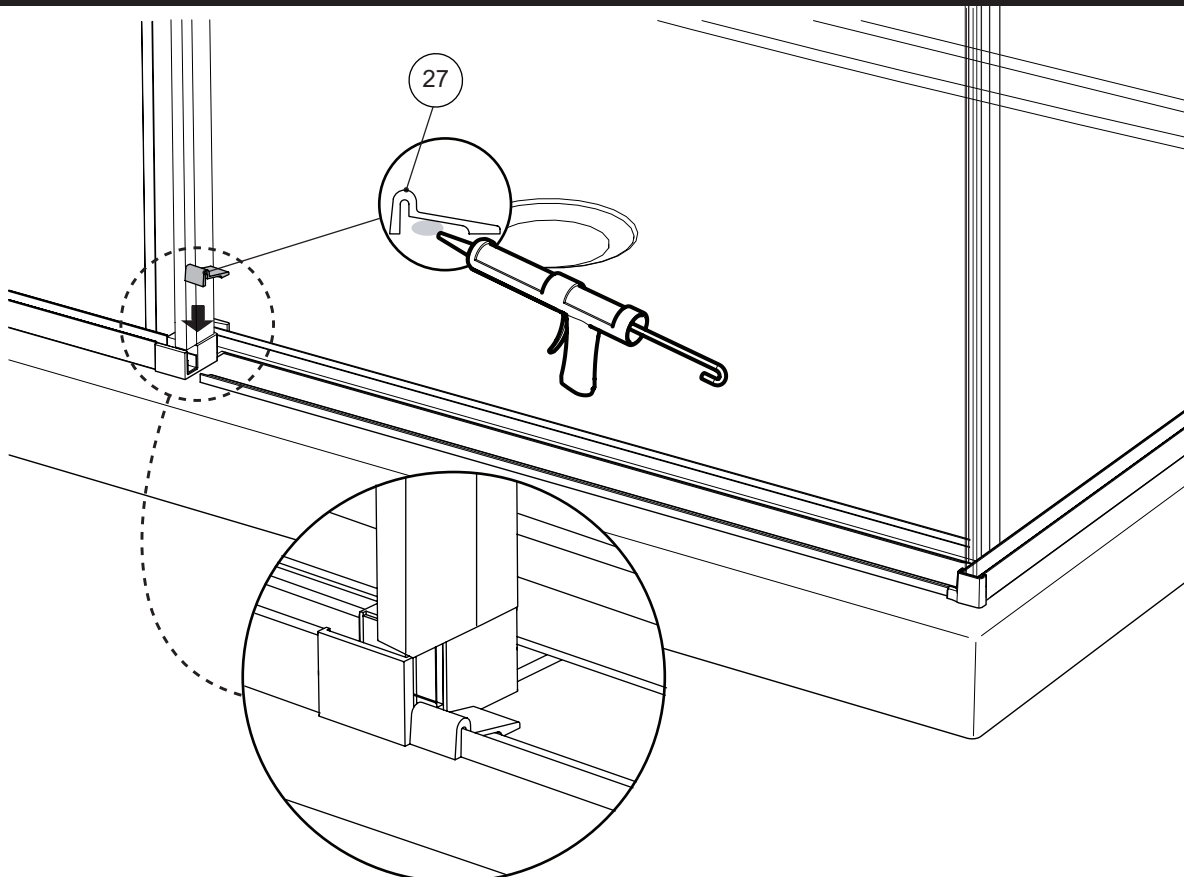
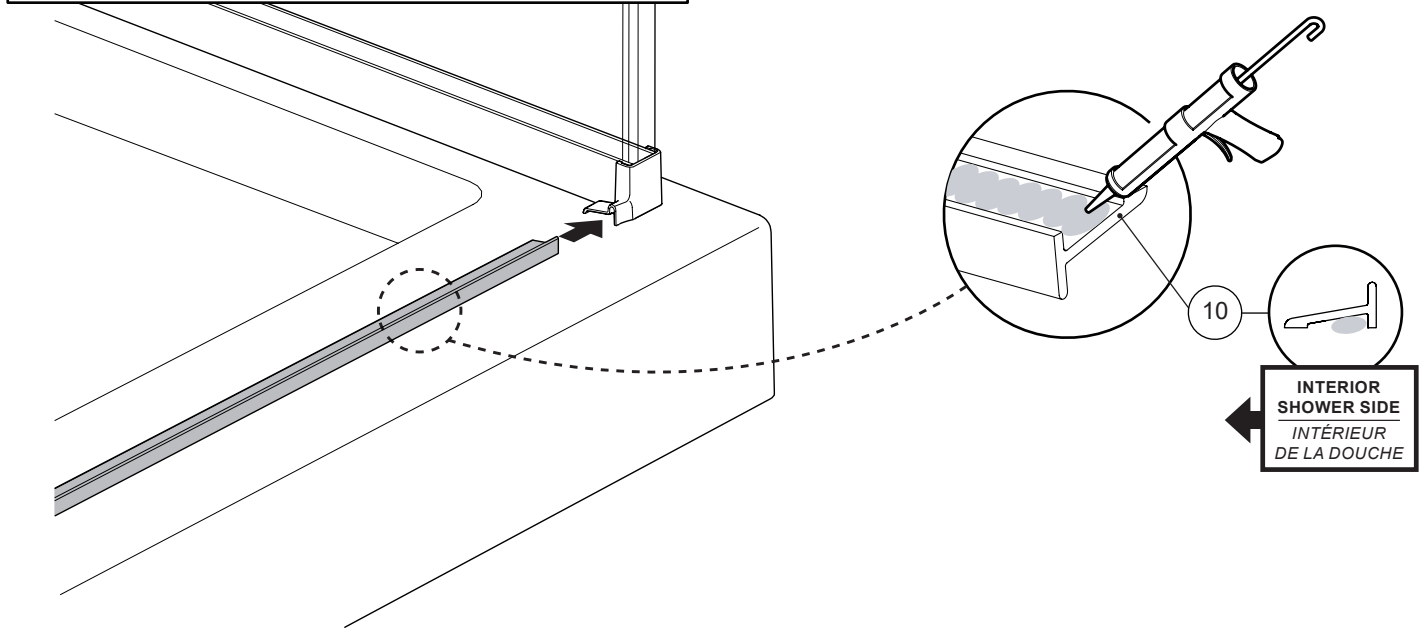

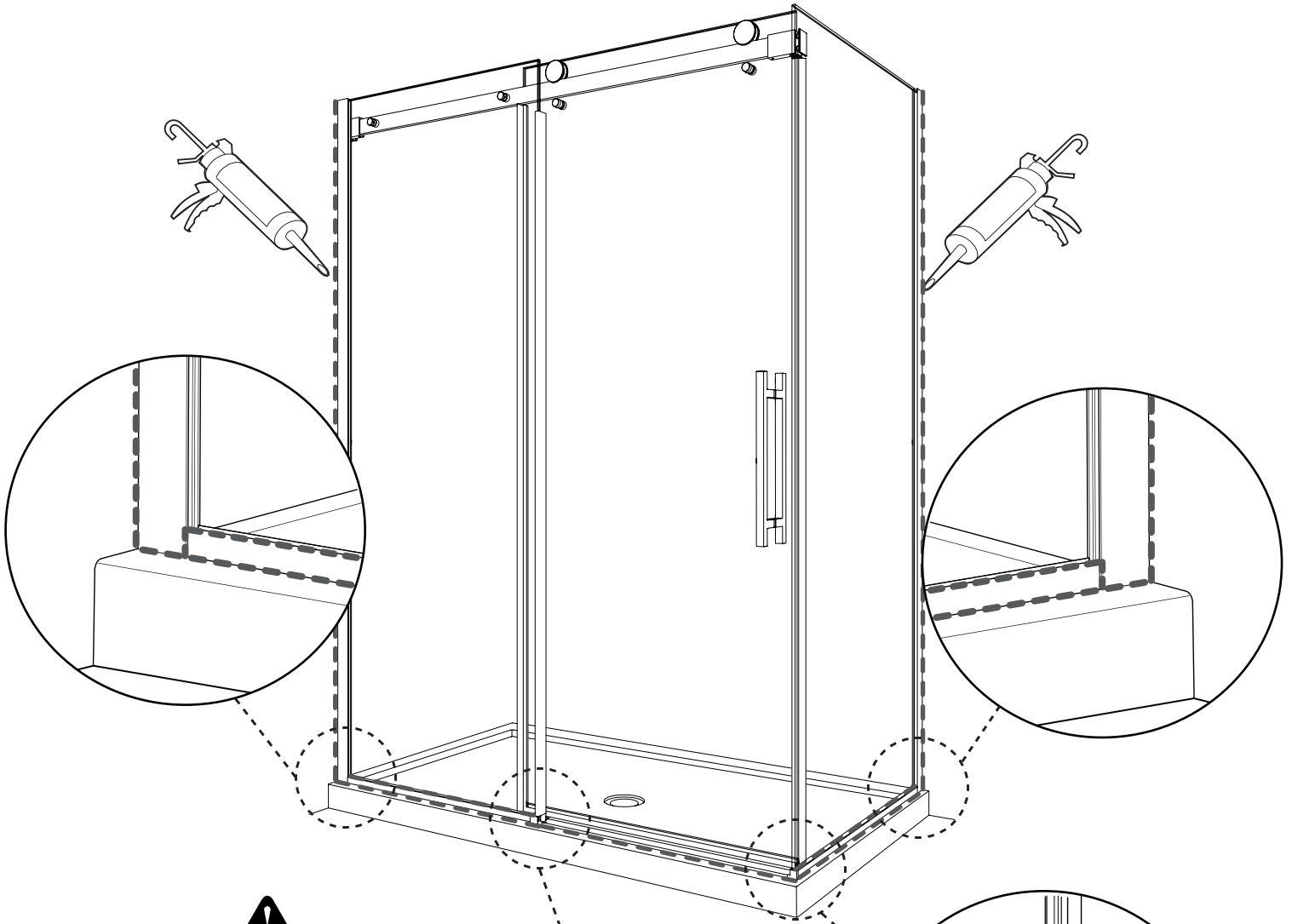

**!**  
**Silicone around the u-channels,  
 exterior of the shower.**  
*Calfeutrer l'extérieur de la douche pour  
 sceller tout les profilés «U» .*

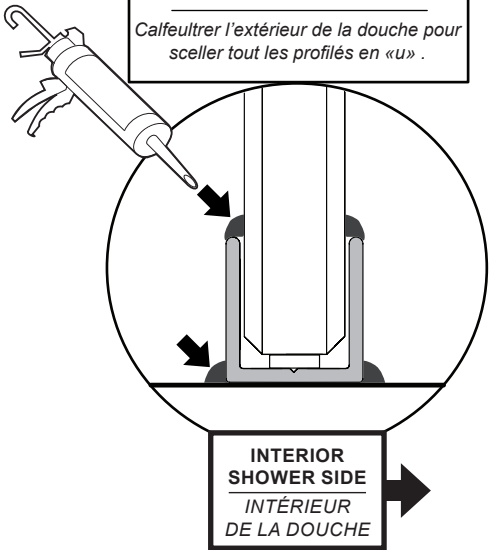

**INTERIOR  
 SHOWER SIDE**  
**INTÉRIEUR  
 DE LA DOUCHE** →

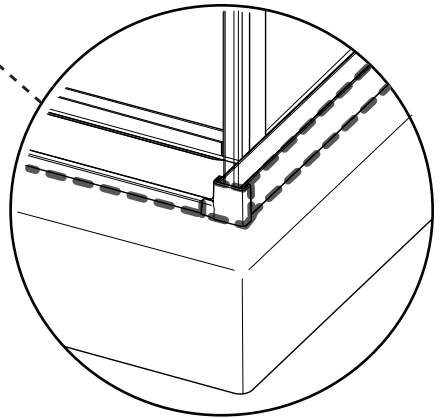
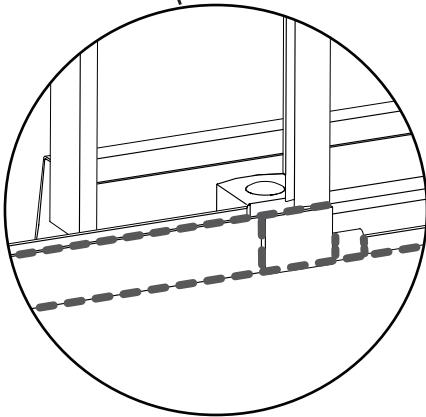

**24** HOURS  
HEURES