

INSTRUCTION MANUAL - GUIDE D'INSTALLATION

A003

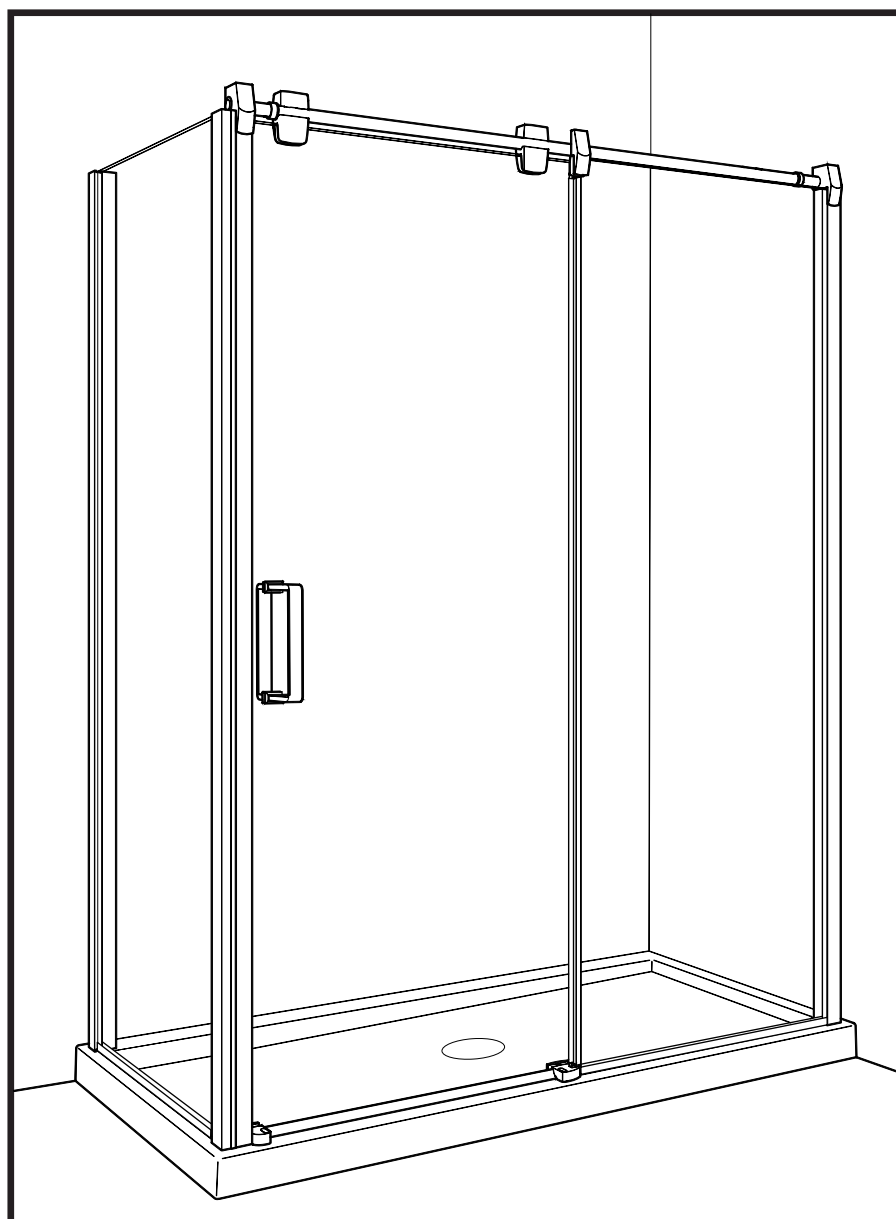

09 / 2018



2 PEOPLE REQUIRED
2 PERSONNES REQUIS

Please keep this manual and product code number for future reference and for ordering replacement parts if necessary.

Veillez conserver ce manuel et le code de produit pour des références futures, et au besoin, la commande de pièces de rechange.

GENERAL INSTRUCTIONS

- Read this manual carefully and completely before proceeding.
- It is recommended that you wear safety glasses at all times during the installation.



INSTRUCTIONS GÉNÉRALES

- Lire attentivement et complètement le manuel d'installation avant de procéder.
- Il est recommandé de porter des lunettes de sécurité en tout temps lors de l'installation.



INSTALLATION OVER CERAMIC TILES

- If your shower door is to be installed over ceramic tiles, the tiles should lay completely under the wall jamb.
- Silicone should be used to seal the gap where the ceramic tiles meet the fixed panel.

INSTALLATION SUR LES TUILES EN CÉRAMIQUE

- Si votre porte de douche doit être installée sur une bordure en céramique, le jambage doit reposer complètement sur cette dernière.
- Le calfeutrage doit être appliqué sur le côté extérieur de la douche où le panneau fixe rencontre la bordure en céramique.

NOTICE

- Caulking: no sealant is required inside the shower, unless otherwise stated.
- Some models are equipped with clear sealing gaskets.

NOTE

- Calfeutrage: aucun scellant n'est nécessaire à l'intérieur de la douche.
- Certains modèles sont dotés de joints d'étanchéité clairs.

CARE FOR YOUR SHOWER DOOR

- Never use scouring powder pads or sharp instruments on metal pieces or glass panels. An occasional wiping down with a mild soap diluted in water is all that is needed to keep the panels and aluminum parts looking new.
- We recommend wiping the glass panels with a squeegee after each use.

L'ENTRETIEN DE VOTRE DOUCHE

- Ne jamais utiliser de poudre ou de tampon à récurer, ni d'instrument tranchant sur les parties en métal ou en verre. De temps à autre, il suffit de nettoyer la porte avec une solution d'eau et un détergent doux pour conserver l'aspect neuf des panneaux de verre et du cadre en aluminium.
- Nous recommandons de passer une raclette de douche sur les panneaux de verre après chaque utilisation.

TOOLS REQUIRED / OUTILS REQUIS

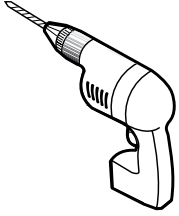

DRILL
PERCEUSE



1/4" & 1/8" DRILL BITS
MÈCHES 1/4" & 1/8"



PENCIL
CRAYON

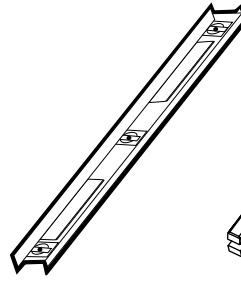

LEVEL
NIVEAU

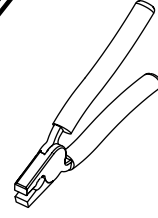

PLIERS
PINCES

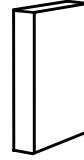

BLOCK
BLOC

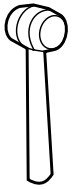

MALLET
MAILLET



SCREWDRIVER
TOURNEVIS

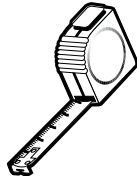

TAPE MEASURE
RUBAN À MESURER

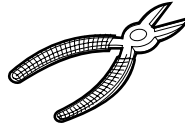

CUTTING PLIERS
PINCE COUPANTE



LONG NOSE LOCKING PLIERS (X2)
PINCE SERRE ÉTAU (X2)

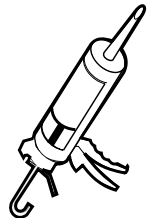

SILICONE
SCELLANT

* Use a 1/4" drill bit when drilling into ceramic tiles

* Utiliser une mèche de 1/4" pour percer des tuiles en céramique.

POSSIBLE CONFIGURATIONS / CONFIGURATIONS POSSIBLES

*

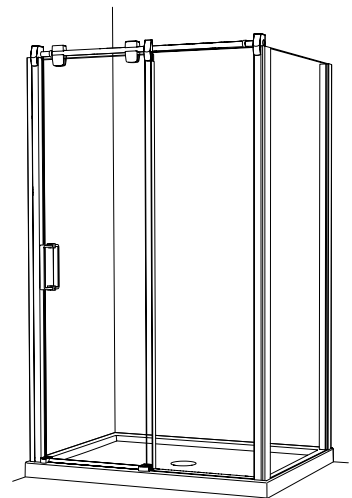
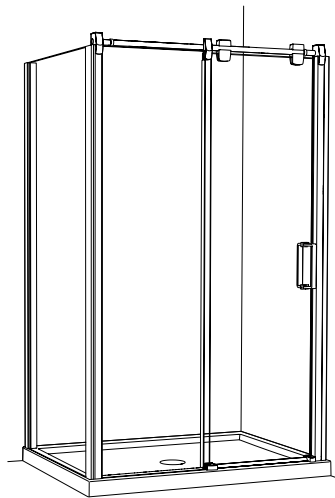
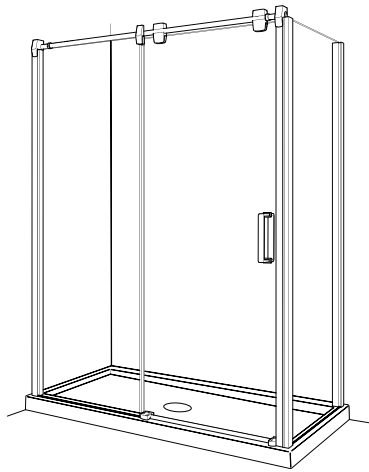
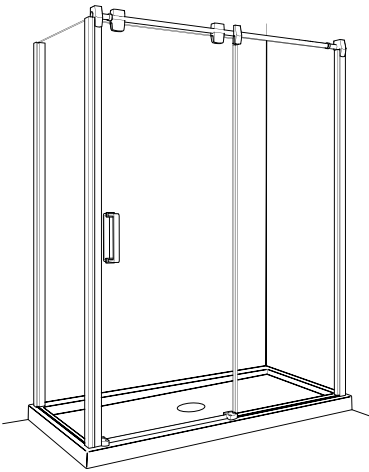

* This configuration illustrated in this manual.

* Cette configuration est illustrée dans ce manuel.

PARTS AND HARDWARE LISTING / LISTE DES PIÈCES ET QUINCAILLERIE

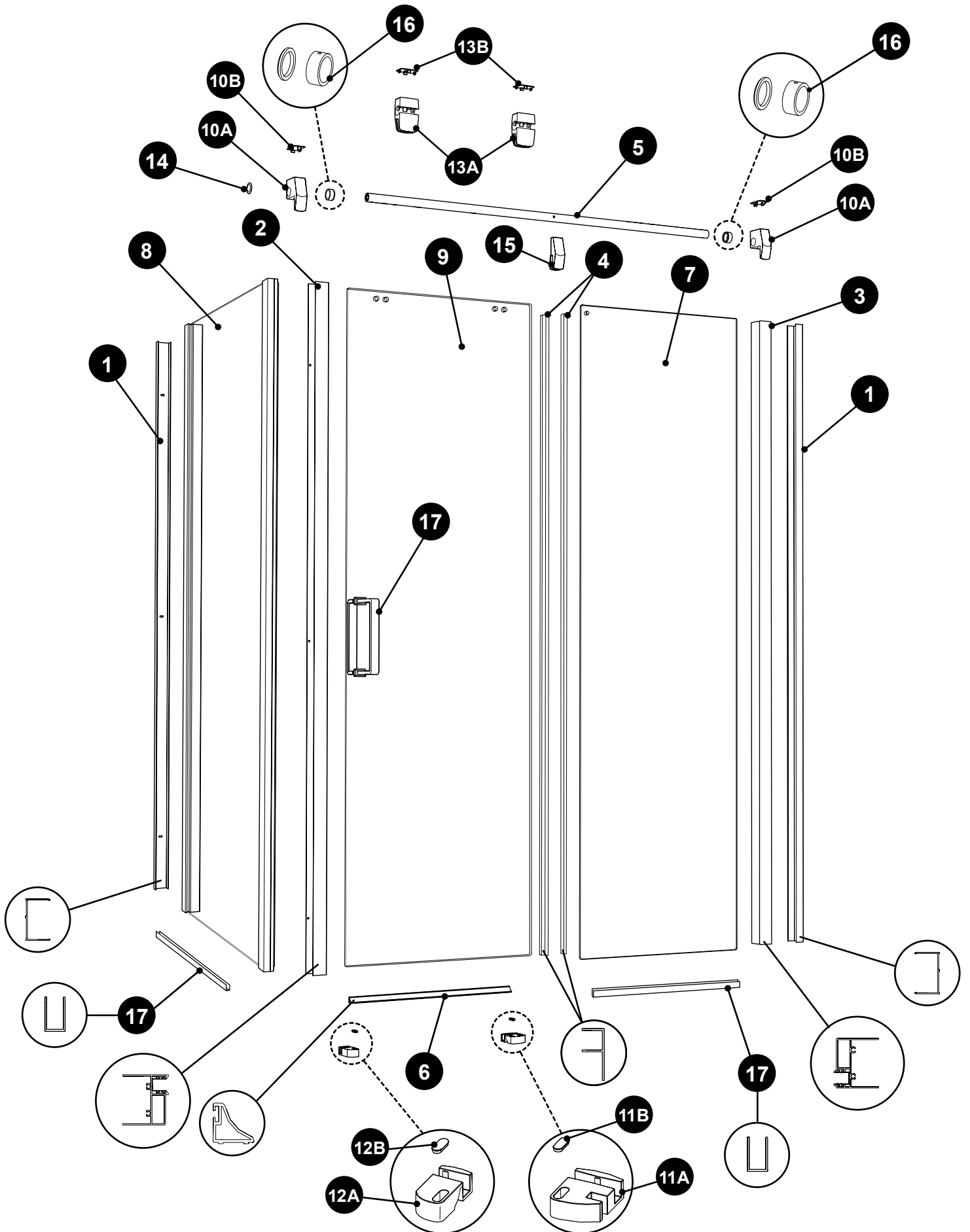

PARTS AND HARDWARE LISTING / LISTE DES PIÈCES ET QUINCAILLERIE

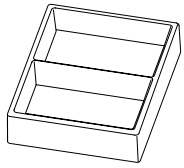

19



20



21



22

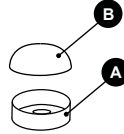

23



24

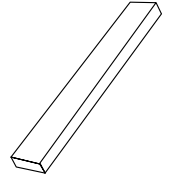

25

ITEM	PARTS AND HARDWARE / PIÈCES ET QUINCAILLERIE	QTY
1	WALL JAMB / JAMBAGE	2
2	DOOR PANEL EXPANDER / EXTENSEUR DE LA PORTE	1
3	FIXED PANEL EXPANDER / EXTENSEUR DU PANNEAU FIXE	1
4	MID GASKET / JOINT LATÉRAL	2
5	ROLLING RAIL BAR / BARRE DE ROULEMENT	1
6	ALUMINUM THRESHOLD / SEUIL DE RÉTENTION	1
7	FIXED PANEL / PANNEAU FIXE	1
8	RETURN PANEL / PANNEAU DE RETOUR	1
9	DOOR PANEL / PANNEAU DE PORTE	1
10A	RAIL SUPPORT / SUPPORT DE RAIL	2
10B	RAIL SUPPORT CAP / CAPUCHON DE SUPPORT DE RAIL	2
11A	DOOR GUIDE (L&R) / GUIDE DE PORTE (G&D)	1
11B	DOOR GUIDE CAP / CAPUCHON POUR GUIDE DE PORTE	1
12A	DOOR RECEIVER (L&R) / RÉCEPTEUR DE PORTE (G&D)	1
12B	DOOR RECEIVER CAP / CAPUCHON POUR RÉCEPTEUR DE PORTE	1
13A	ROLLERS / ROULETTES	2
13B	ROLLER CAP / CAPUCHON POUR ROULEMENT	1
14	RAIL END CAP / CAPUCHON DE RAIL	1
15	FIXED PANEL SUPPORT / SUPPORT DE PANNEAU FIXE	1
16	STOPPER / BUTOIR	2
17	U-CHANNEL / PROFILÉ EN «U»	2
18	HANDLE / POIGNÉE	1
19	ANCHORING BLOCK / BLOC D'ANCRAGE	1
20	WALL PLUG / CHEVILLE	6
21	PAN SELF-DRILLING SCREW ST4.2X30 / VIS PAN AUTO-PERCANTE ST4.2X30	8
22	PAN SELF-DRILLING SCREW ST4.2 X10 / VIS PAN AUTO-PERCANTE ST4.2 X10	9
23A	BACK SCREW CAP / L'ARRIÈRE DU CAPUCHON COUVRE-VIS	9
23B	SCREW CAPS / CAPUCHON COUVRE-VIS	9
24	RAIL BAR SUPPORT AND EXPANDER SCREW ST4X50 / VIS POUR SUPPORT DE RAIL ET EXTENSEUR ST4X50	4
25	CLEAR SETTING BLOCK / BLOC À NIVEAU TRANSPARENT	8

MARK THE PLACEMENT AREA ON THE BASE / MARQUER LA ZONE DE POSITIONNEMENT SUR LA BASE

MODEL MODÈLE	DIM A = DOOR AND FIXED PANEL OPENING <i>DIM A = OUVERTURE POUR LE PANNEAU FIXE ET LA PORTE</i>		DIM B = RETURN PANEL OPENING <i>DIM B = OUVERTURE DU CÔTÉ POUR PANNEAU DE RETOUR</i>	
	MIN	MAX	MIN	MAX
4832	45 3/8" / 1153 mm	45 7/8" / 1165 mm	28 7/8" / 733 mm	29 3/8" / 746 mm
4836	45 3/8" / 1153 mm	45 7/8" / 1165 mm	32 7/8" / 835 mm	33 3/8" / 848 mm
4842	45 3/8" / 1153 mm	45 7/8" / 1165 mm	38 7/8" / 987 mm	39 3/8" / 1000 mm
4848	45 3/8" / 1153 mm	45 7/8" / 1165 mm	44 7/8" / 1139 mm	45 3/8" / 1153 mm
6032	57 3/8" / 1457 mm	57 7/8" / 1470 mm	28 7/8" / 733 mm	29 3/8" / 746 mm
6036	57 3/8" / 1457 mm	57 7/8" / 1470 mm	32 7/8" / 835 mm	33 3/8" / 848 mm
6042	57 3/8" / 1457 mm	57 7/8" / 1470 mm	38 7/8" / 987 mm	39 3/8" / 1000 mm
6048	57 3/8" / 1457 mm	57 7/8" / 1470 mm	44 7/8" / 1139 mm	45 3/8" / 1153 mm
7232	69 3/8" / 1762 mm	69 7/8" / 1775 mm	28 7/8" / 733 mm	29 3/8" / 746 mm
7236	69 3/8" / 1762 mm	69 7/8" / 1775 mm	32 7/8" / 835 mm	33 3/8" / 848 mm
7242	69 3/8" / 1762 mm	69 7/8" / 1775 mm	38 7/8" / 987 mm	39 3/8" / 1000 mm
7248	69 3/8" / 1762 mm	69 7/8" / 1775 mm	44 7/8" / 1139 mm	45 3/8" / 1153 mm

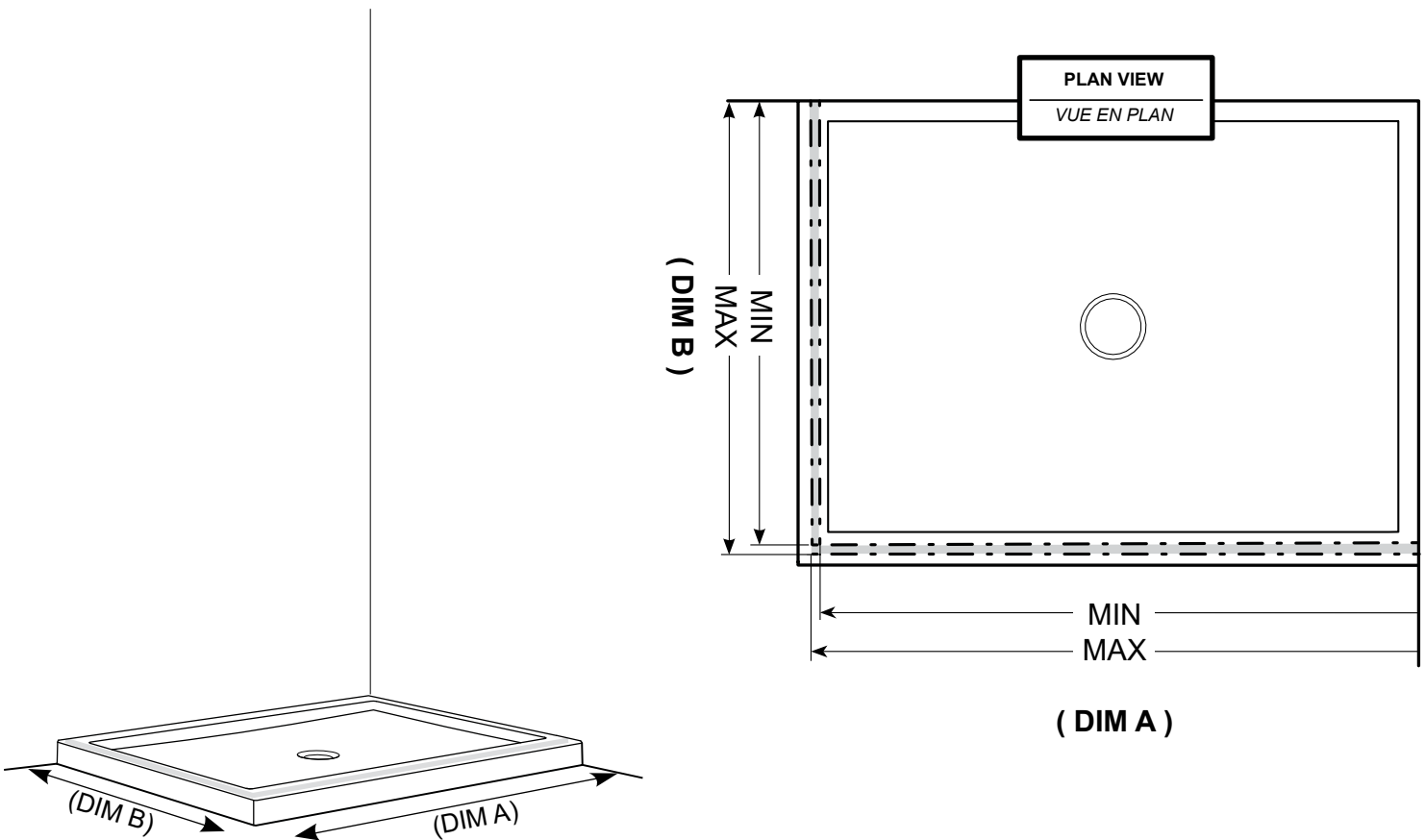

"Dim A" represents the distance from the wall to the return panel position on the base.
 "Dim B" represents the distance from the wall to the door and fixed panel position on the base.
 "Dim A" représente la distance du mur fini au position du panneau de retour sur la base.
 "Dim B" représente la distance du mur fini au position du panneau fixe et la porte sur la base.

MARK THE CENTER LINE / MARQUER LA LIGNE DU CENTRE

CENTERLINE
LIGNE DU CENTRE

**INTERIOR
SHOWER SIDE**
INTÉRIEUR
DE LA DOUCHE

 **THE CENTERLINE MUST BE WITHIN
THE PLACEMENT ZONE.**
LA LIGNE CENTRALE DOIT ÊTRE DANS
LA ZONE DE POSITIONNEMENT.

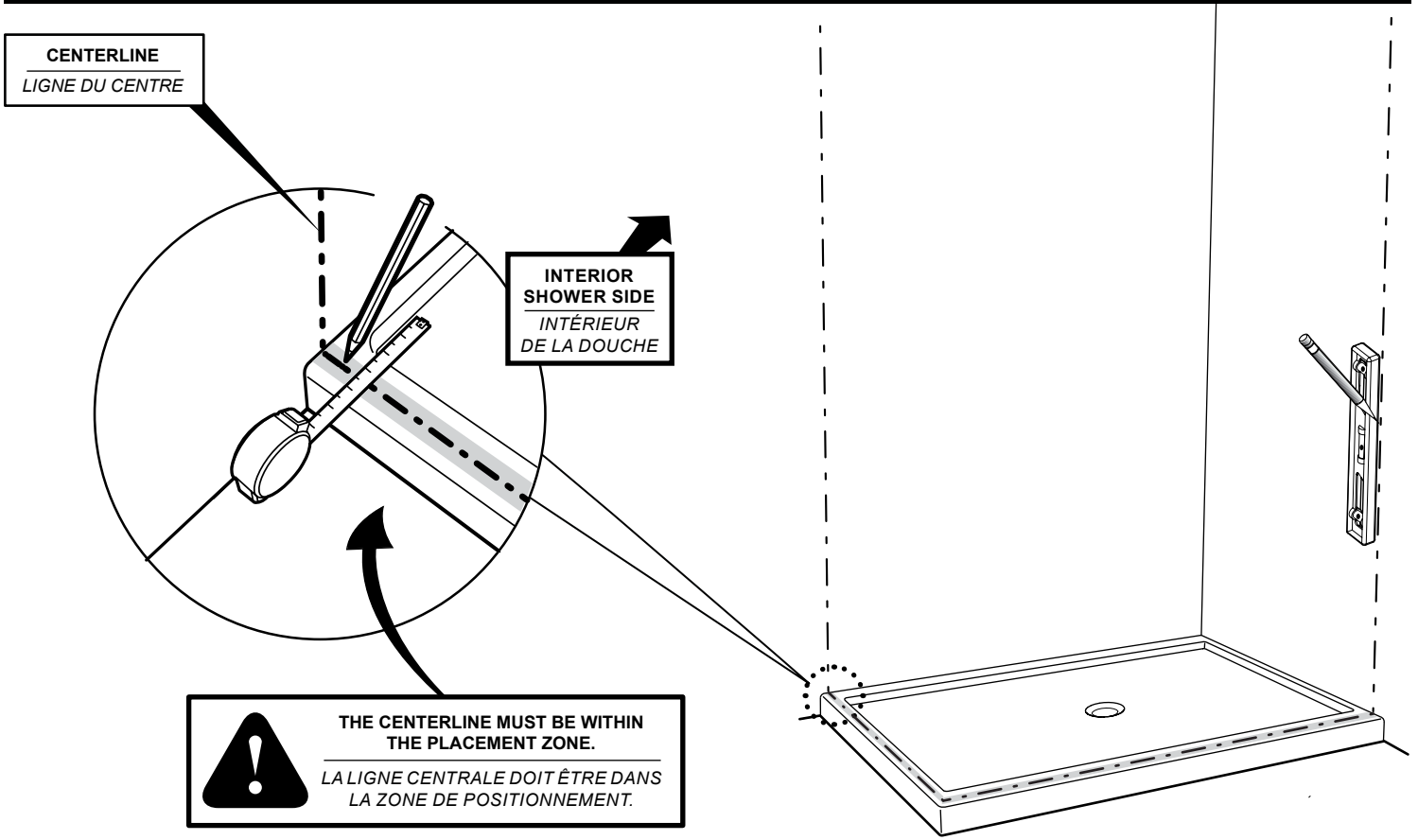

INSTALL THE WALL PLUGS / INSTALLER LES CHEVILLES

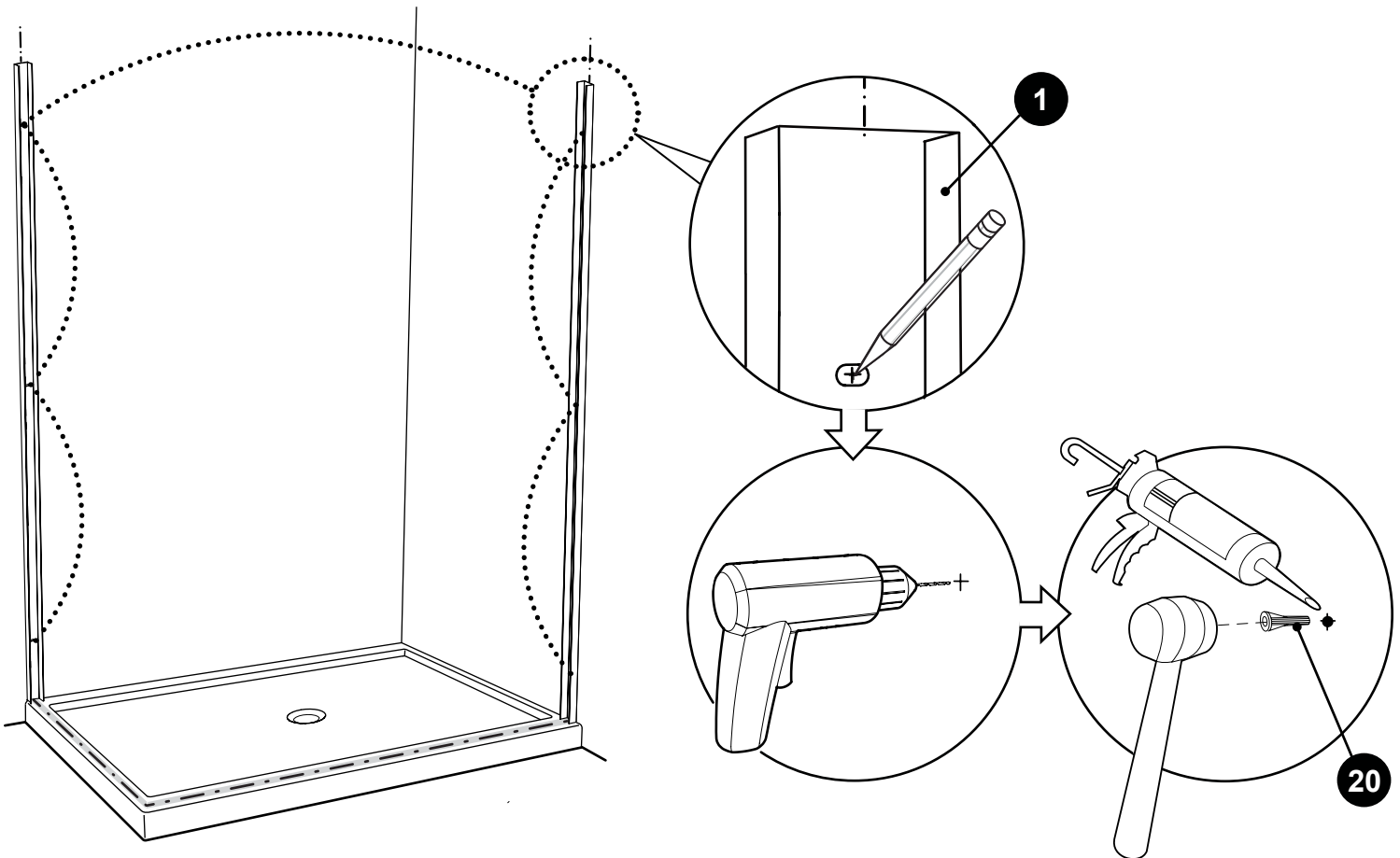

INSTALL THE WALL JAMBS / INSTALLER LES JAMBAGES

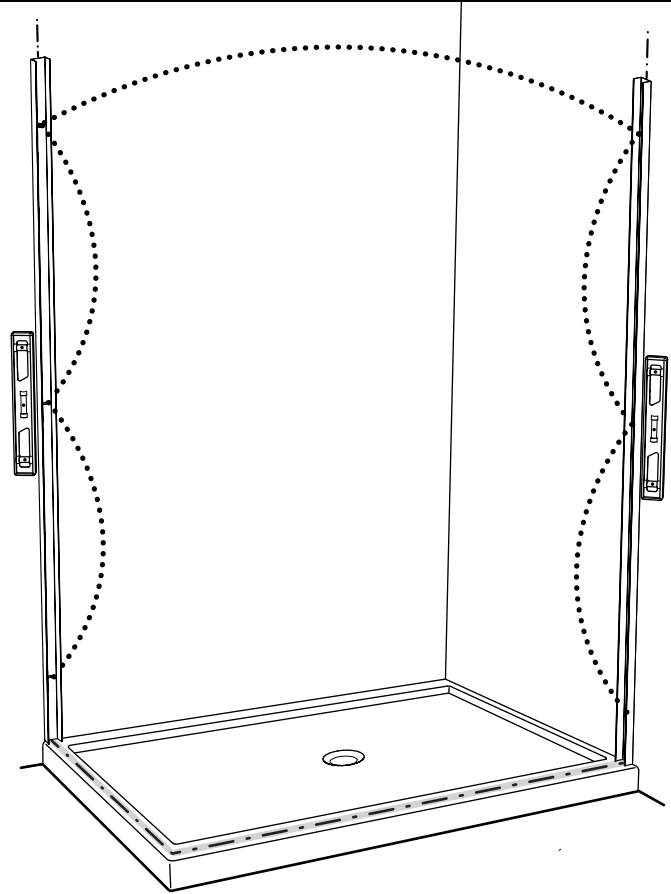
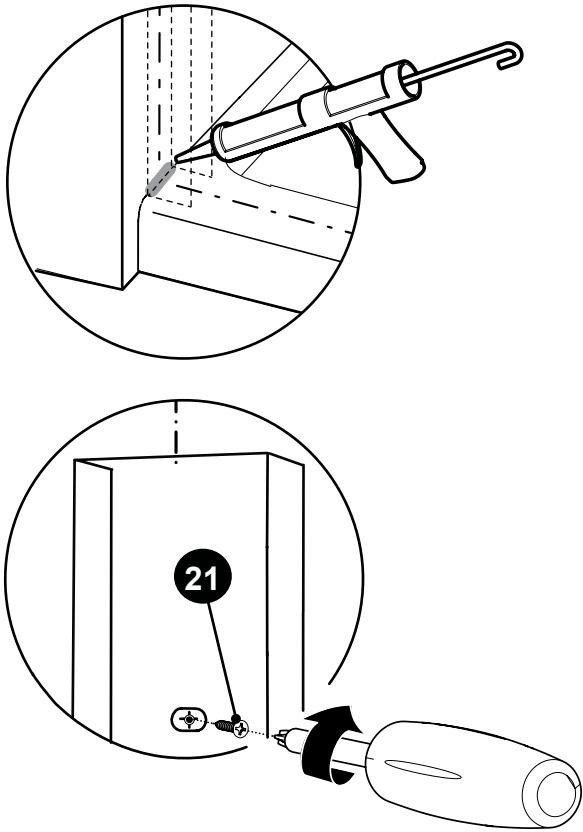

**PUT THE RAIL SUPPORTS ONTO THE RAIL BAR
METTRE LES SUPPORTS DE RAIL SUR LA BARRE DE ROULEMENT**

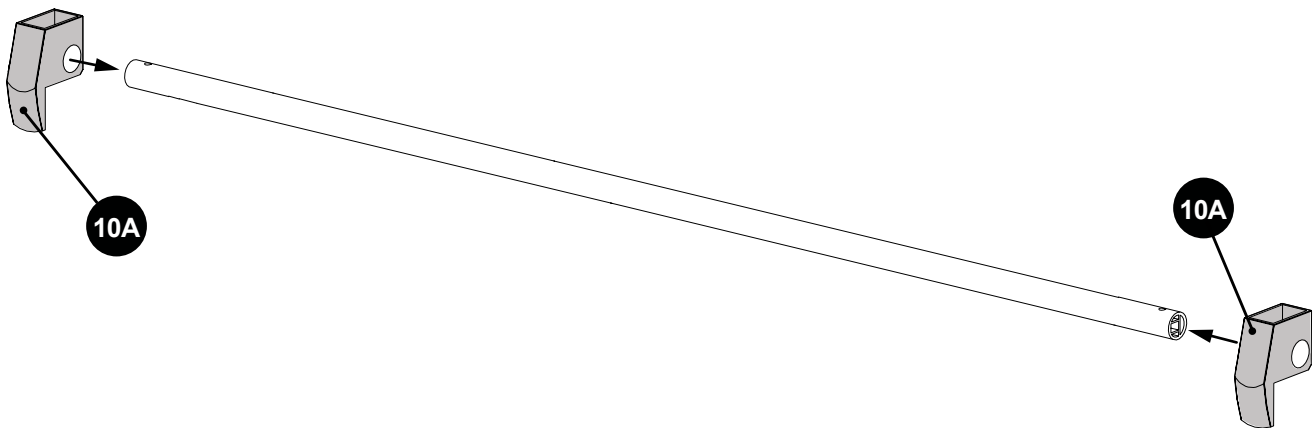

TEMPORARILY INSTALL THE RETURN PANEL / INSTALLER LE PANNEAU DE RETOUR TEMPORAIREMENT

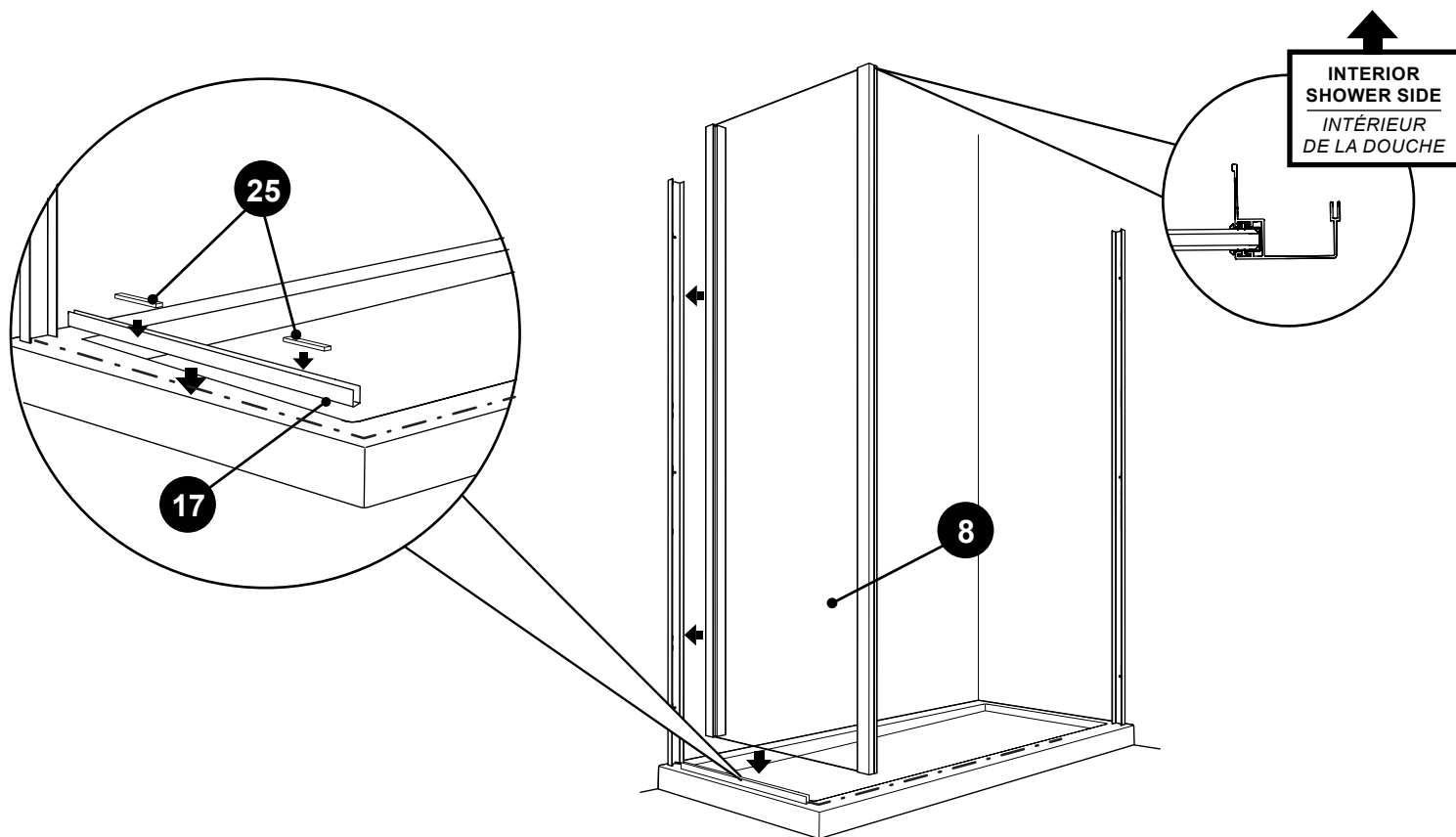

**INTERIOR
SHOWER SIDE**
INTÉRIEUR
DE LA DOUCHE

LEVEL THE PANEL AND CLAMP WITH PLIERS / NIVELER LE PANNEAU ET SERRER AVEC UNE PINCE SERRE ÉTAU

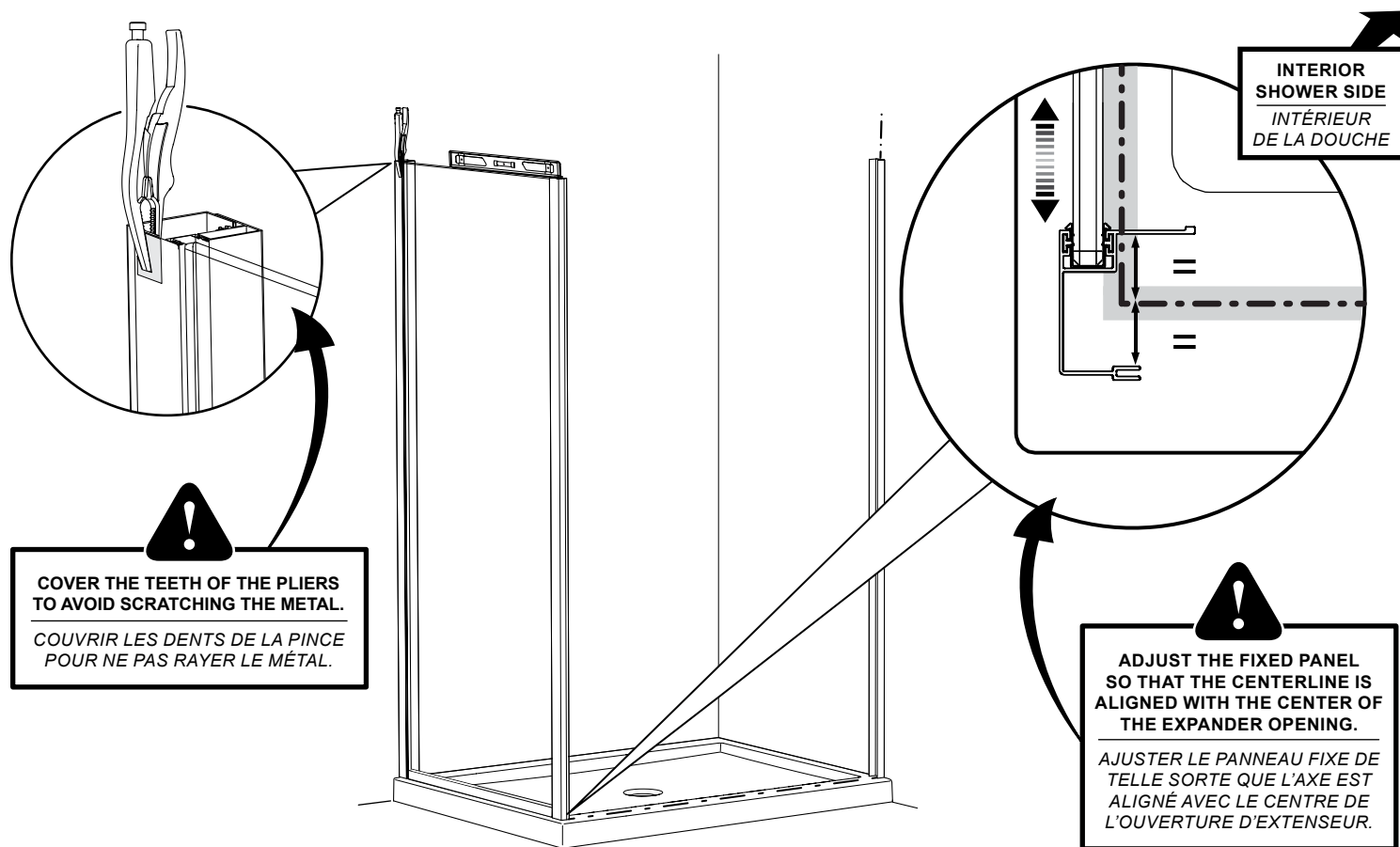

**INTERIOR
SHOWER SIDE**
INTÉRIEUR
DE LA DOUCHE

**COVER THE TEETH OF THE PLIERS
TO AVOID SCRATCHING THE METAL.**
COUVRIR LES DENTS DE LA PINCE
POUR NE PAS RAYER LE MÉTAL.

**ADJUST THE FIXED PANEL
SO THAT THE CENTERLINE IS
ALIGNED WITH THE CENTER OF
THE EXPANDER OPENING.**
AJUSTER LE PANNEAU FIXE DE
TELLE SORTE QUE L'AXE EST
ALIGNÉ AVEC LE CENTRE DE
L'OUVERTURE D'EXTENSEUR.

INSTALL THE DOOR PANEL EXPANDER / INSTALLER L'EXTENSEUR DU PANNEAU DE PORTE

PERFORM THIS STEP ONLY IF THE DOOR IS CLOSING ON THE RETURN PANEL SIDE, AS SHOWN BELOW. IF THE DOOR IS CLOSING AGAINST THE WALL, INSTALL THE DOOR EXPANDER TO THE WALL JAMB, BUT DO NOT SECURE IT. CLAMP WITH LOCKING PLIERS INSTEAD.

EFFECTUER CETTE ÉTAPE UNIQUEMENT SI LA PORTE SE REFERME SUR LE CÔTÉ DU PANNEAU RETOUR. SI LA PORTE SE FERME CONTRE LE MUR, INSTALLER L'EXTENSEUR DE LA PORTE SUR LE JAMBAGE MURALE, MAIS NE PAS LE SÉCURISER. RETENIR AVEC LA PINCE-ÉTAU.

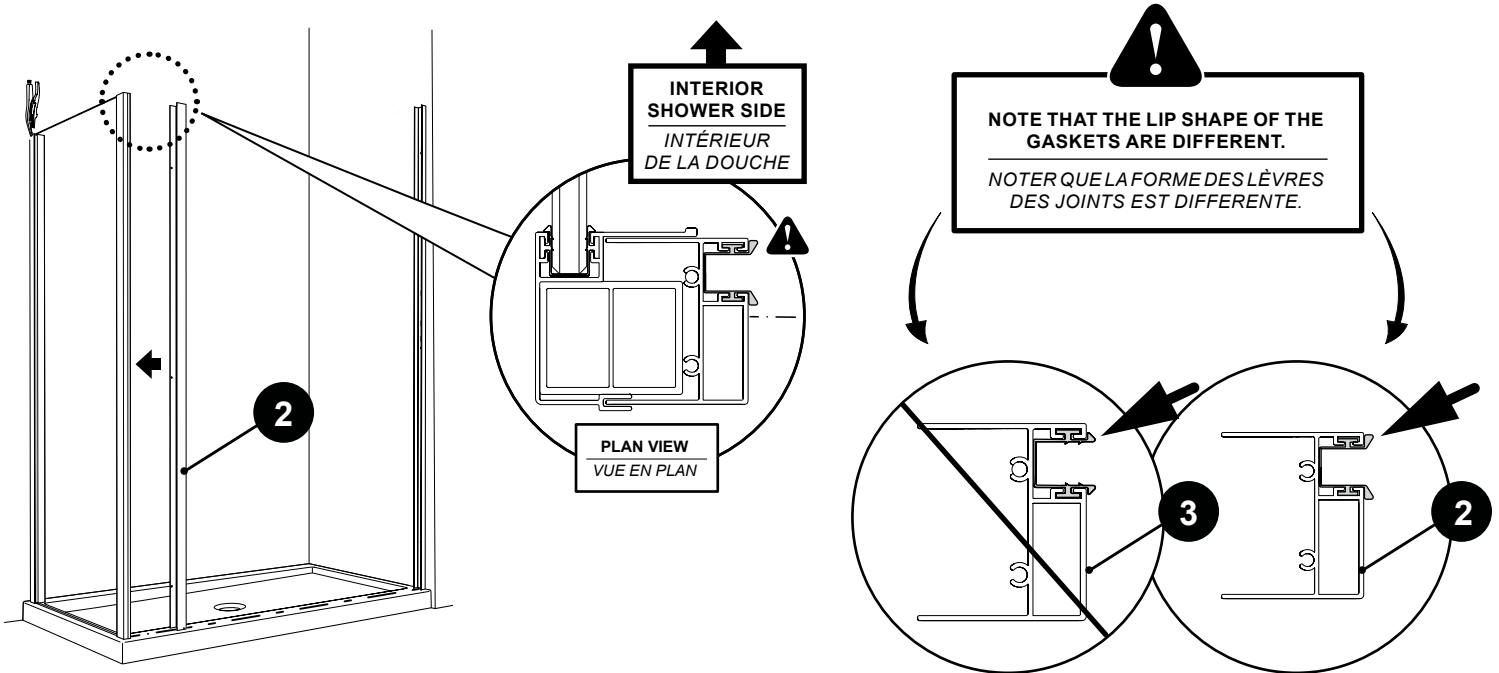

INSTALL THE EXPANDER TO THE FIXED PANEL / INSTALLER L'EXTENSEUR SUR LE PANNEAU FIXE

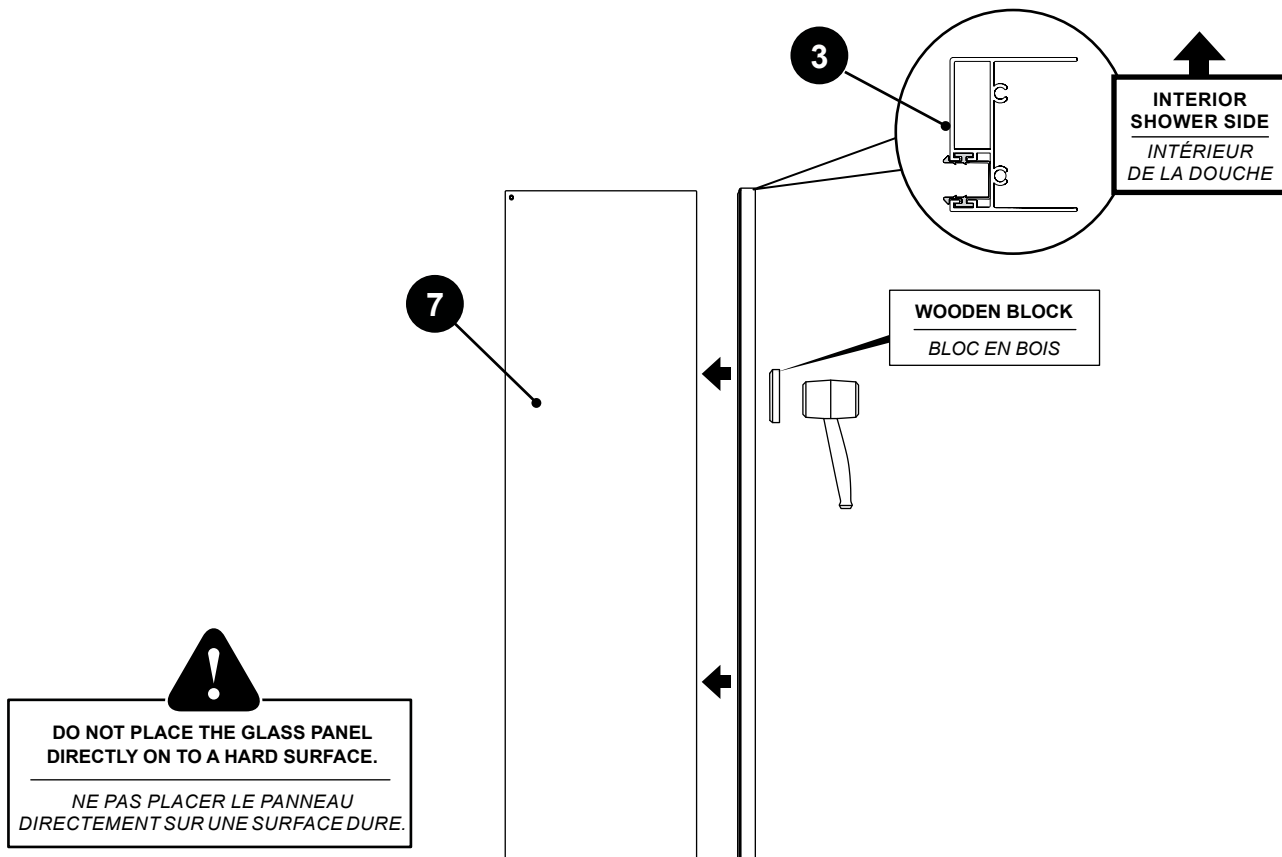

TEMPORARILY INSTALL THE FIXED PANEL / INSTALLER LE PANNEAU FIXE TEMPORAIREMENT

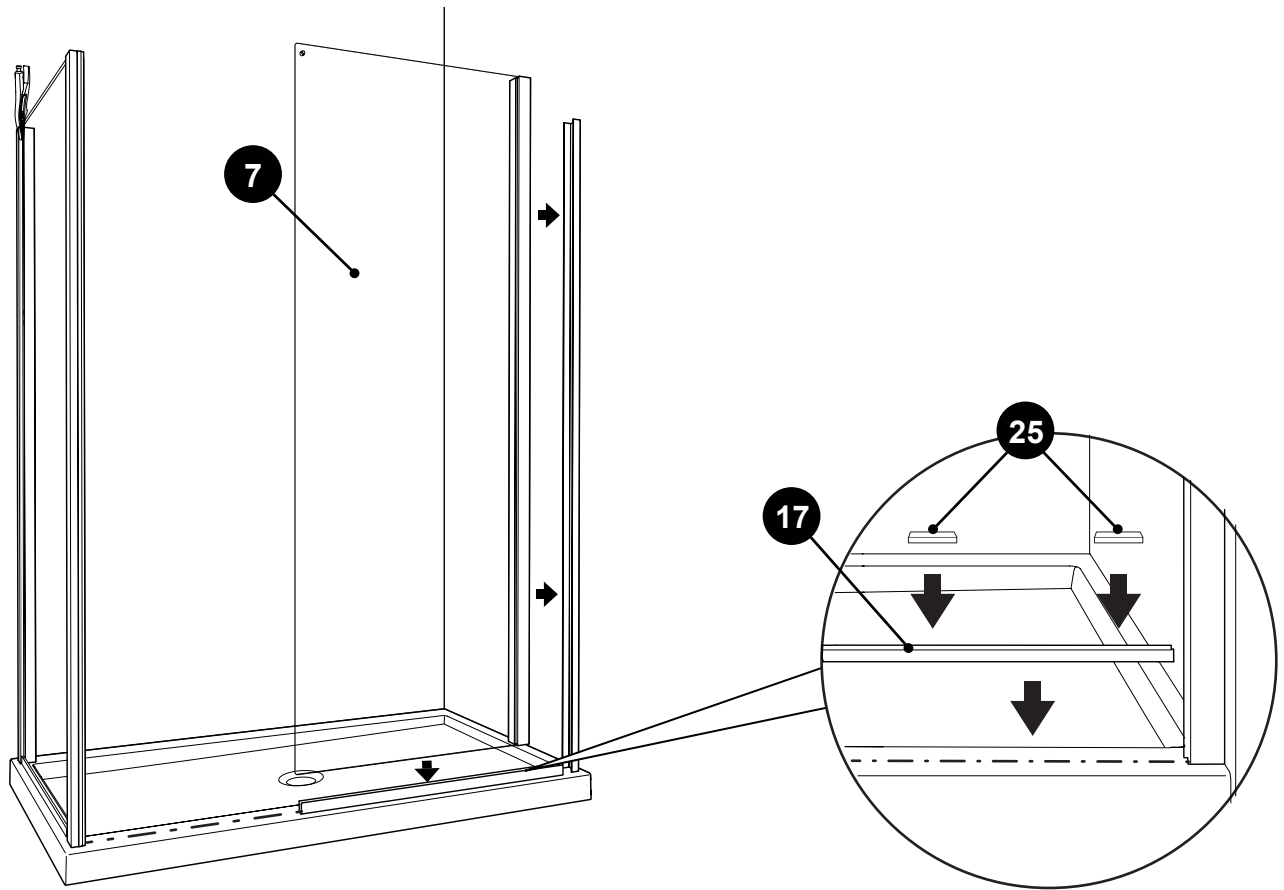

TEMPORARILY INSTALL THE RAIL BAR / INSTALLER LA BARRE DE ROULEMENT TEMPORAIREMENT

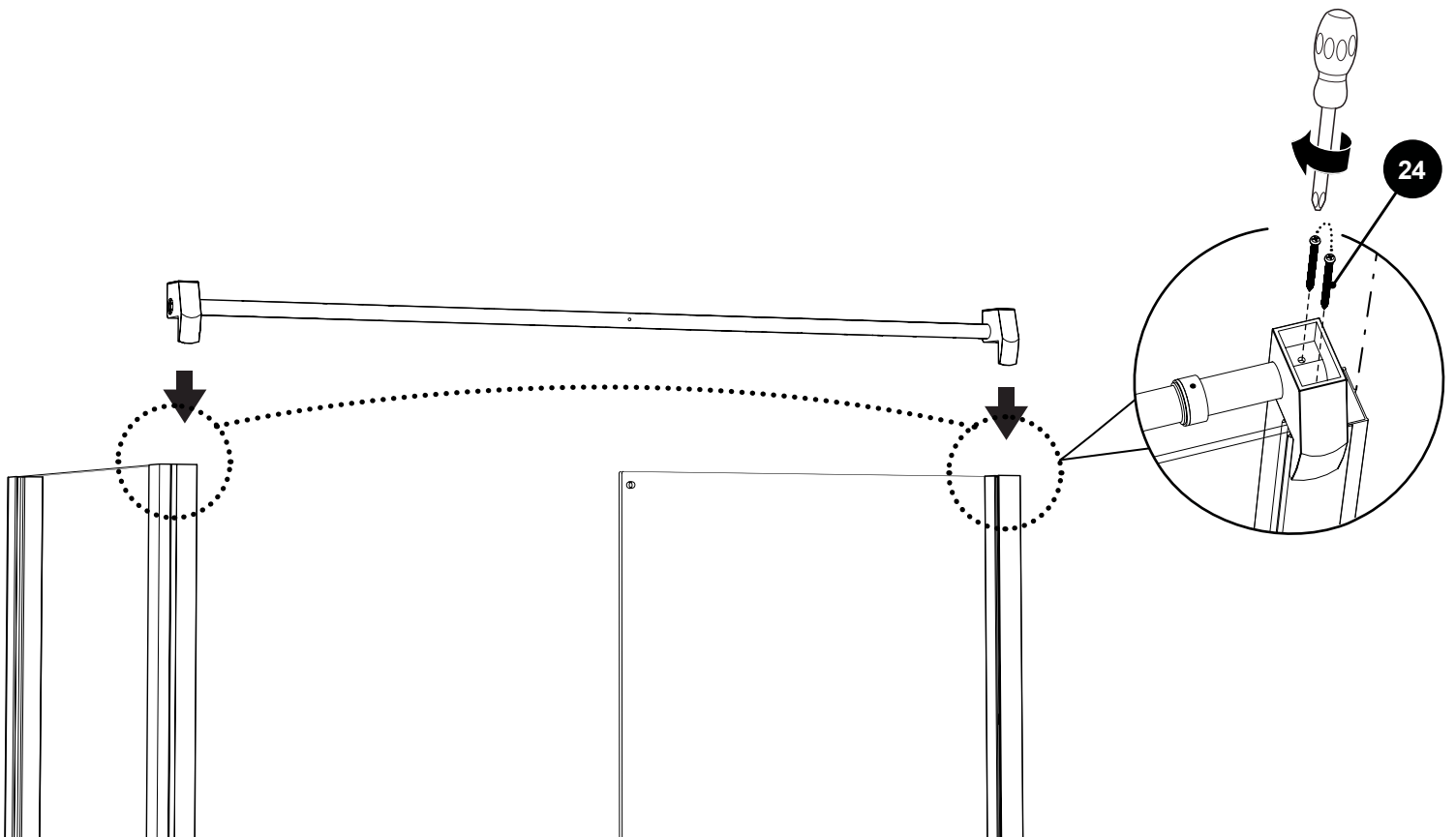

LEVEL AND ADJUST / NIVELER ET AJUSTER

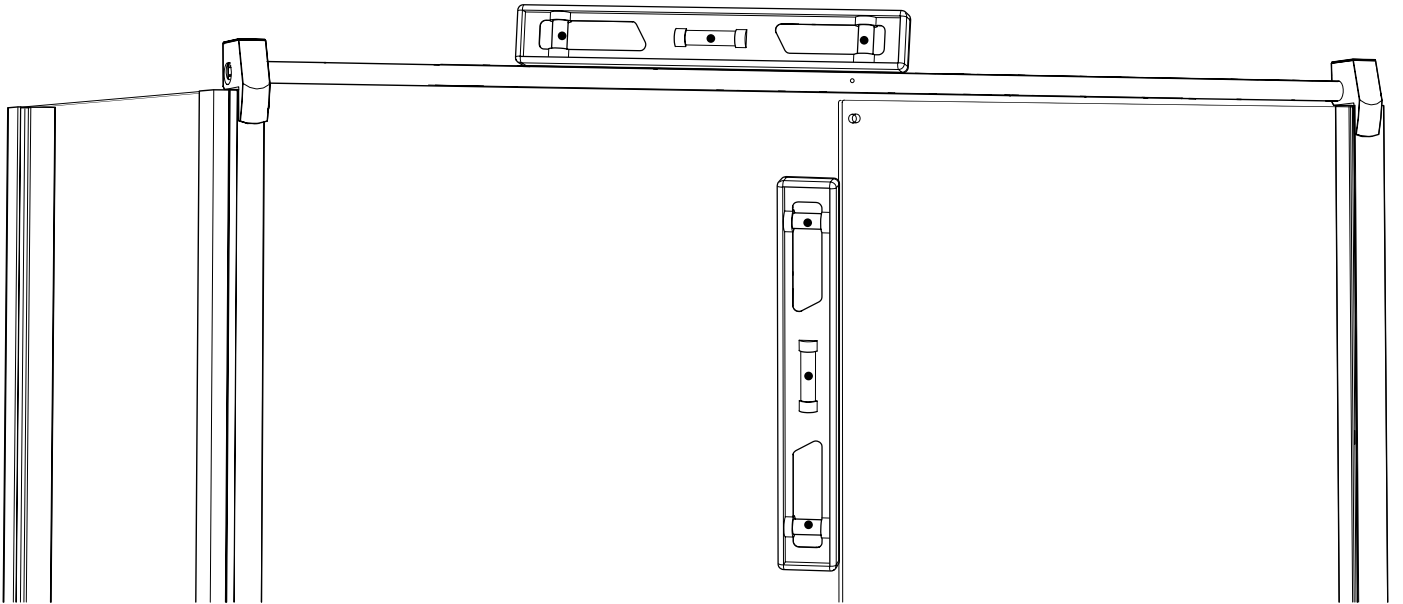

MARK THE U-CHANNEL PLACEMENT / MARQUER L'EMPLACEMENT DU PROFILÉ EN «U»

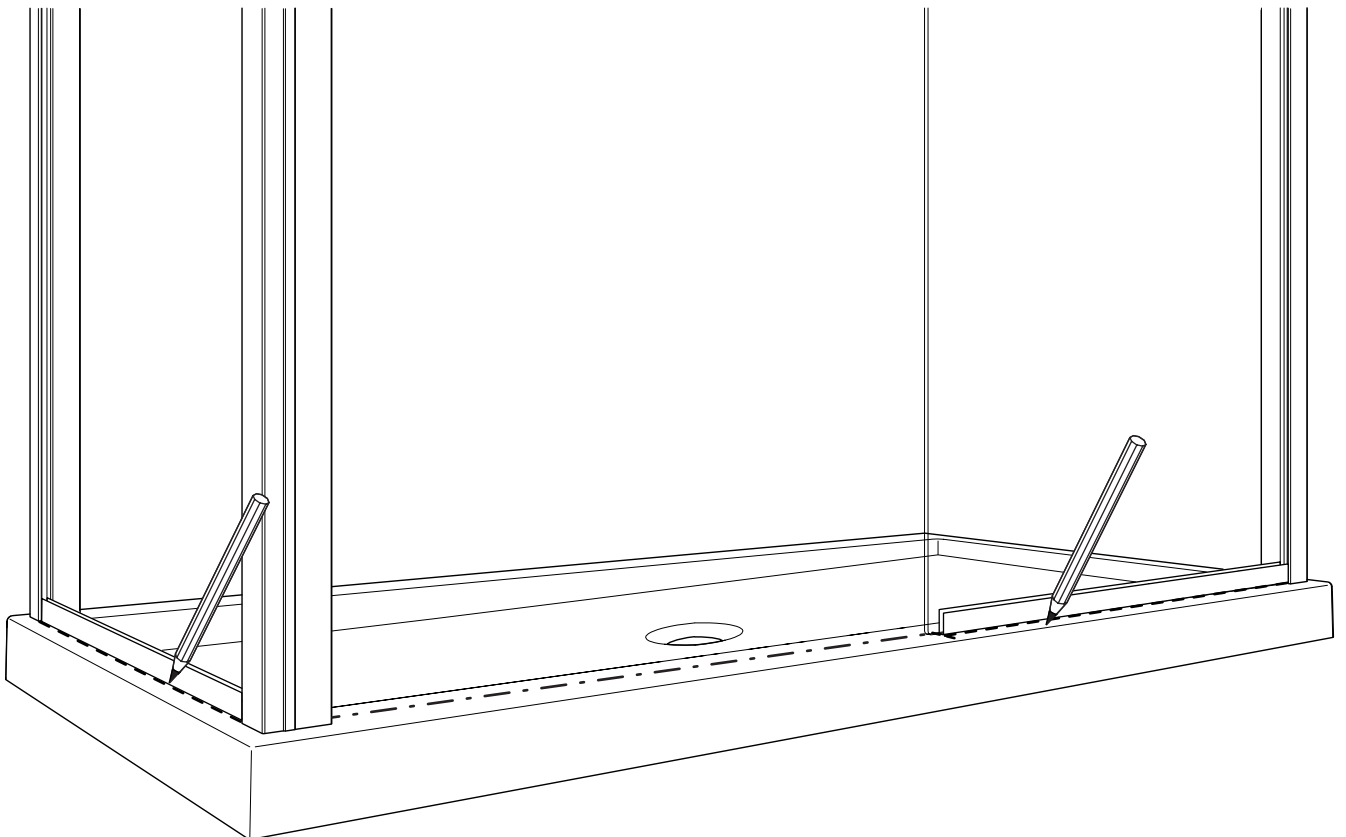

REMOVE THE RAIL BAR AND BOTH PANELS / ENLEVER LA BARRE DE ROULEMENT ET LES PANNEAUX

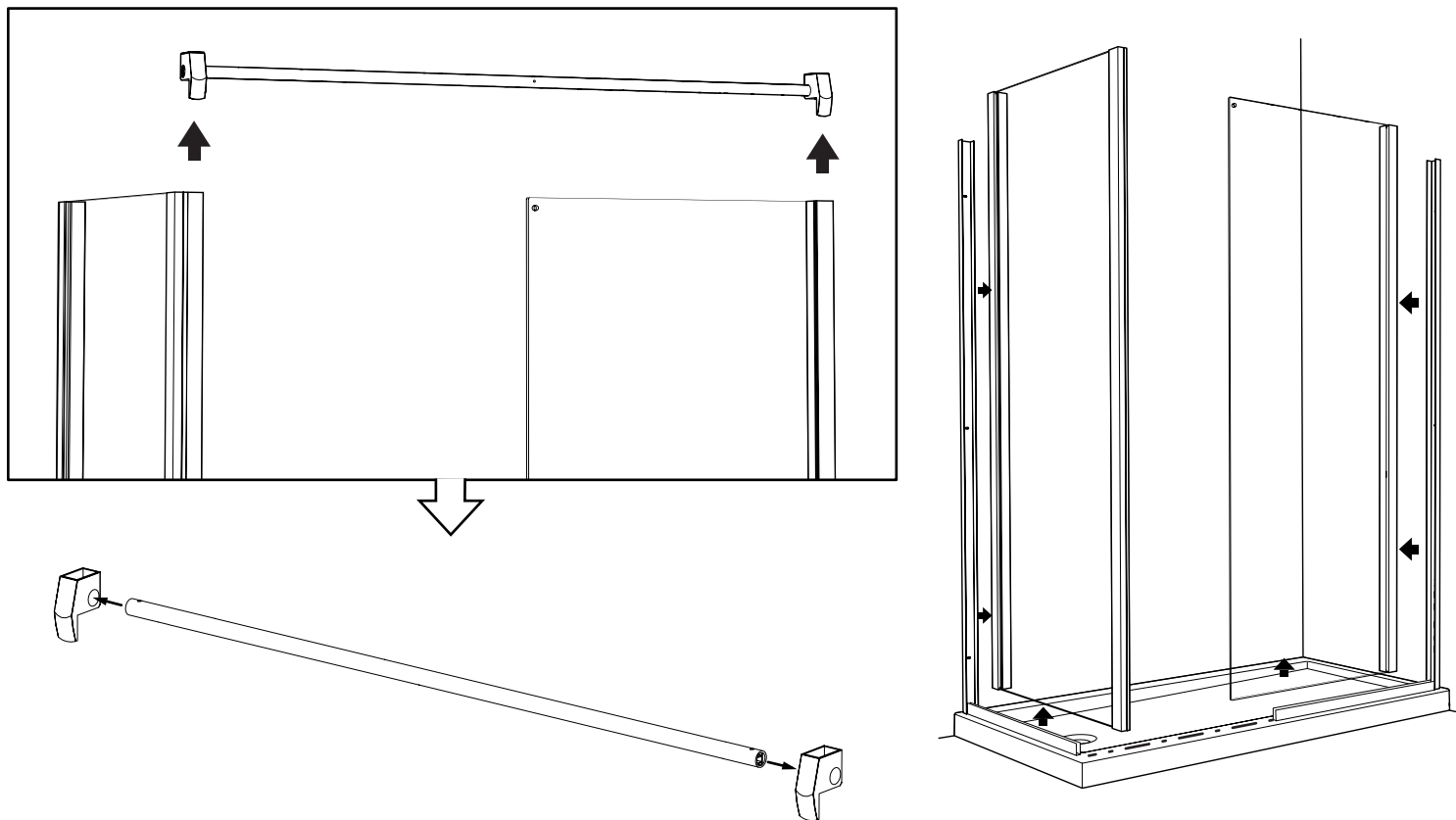

INSTALL THE U-CHANNELS / INSTALLER LES PROFILÉS EN «U»

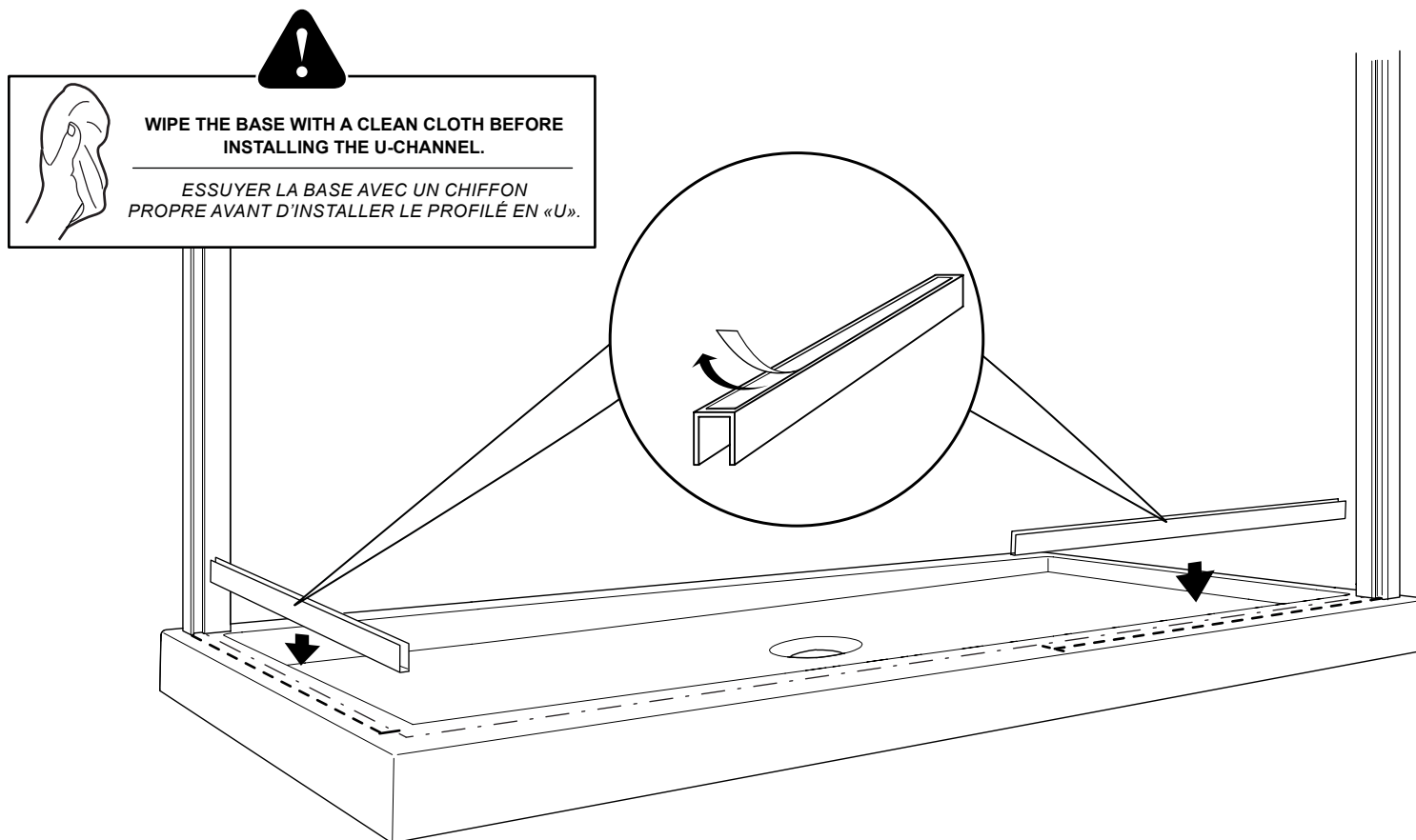

INSTALL THE RETURN PANEL / INSTALL THE RETURN PANEL

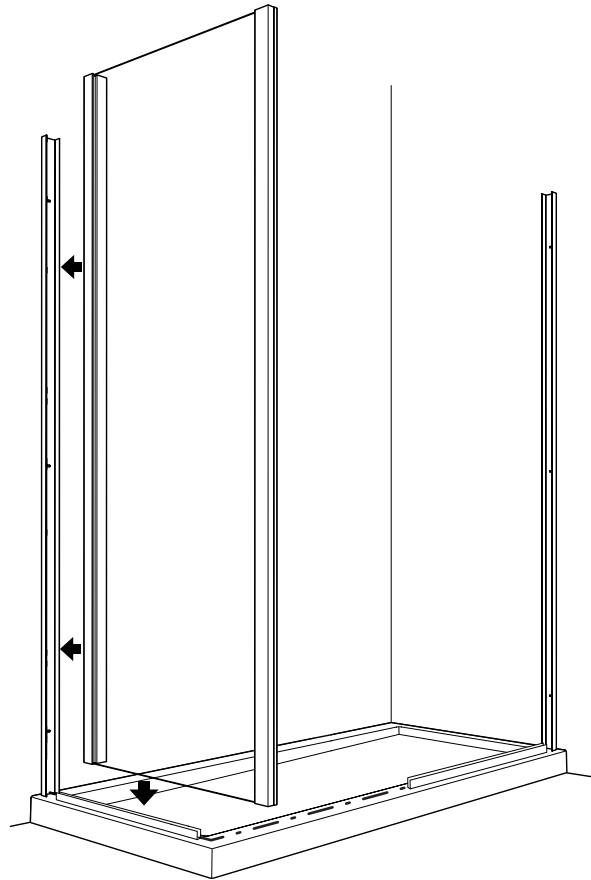
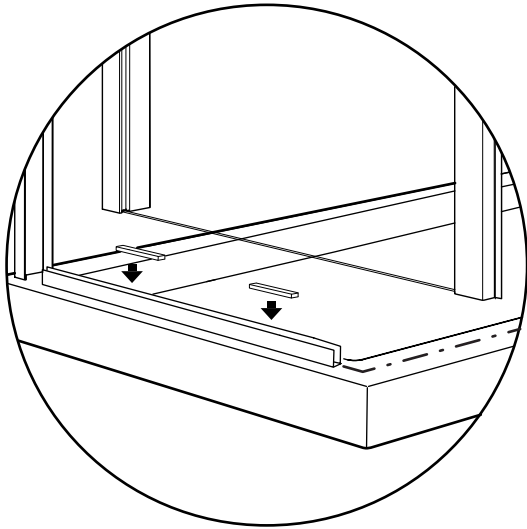

PLACE THE ANCHORING BLOCK / PLACER LE BLOC D'ANCRAGE

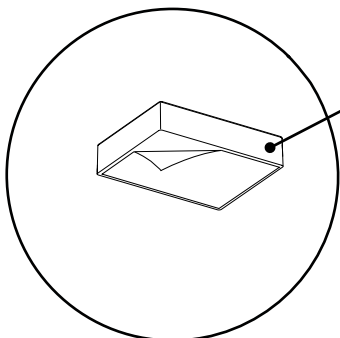

19

**WIPE THE BASE WITH A CLEAN CLOTH BEFORE
INSTALLING THE ANCHORING BLOCK.**

*NETTOYER LA BASE AVEC UN CHIFFON PROPRE
AVANT D'INSTALLER LE BLOC D'ANCRAGE.*

**INTERIOR
SHOWER SIDE
INTÉRIEUR
DE LA DOUCHE**

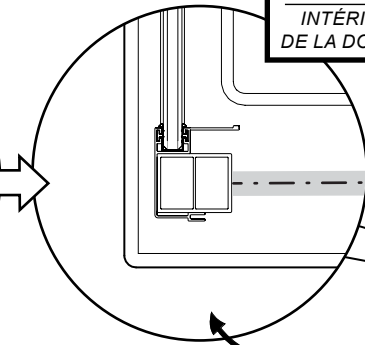
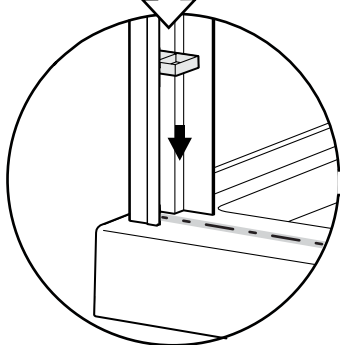

**PLAN VIEW
VUE EN PLAN**

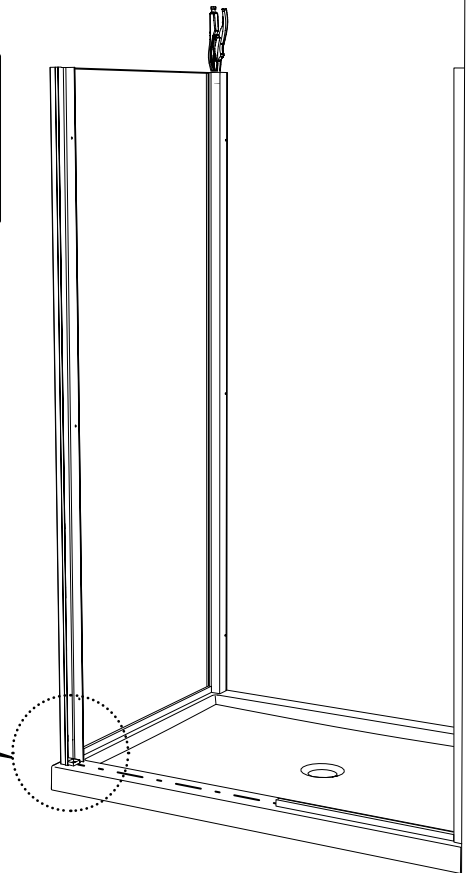

INSTALL THE DOOR PANEL EXPANDER AND LEVEL / INSTALL THE RETURN PANEL

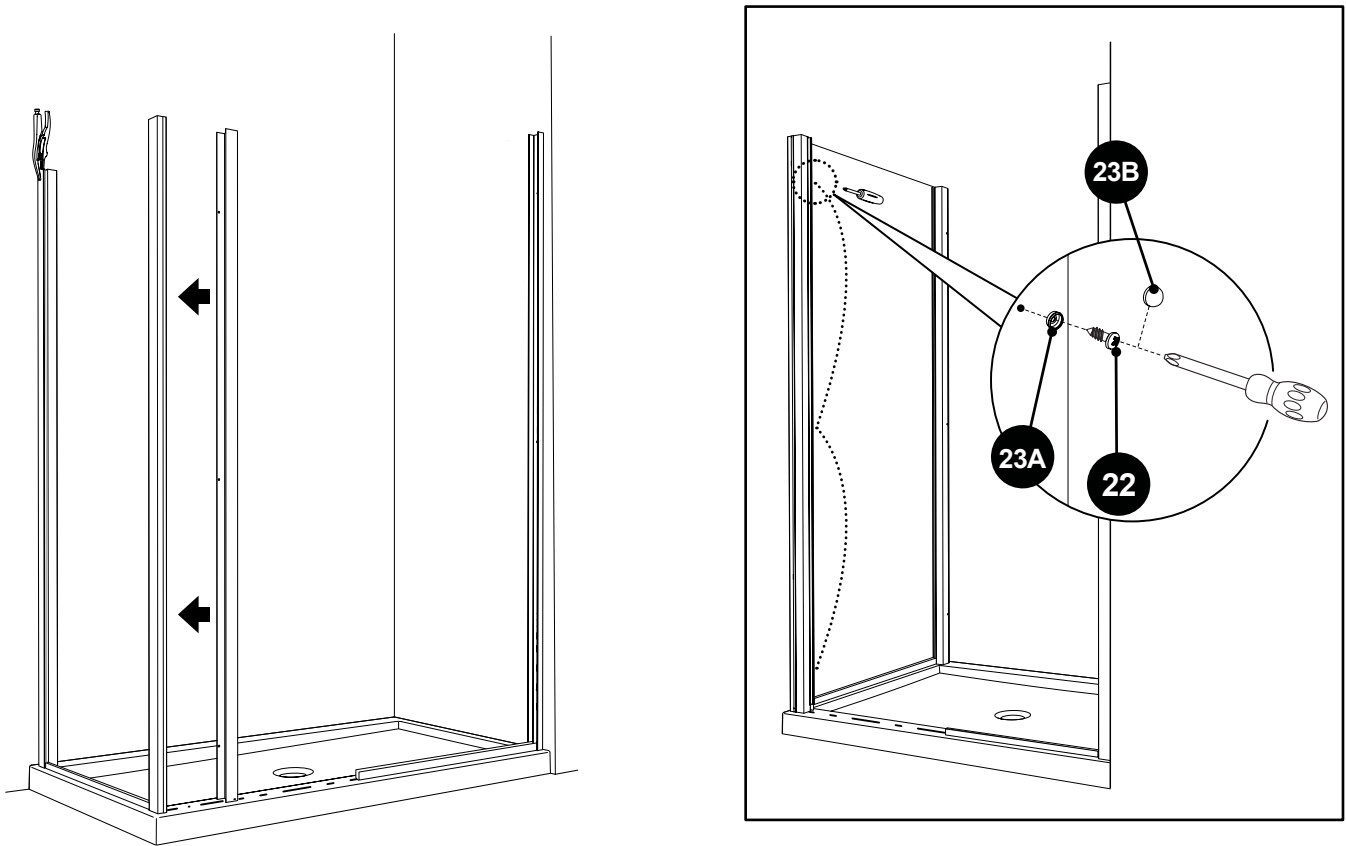

DETERMINE THE FIXED PANEL SIDE OF THE RAIL BAR
DÉTERMINER LE CÔTÉ DU PANNEAU FIXE SUR LA BARRE DE ROULEMENT

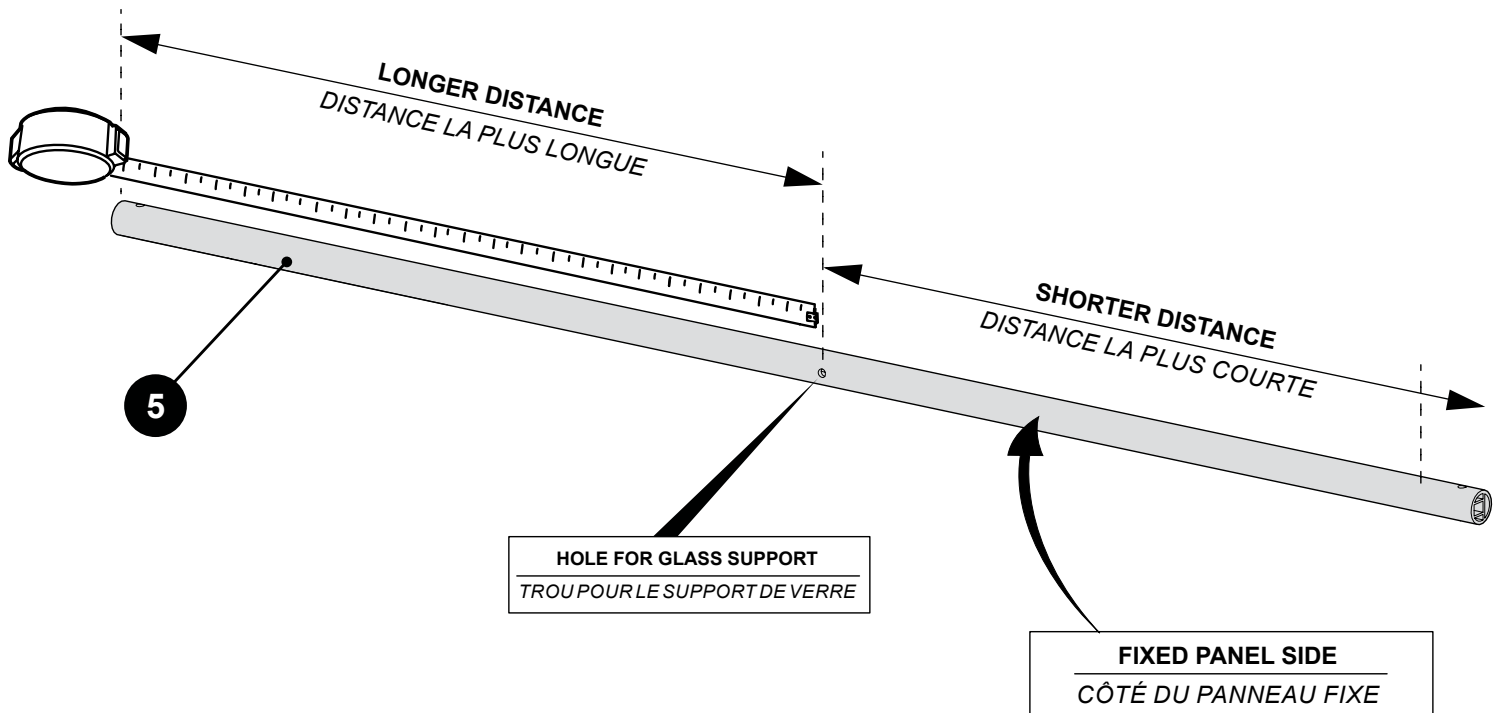

ASSEMBLE THE RAIL BAR / ASSEMBLER LA BARRE

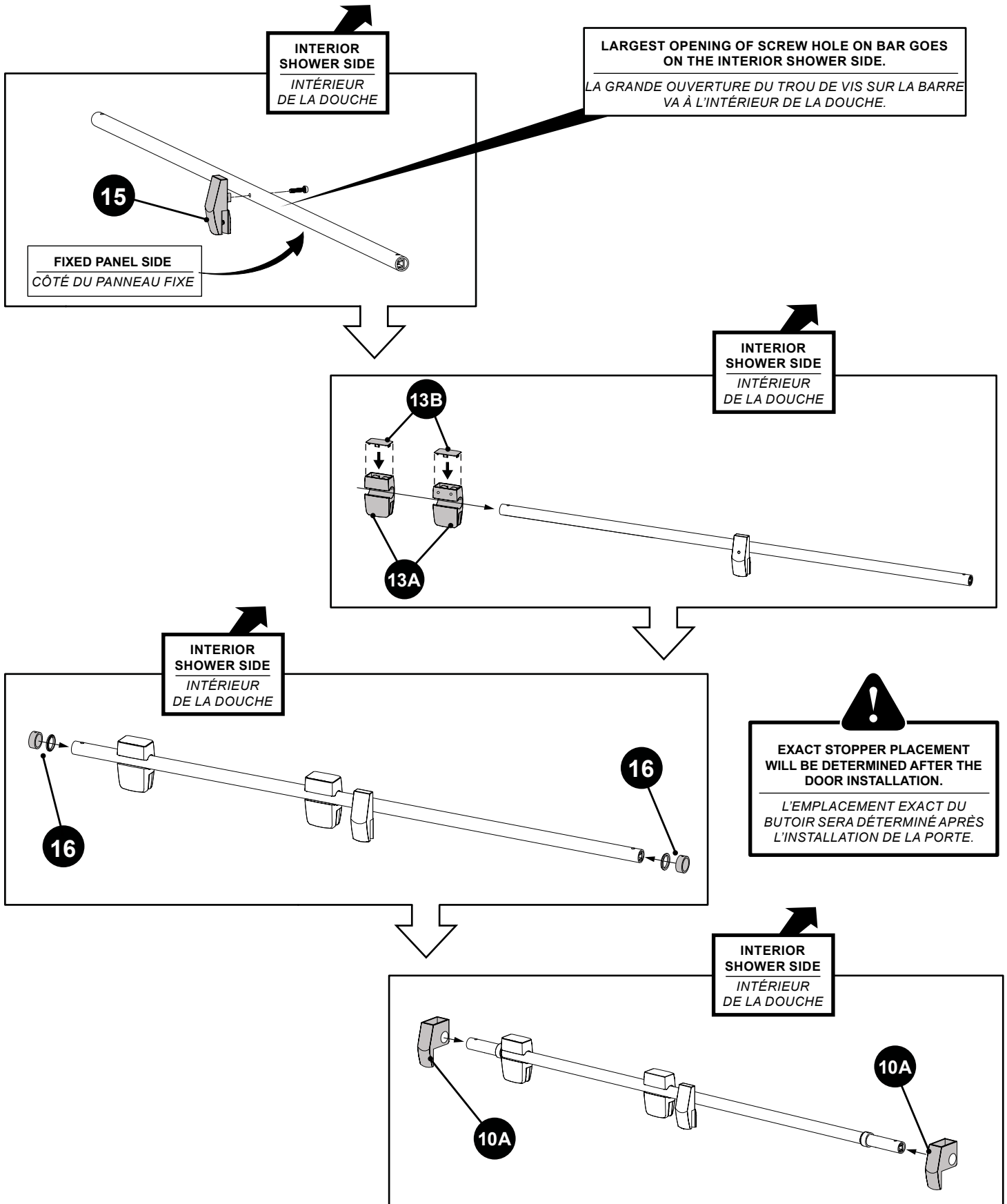

INSTALL THE FIXED PANEL / INSTALLER LE PANNEAU FIXE

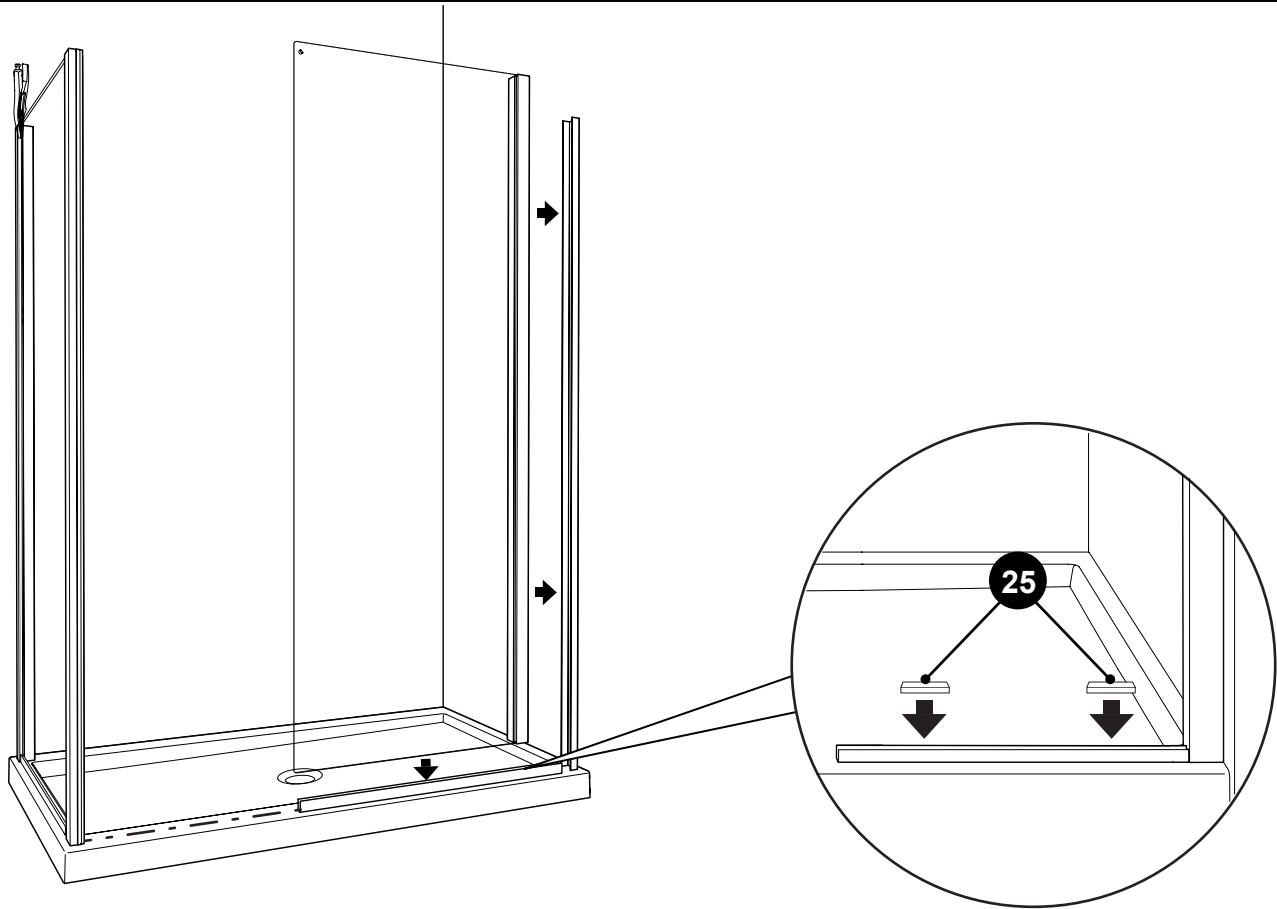

INSTALL THE RAIL BAR / INSTALLER LA BARRE DE ROULEMENT

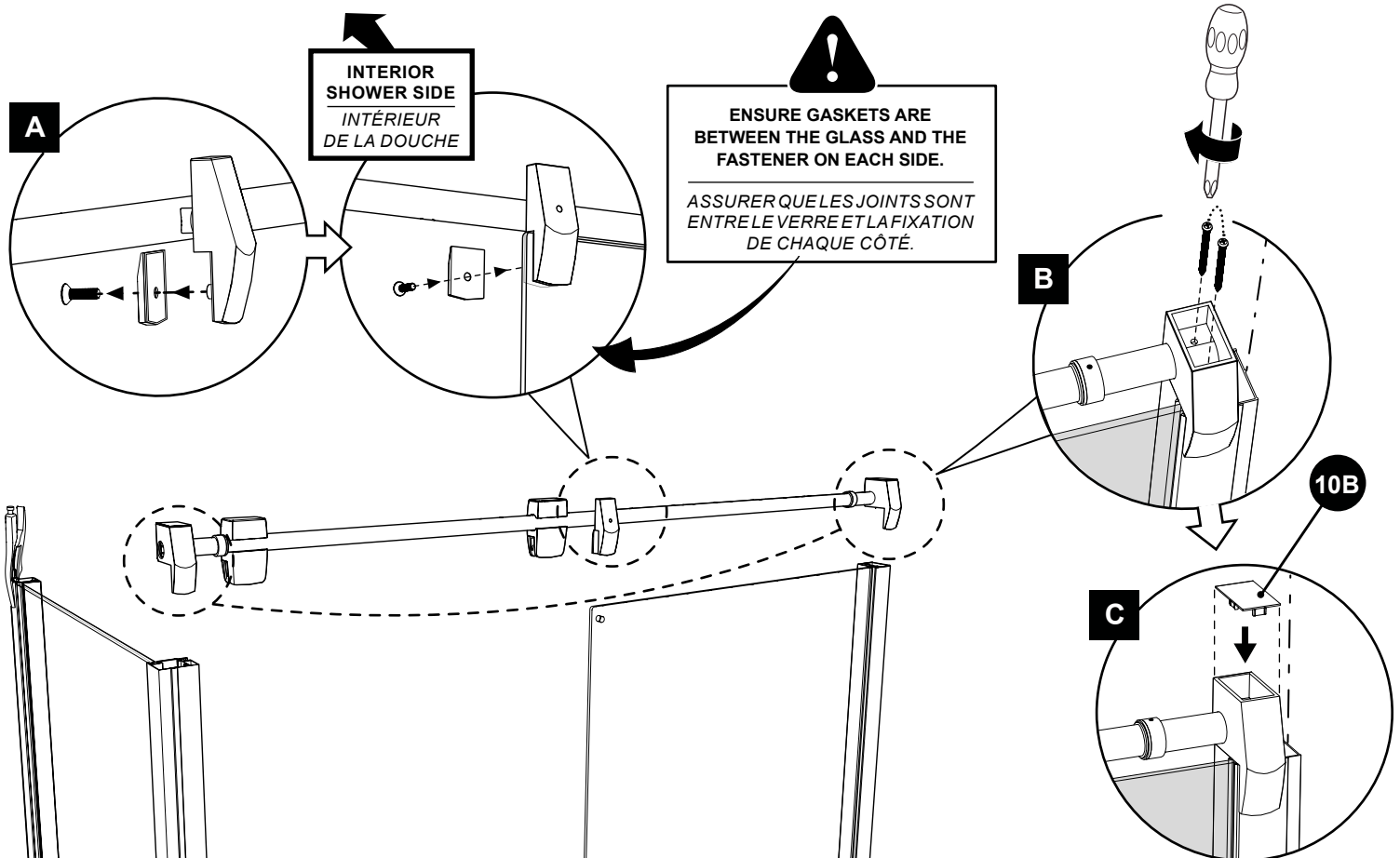

SECURE THE EXPANDERS / SÉCURISER LES EXTENSEURS

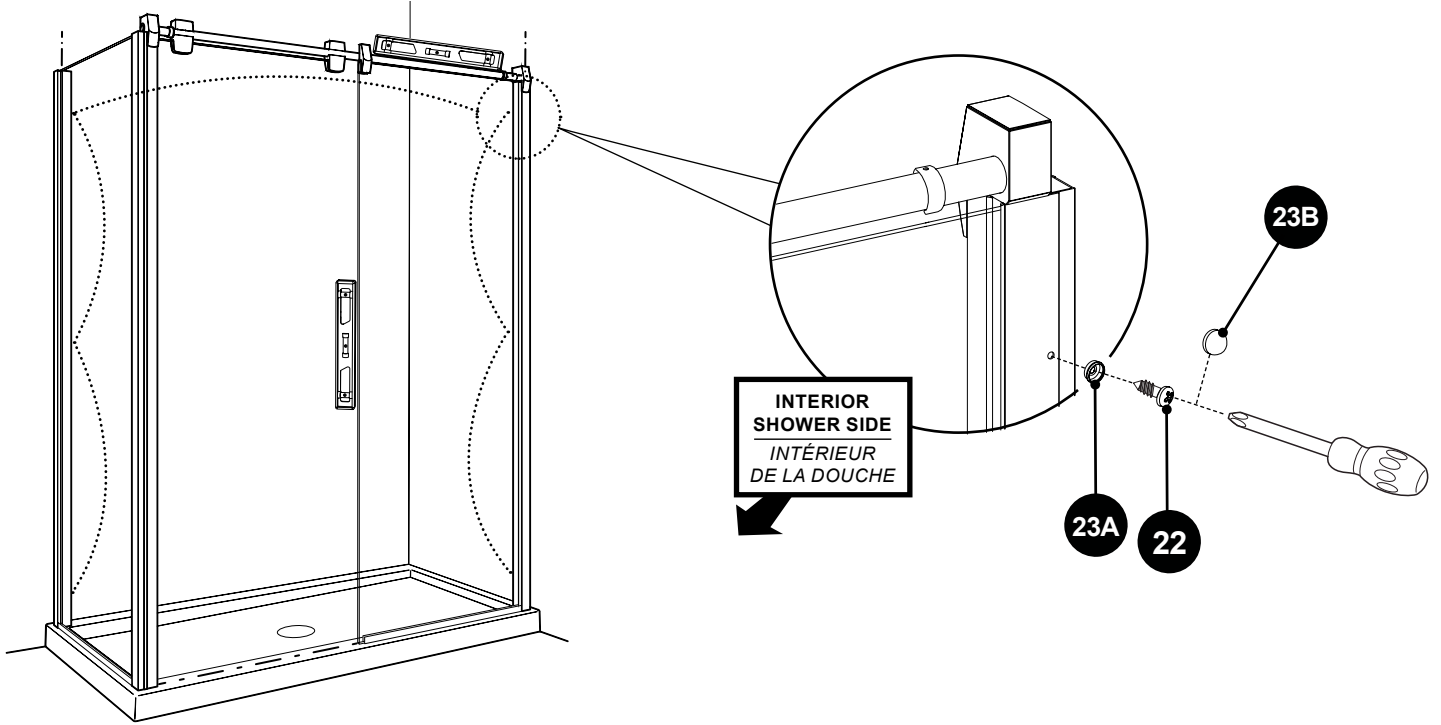

INSTALL THE DOOR GUIDE / INSTALLER LE GUIDE DE PORTE

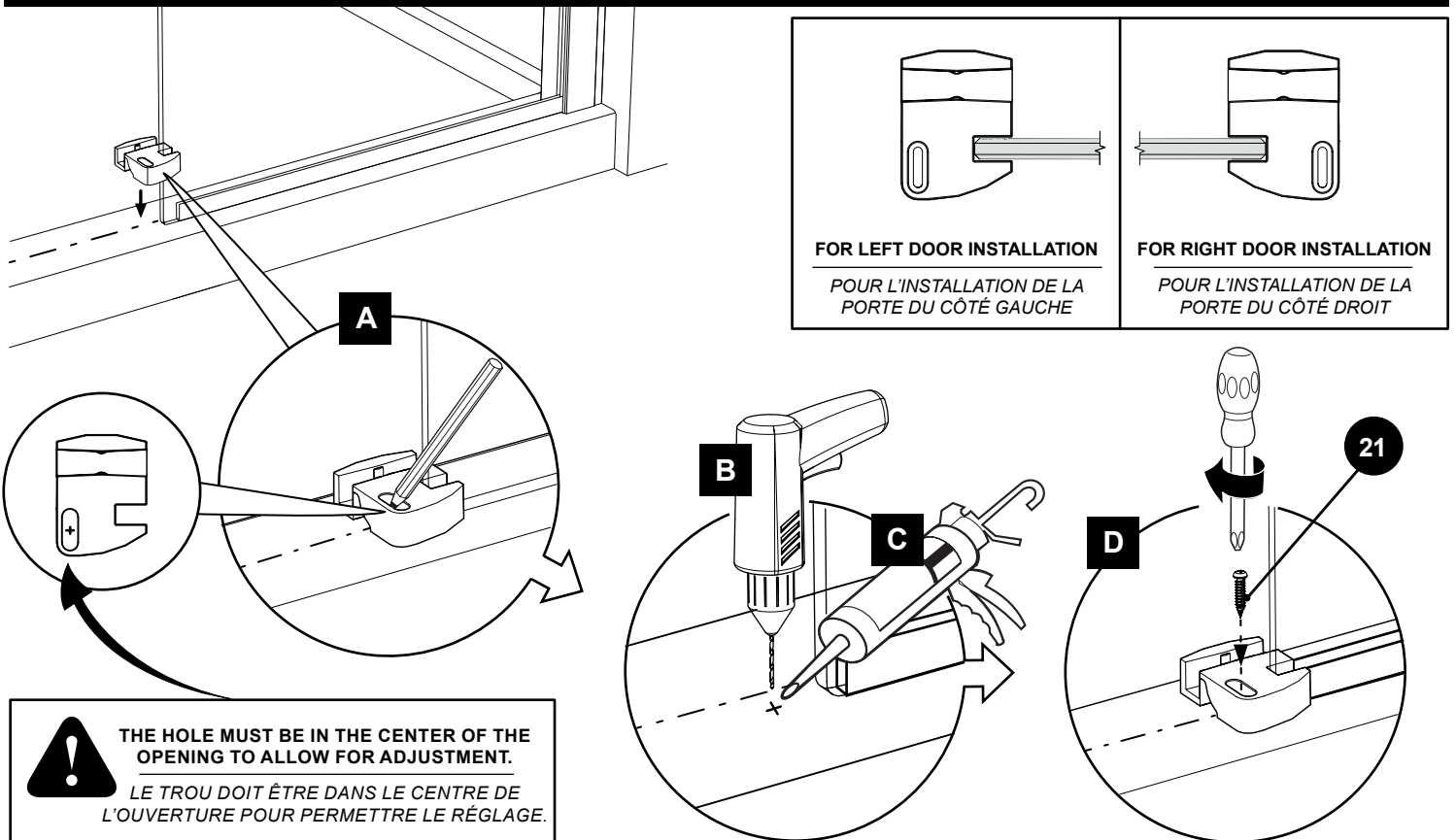

INSTALL THE DOOR HANDLE / INSTALLER LA POIGNÉE DE PORTE

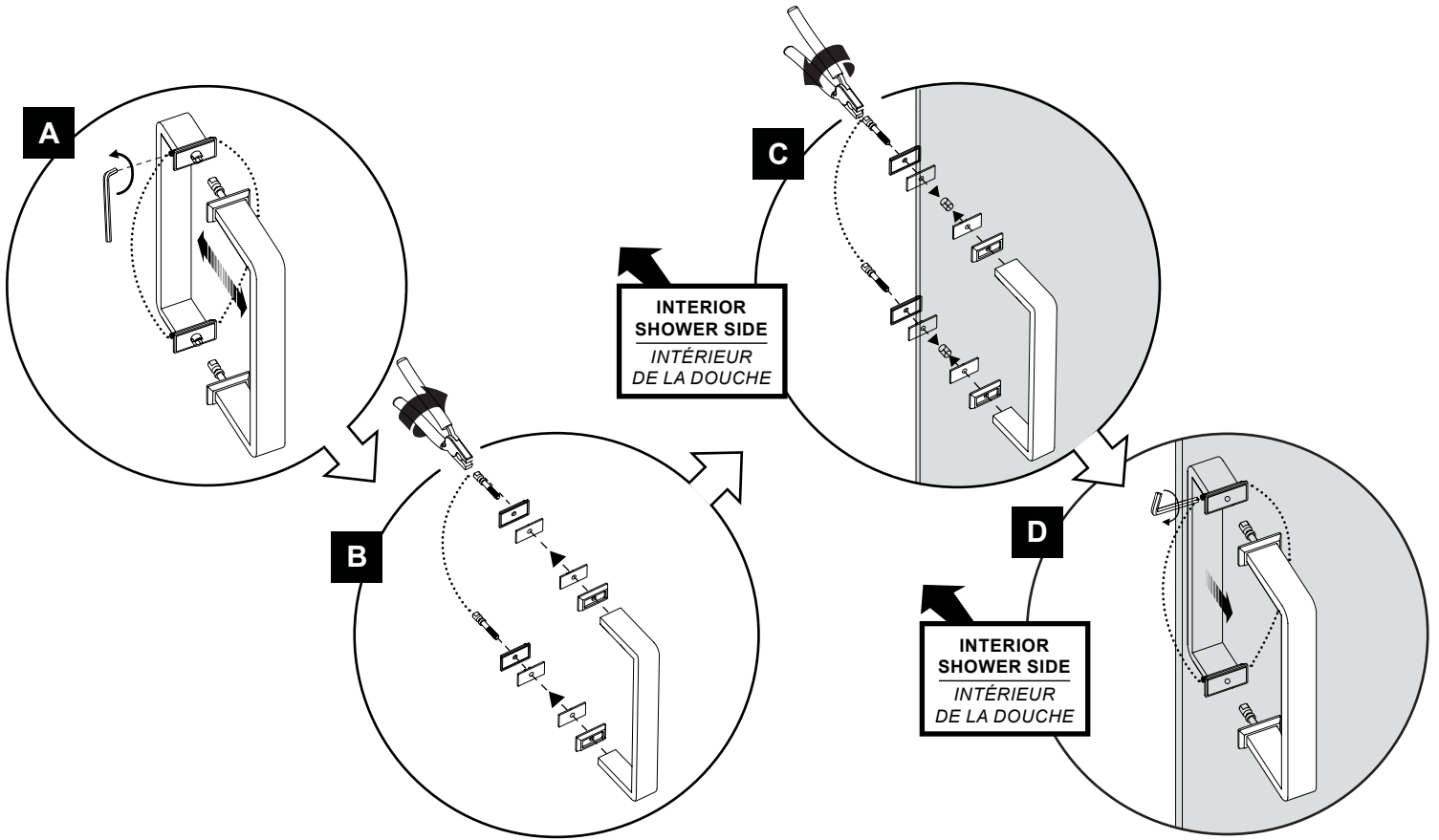

INSTALL THE DOOR PANEL / INSTALLER LE PANNEAU DE PORTE

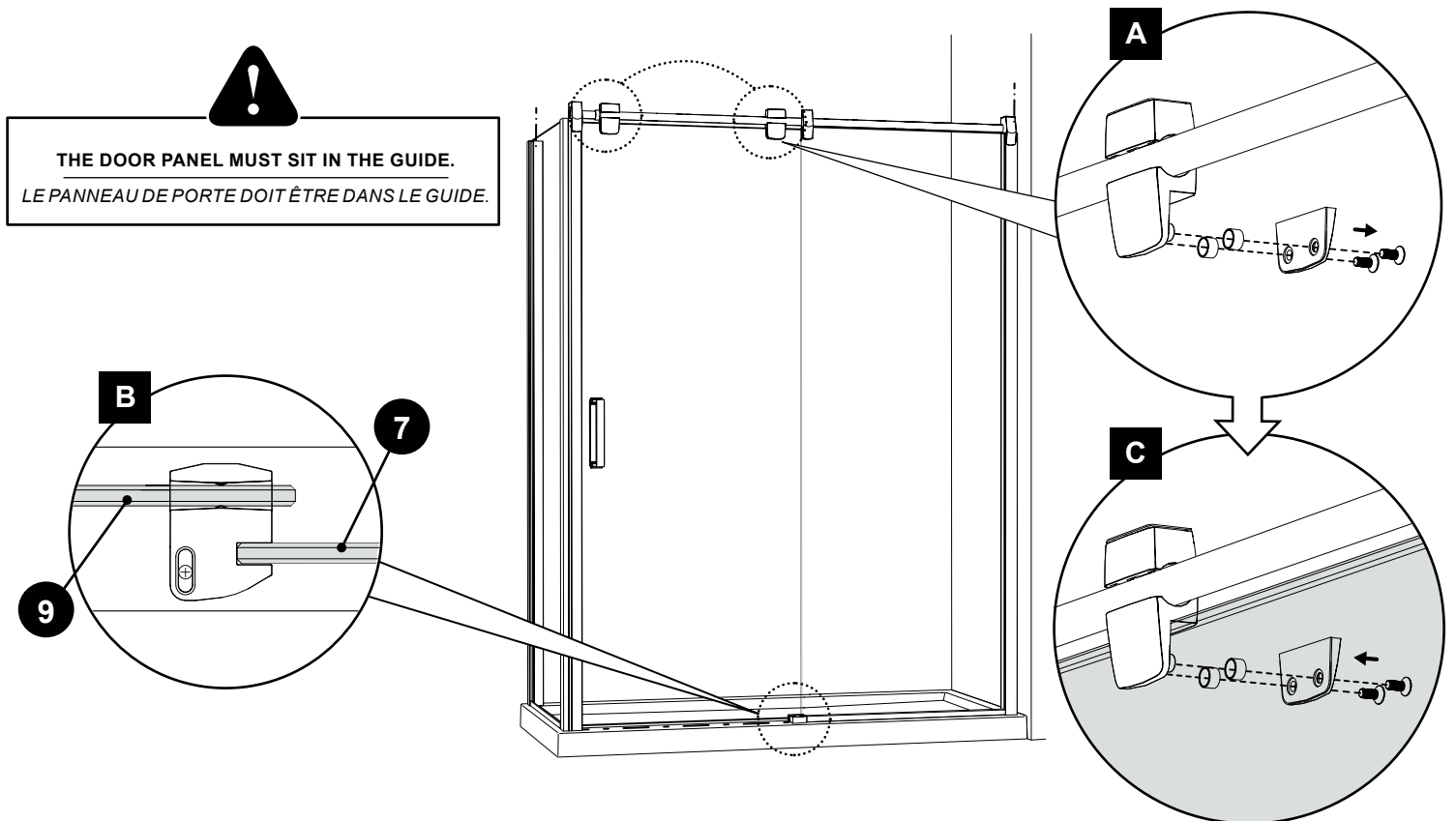

POSITION THE STOPPERS / POSITIONNER LES BUTOIRS

POSITION THE STOPPER SO THAT IT LIES FLUSH WITH THE ROLLER SUPPORT WHEN THE DOOR IS IN THE CLOSED POSITION.

POSITIONNER LE BUTOIR DE SORTE QU'IL REPOSE AU RAS AVEC LE SUPPORT DE ROULEAU LORSQUE LA PORTE EST DANS LA POSITION FERMÉE.

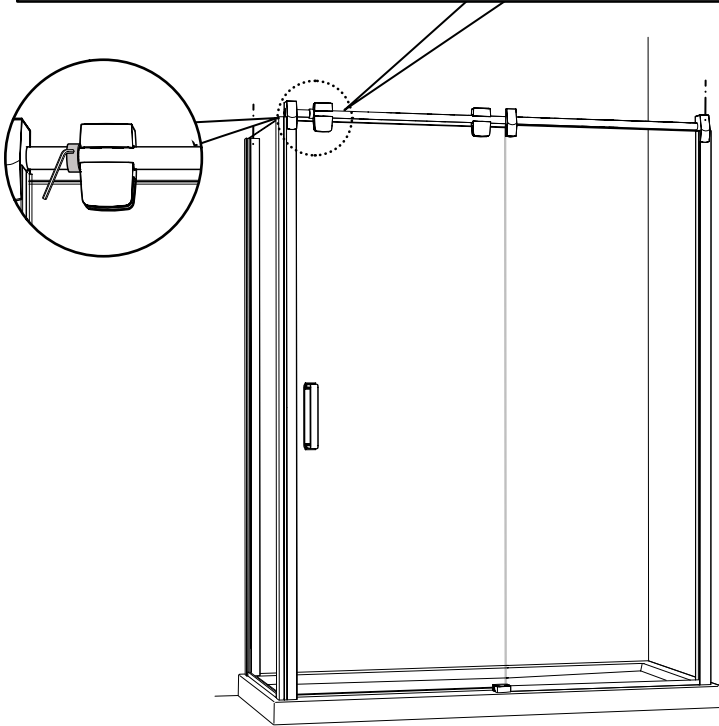

POSITION THE STOPPER SO THAT IT PREVENTS THE HANDLE FROM HITTING THE FIXED PANEL WHEN THE DOOR IS OPEN. ⚠

POSITIONNER LE BUTOIR DE SORTE QU'IL EMPÊCHE LA POIGNÉE DE FRAPPER LE PANNEAU FIXE QUAND LA PORTE EST OUVERTE. ⚠

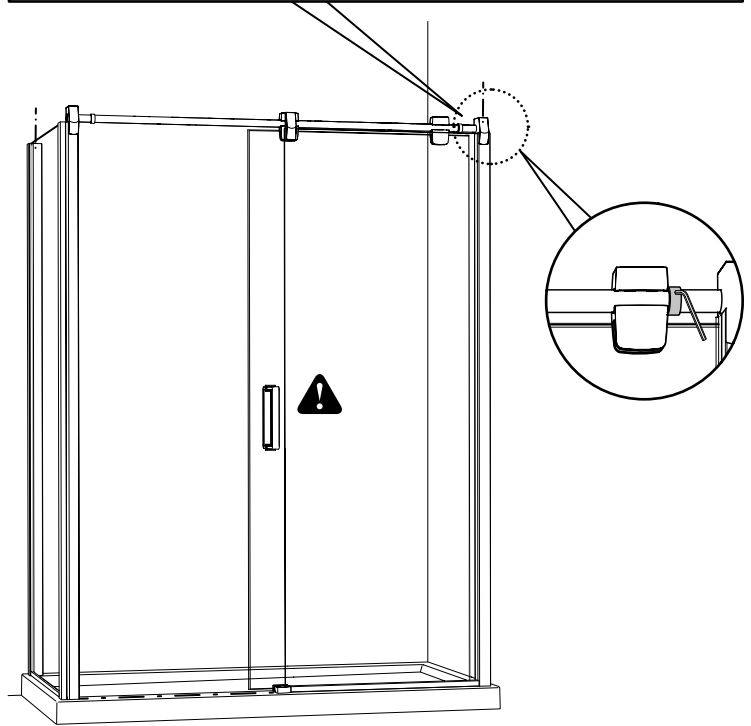

INSTALL THE THRESHOLD / INSTALLER LE SEUIL

⚠
THRESHOLD SHOULD FIT BETWEEN THE DOOR GUIDE AND DOOR RECEIVER. TRIM IF NECESSARY.

LE SEUIL DOIT ÊTRE ENTRE LE GUIDE DE PORTE ET LE RÉCEPTEUR DE PORTE. COUPER SI NÉCESSAIRE.

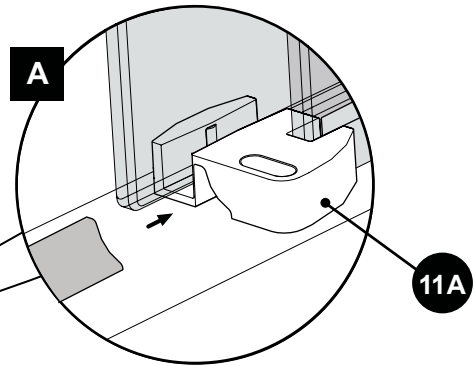
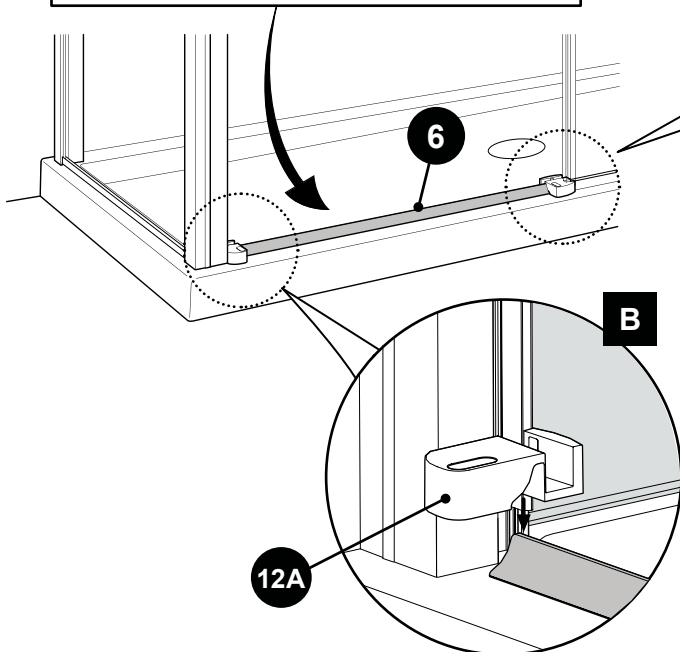

PLACE THRESHOLD BACK ON BASE AFTER APPLYING SILICONE.

REMETTRE SUR LA BASE APRÈS APPLICATION DE SILICONE.

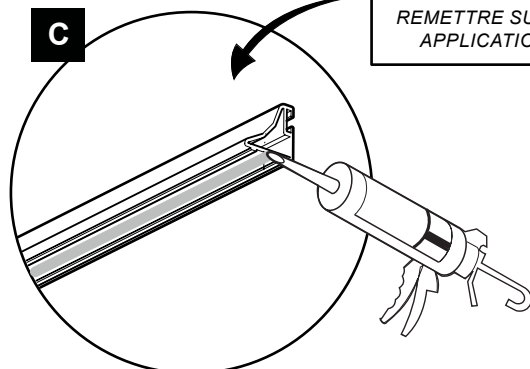

INSTALL THE DOOR RECEIVER / INSTALLER LE RÉCEPTEUR DE PORTE



LIFT THE GASKET AND CLOSE THE DOOR BEFORE MARKING THE DOOR RECEIVER HOLE POSITION.

SOULEVER LE JOINT ET FERMER LA PORTE AVANT DE MARQUER LE TROU POUR LE RÉCEPTEUR DE PORTE.

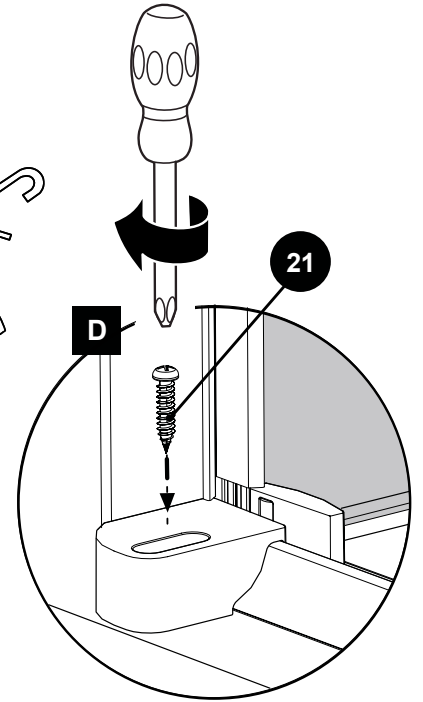
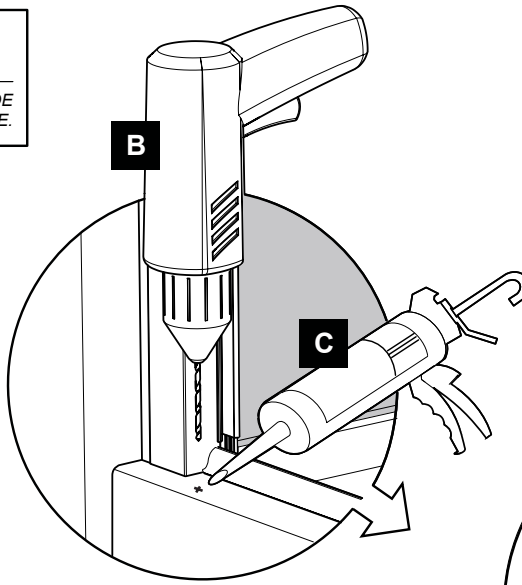
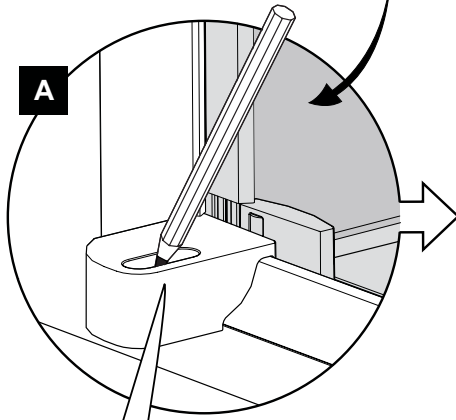

THE HOLE MUST BE IN THE CENTER OF THE OPENING TO ALLOW FOR ADJUSTMENT.

LE TROU DOIT ÊTRE DANS LE CENTRE DE L'OUVERTURE POUR PERMETTRE LE RÉGLAGE.

ADJUST IF NECESSARY & ADD COVERS / AJUSTER SI NÉCESSAIRE & AJOUTER LES CAPUCHONS

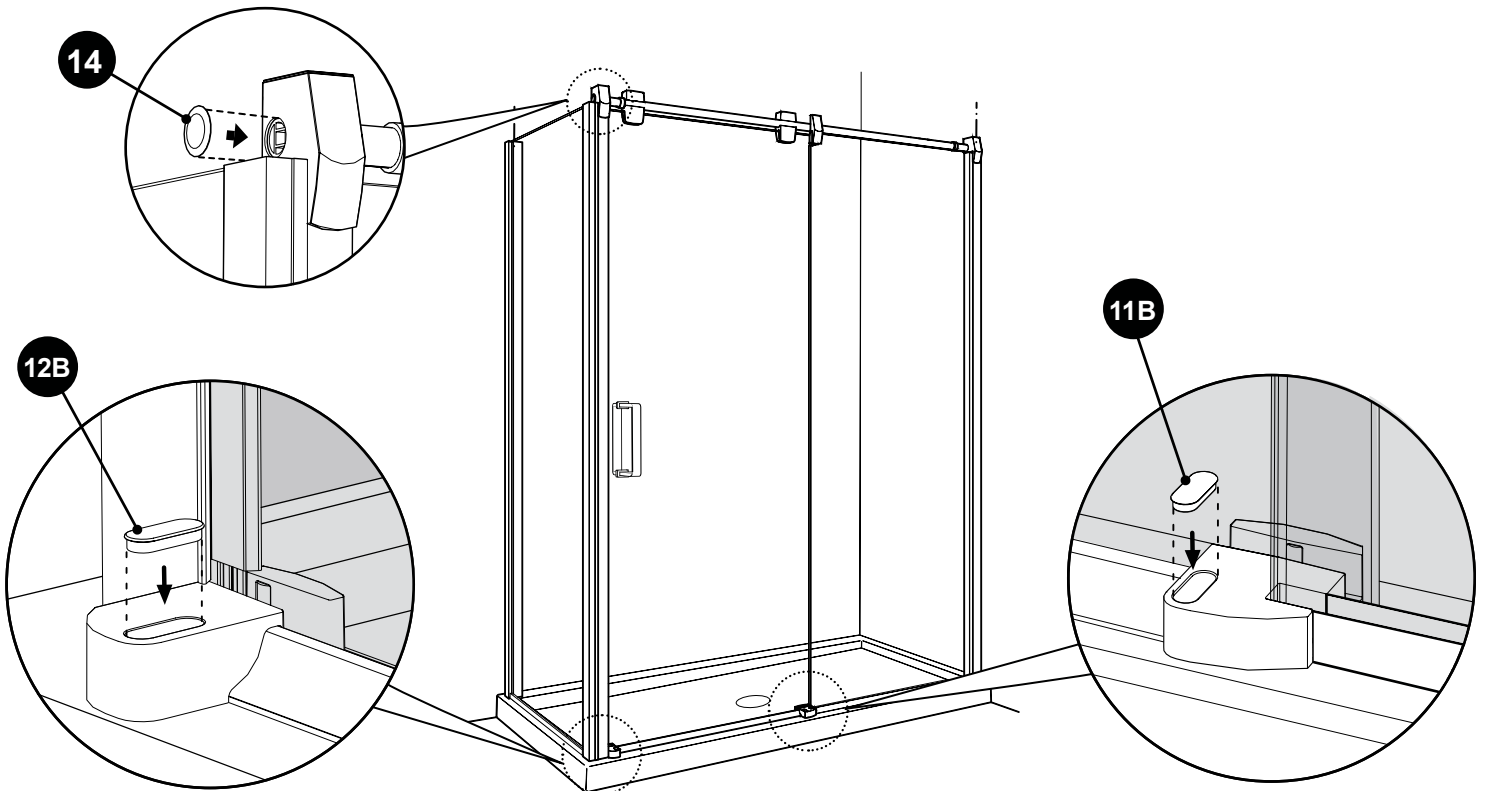

INSTALL MID GASKETS / INSTALLER LES JOINTS LATÉRAUX

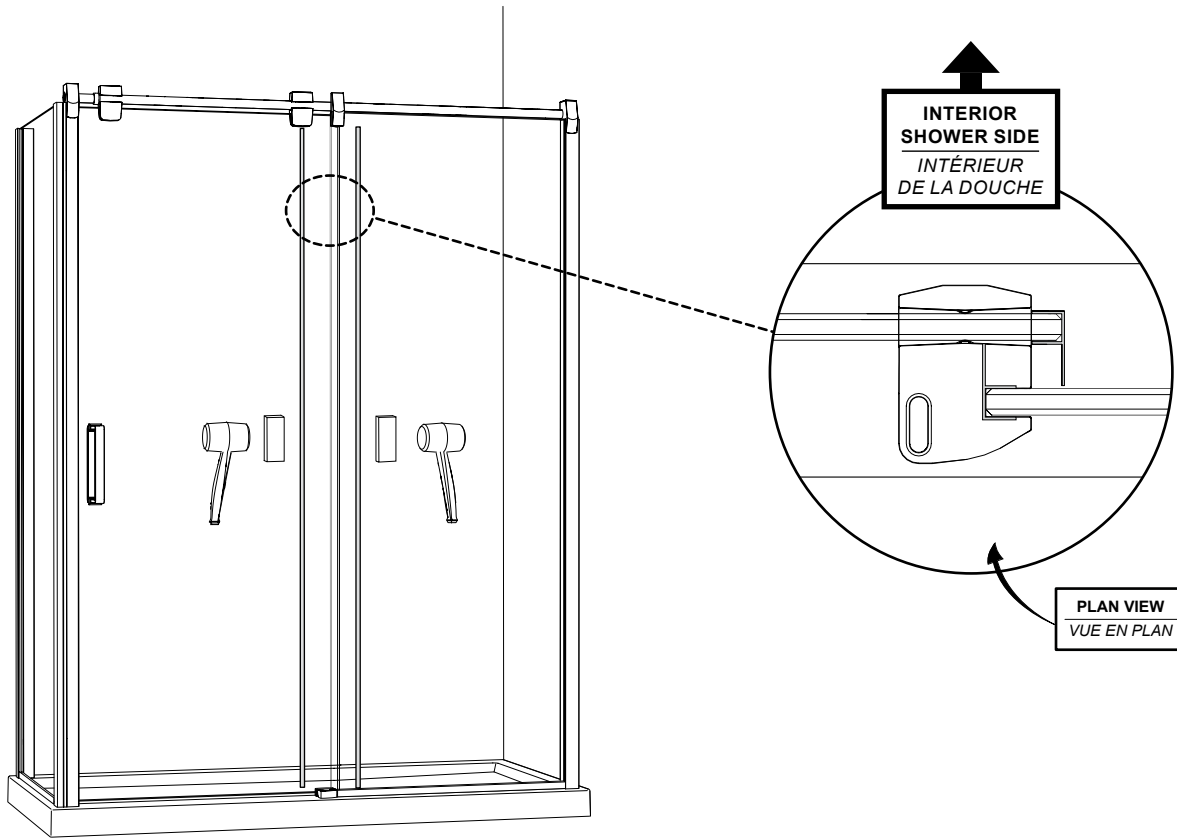

SEALING / CALFEUTRAGE

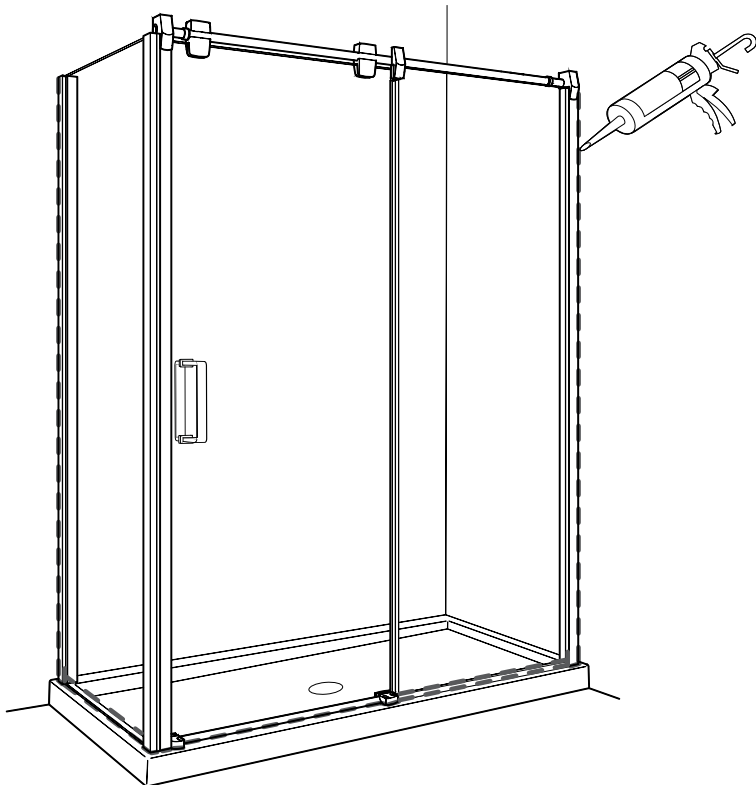

24 HOURS
HEURES