

INSTALLATION MANUAL - *GUIDE D'INSTALLATION*

MC03

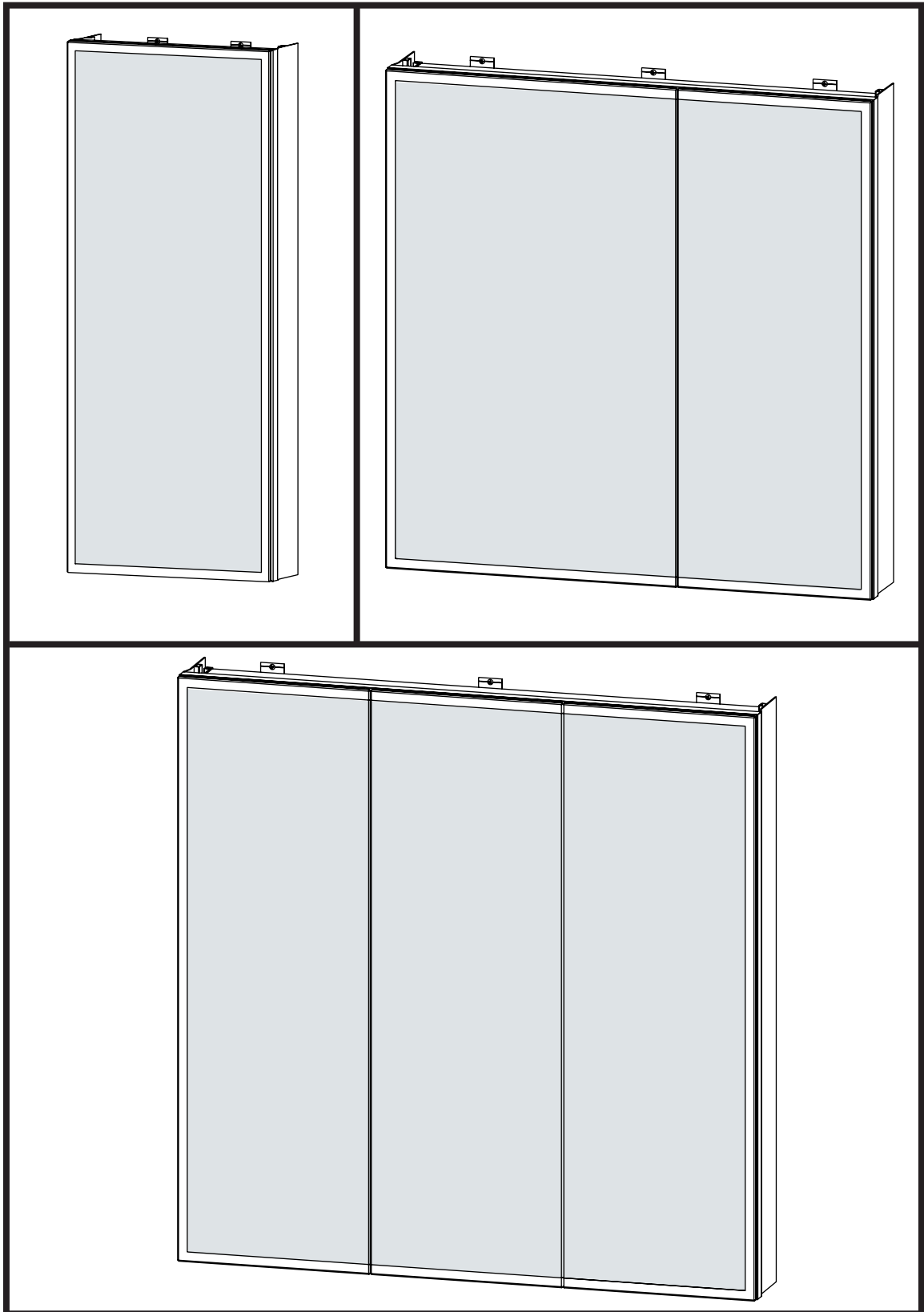

Please keep this manual and product code number for future reference
and for ordering replacement parts if necessary.

*Veillez conserver ce manuel et le code de produit pour des références futures,
et au besoin, la commande de pièces de rechange.*

THANK YOU / MERCI

We can assure you that FLEURCO has used the best materials and has applied the strictest quality control measures to ensure that each and every unit meets the highest quality standards. This booklet contains general information about the unit as well as step-by-step installation instructions.

Nous pouvons vous assurer que FLEURCO a utilisé les meilleurs matériaux et a appliqué les mesures les plus strictes de contrôle de qualité afin de garantir que chaque unité répond aux normes de haute qualité. Cette brochure contient des informations générales sur cette unité ainsi que des instructions étape-par-étape pour l'installer.

BEFORE BEGINNING / AVANT DE COMMENCER

Carefully read the instructions before beginning the installation.

- It is recommended that you wear safety glasses at all times during the installation.
- Observe all local plumbing and building codes.
- It is strongly recommended that this installation be performed by a professional plumber or contractor.

Lire attentivement les instructions avant de débiter l'installation.

- *Il est recommandé de porter des lunettes de sécurité en tout temps lors de l'installation.*
- *Respecter tous les codes de plomberie et de bâtiment locaux.*
- *L'installation par un plombier accrédité ou un contracteur est fortement suggérée*

TOOLS REQUIRED / OUTILS REQUIS

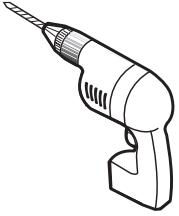

DRILL
PERCEUSE



3/32" DRILL BITS
MÈCHE 3/32"

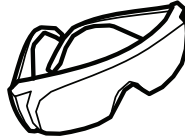

SAFETY GLASSES
LUNETTES DE SÉCURITÉ



SCREWDRIVER
TOURNEVIS

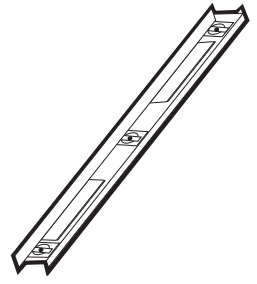

LEVEL
NIVEAU

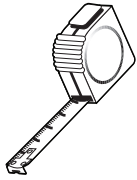

TAPE MEASURE
RUBAN À MESURER



PENCIL
CRAYON



STUD DETECTOR
DÉTECTEUR DE MONTANTS

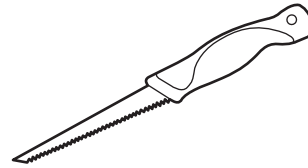

CEMENT BOARD SAW
SCIE À GYPSE

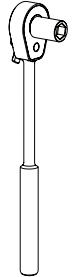

7MM 9/32" WRENCH
7MM 9/32"

POSSIBLE CONFIGURATIONS / CONFIGURATIONS POSSIBLES

*

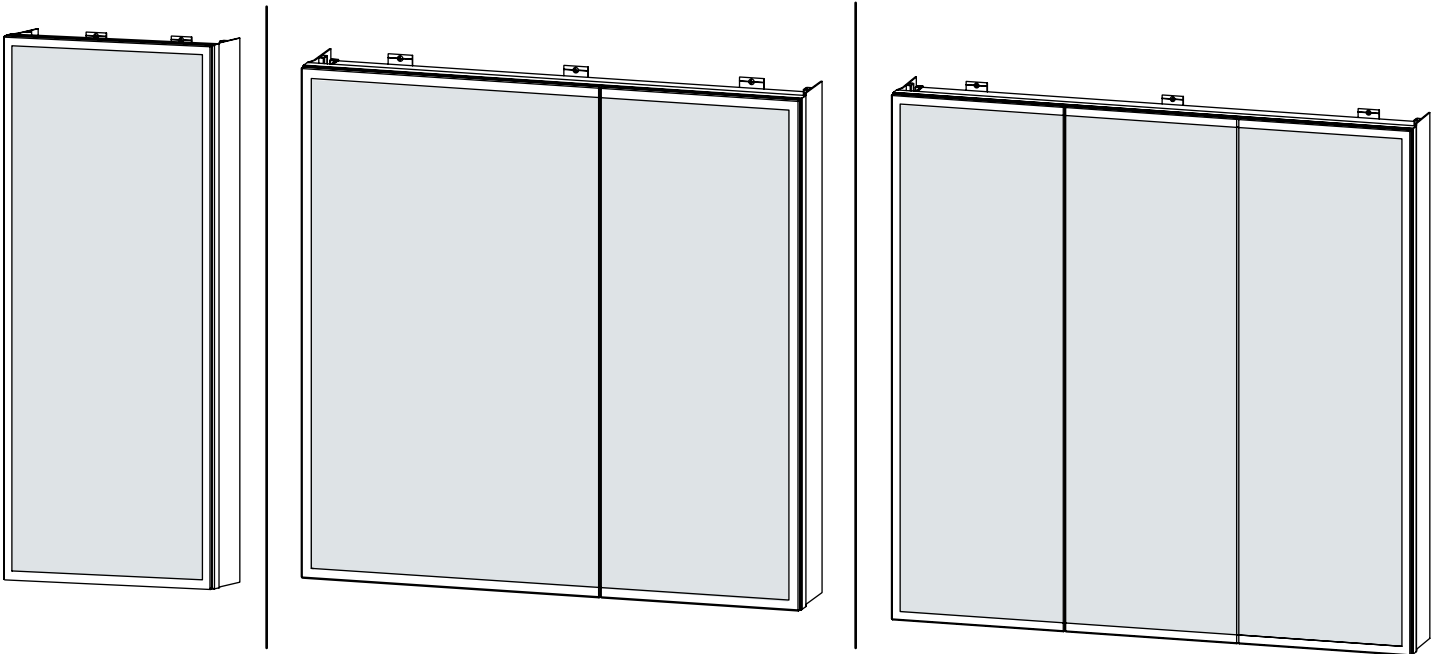

* This configuration is illustrated in this manual.

* Cette configuration est illustrée dans ce manuel.

PARTS LISTING / LISTE DES PIÈCES

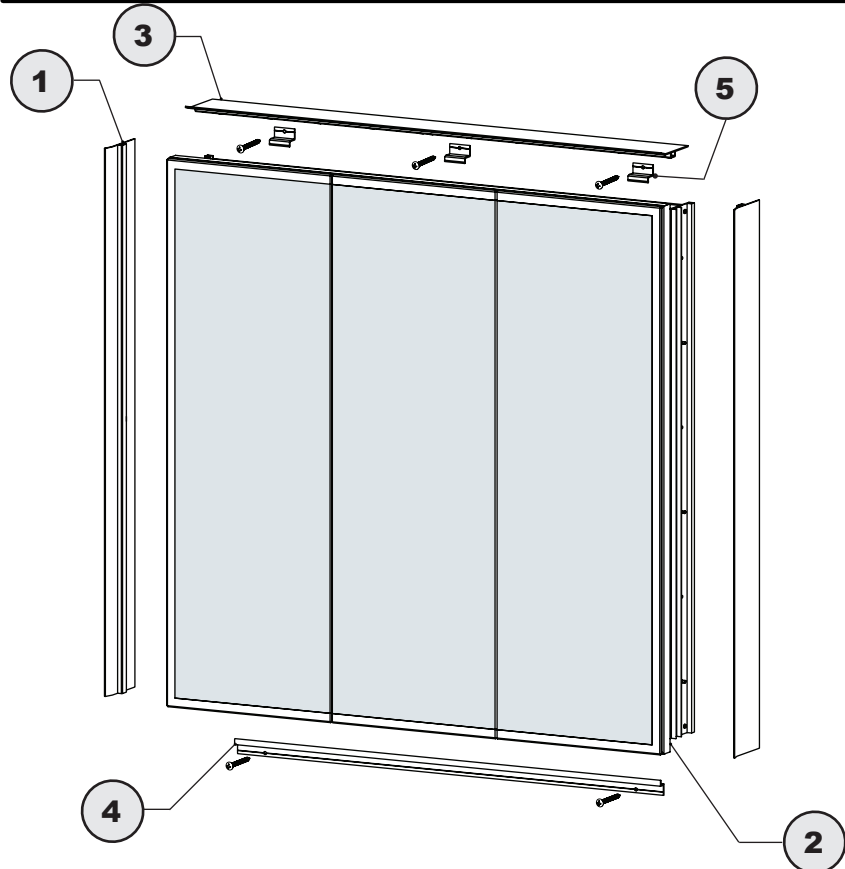
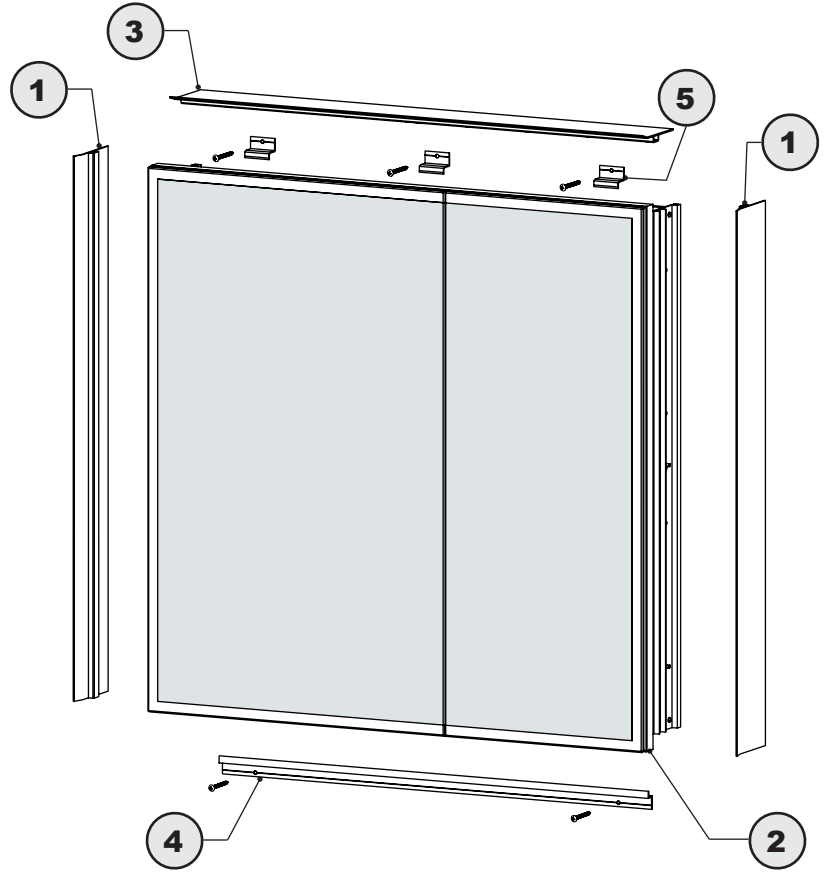
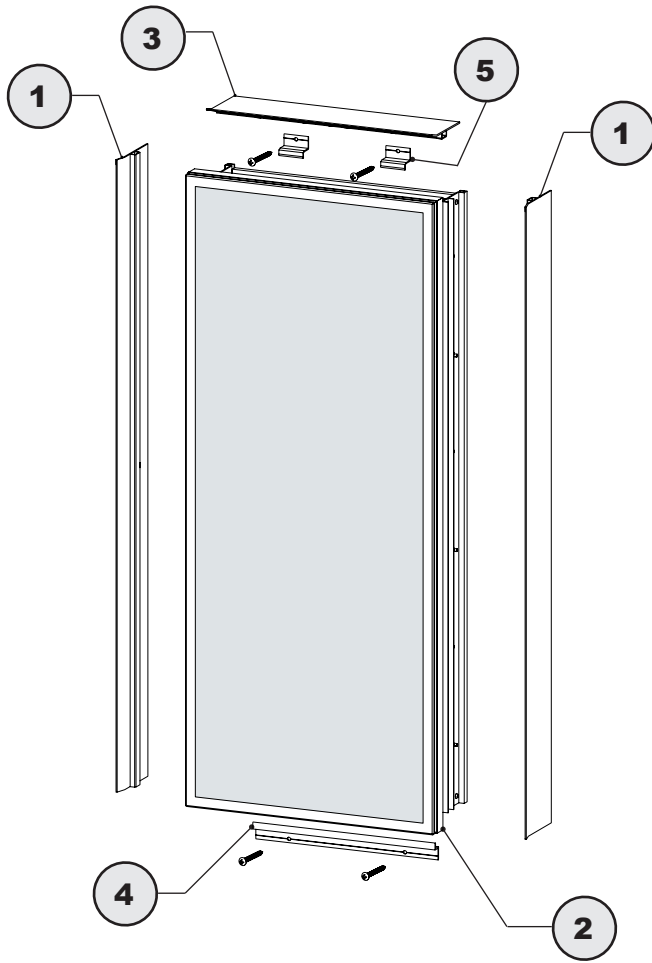

Reference image / Image de référence

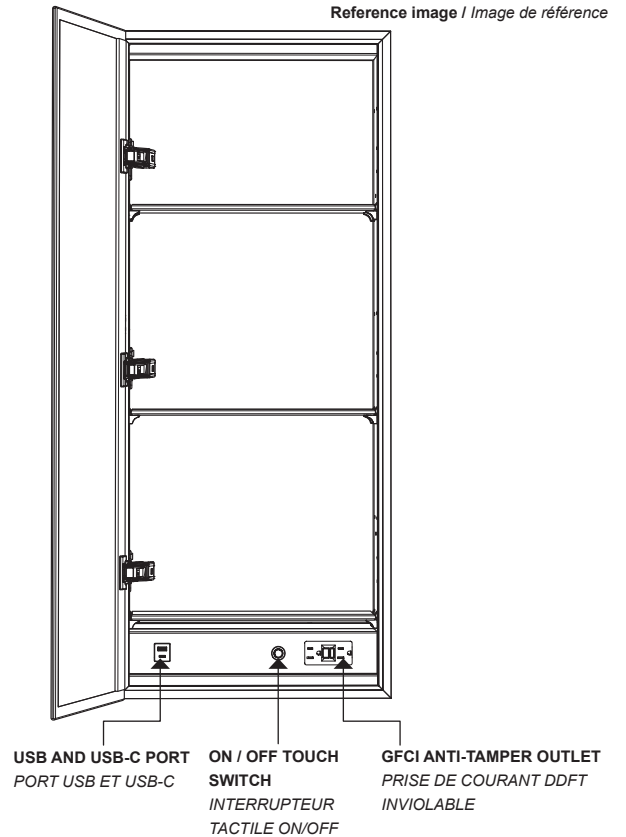

HARDWARE LISTING / LISTE DE QUINCAILLERIE

ITEM	PARTS LISTING / LISTE DES PIÈCES	QTY
1	SIDE PANEL / PANNEAU LATÉRAL	2
2	MIRROR CABINET / CABINET AVEC MIROIR	1
3	TOP PANEL / PANNEAU SUPÉRIEUR	1
4	BOTTOM SUPPORT / SUPPORT INFÉRIEUR	1
5	TOP BRACKET / SUPPORT SUPÉRIEUR	2
6	WALL PLUG / CHEVILLE	4
7	PAN HEAD SCREW (ST5-50MM) / VIS À TÊTE CYLINDRIQUE (ST5-50MM)	4
8	PAN HEAD SCREW (ST4-38MM) / VIS À TÊTE CYLINDRIQUE (ST4-38MM)	4
9	SCREW CAP / COUVRE-VIS	4
10	HOLE CAP / CACHE-TROUS	12
11	STICKER CAP / CACHE-TROU AUTOCOLLANT	10
12	SHELF SUPPORT PEG / SUPPORT DE TABLETTE	*4 PER SHELF 4 PAR TABLETTE
13A	HINGE PLATE / PLAQUE POUR CHARNIÈRE	*2 TO 3 PER DOOR 2 À 3 PAR PORTE
13B	HINGE / CHARNIÈRE	*2 TO 3 PER DOOR 2 À 3 PAR PORTE
13C	HINGE COVER / CACHE CHARNIÈRE	*2 TO 3 PER DOOR 2 À 3 PAR PORTE
14	GLASS SHELF / TABLETTE EN VERRE	*2 TO / À 4

*QUANTITY VARIES BY MODEL / QUANTITÉ VARIABLE SELON LE MODÈLE

FOR SURFACE MOUNTED INSTALLATION SEE PAGE 10

FOR RECESSED INSTALLATION SEE PAGE 23

POUR L'INSTALLATION SUSPENDUE VOIR LA PAGE 10

POUR L'INSTALLATION ENCASTRÉE VOIR LA PAGE 23

PARTS LISTING / LISTE DES PIÈCES

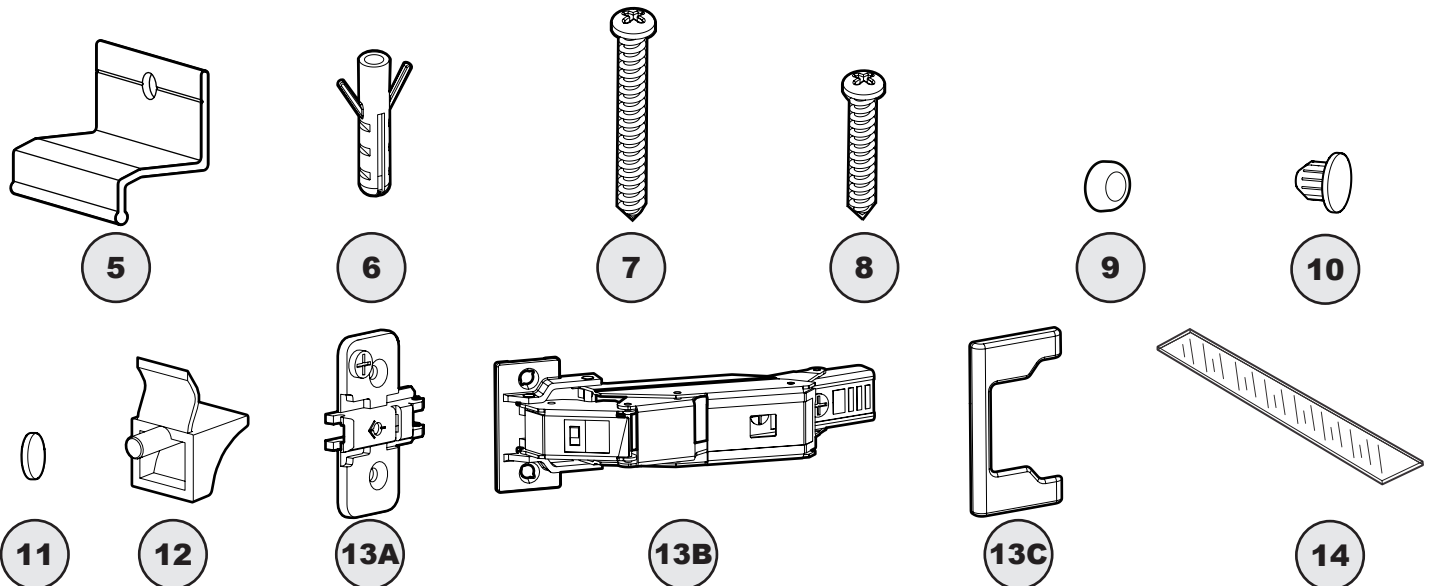

SINGLE DOOR MODEL, SIZE SPECIFICATIONS / MODÈLE À PORTE SIMPLE, DIMENSIONS

MODEL / MODÈLE	WIDTH / LARGEUR (W)	HEIGHT / HAUTEUR (H)
MCHS1930	19"	30 $\frac{3}{8}$ "
MCHS1936	19"	36 $\frac{3}{8}$ "
MCHS2430	24 $\frac{3}{8}$ "	30 $\frac{3}{8}$ "
MCHS2436	24 $\frac{3}{8}$ "	36 $\frac{3}{8}$ "

WALL MOUNTED / SUSPENDU

RECESSED / ENCASTRÉ

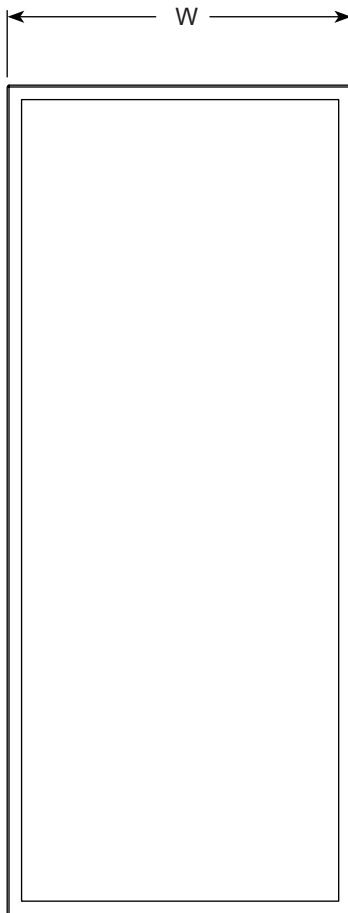

FRONT VIEW
VUE DE FACE

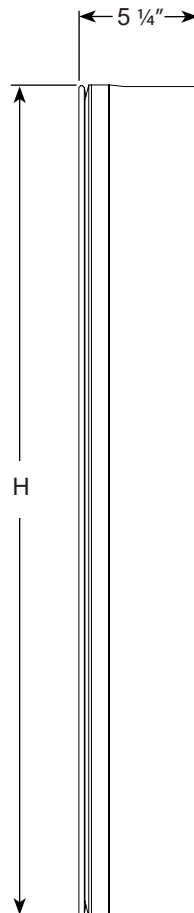

SIDE VIEW
VUE DE CÔTÉ

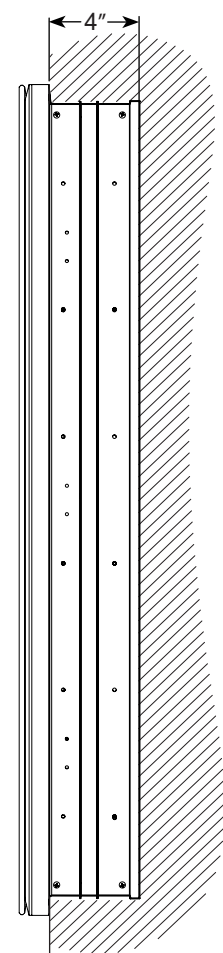

SIDE VIEW
VUE DE CÔTÉ

DOUBLE DOOR MODEL, SIZE SPECIFICATIONS / MODÈLE À PORTES DOUBLES, DIMENSIONS

MODEL / MODÈLE	WIDTH / LARGEUR (W)	HEIGHT / HAUTEUR (H)
MCHB3030	30 3/8"	30 3/8"
MCHB3036	30 3/8"	36 3/8"

WALL MOUNTED / SUSPENDU

RECESSED / ENCASTRÉ

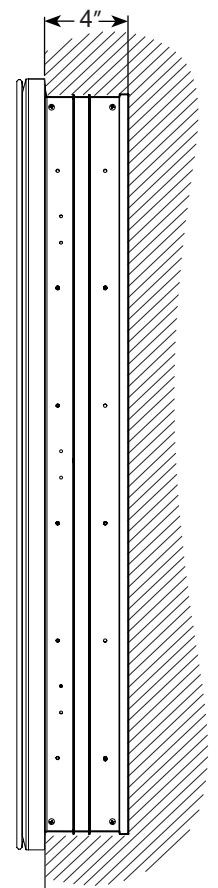
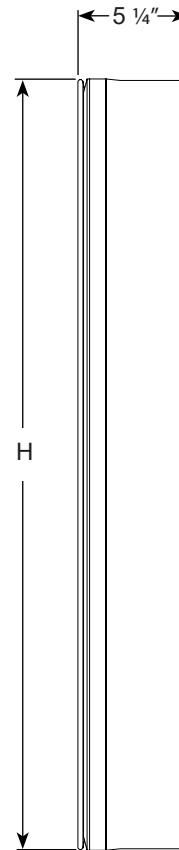
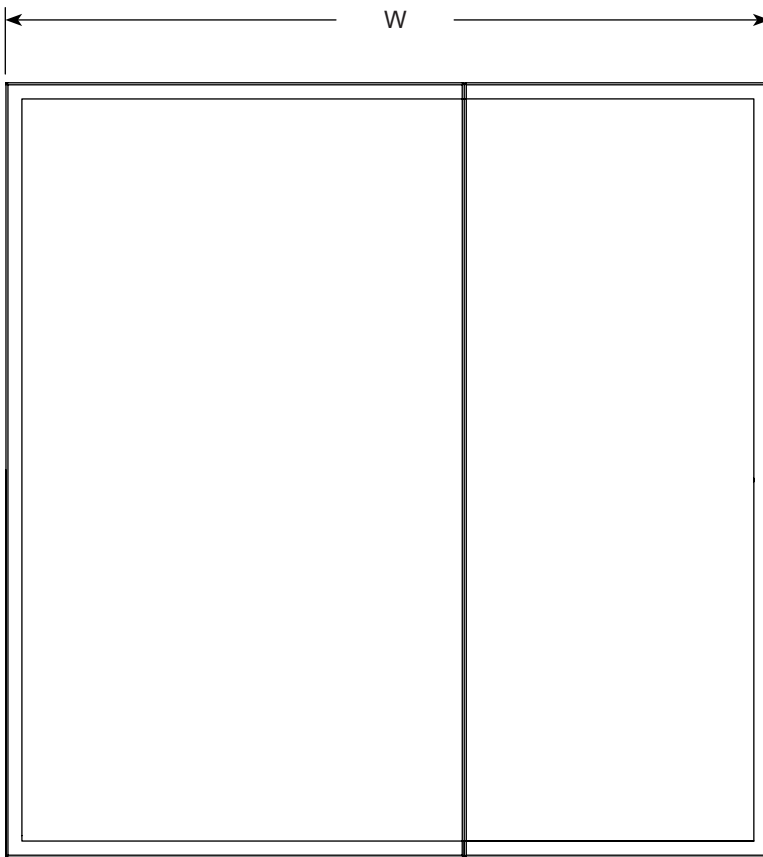

FRONT VIEW
VUE DE FACE

SIDE VIEW
VUE DE CÔTÉ

SIDE VIEW
VUE DE CÔTÉ

TRIPLE DOOR MODEL, SIZE SPECIFICATIONS / MODÈLE À PORTES TRIPLES, DIMENSIONS

MODEL / MODÈLE	WIDTH / LARGEUR (W)	HEIGHT / HAUTEUR (H)
MCHT3030	30 3/8"	30 3/8"
MCHT3036	30 3/8"	36 3/8"
MCHT3630	36 3/8"	30 3/8"
MCHT3636	36 3/8"	36 3/8"
MCHT4830	48 3/8"	30 3/8"
MCHT4836	48 3/8"	36 3/8"
MCHT6030	60"	30 3/8"
MCHT6036	60"	36 3/8"

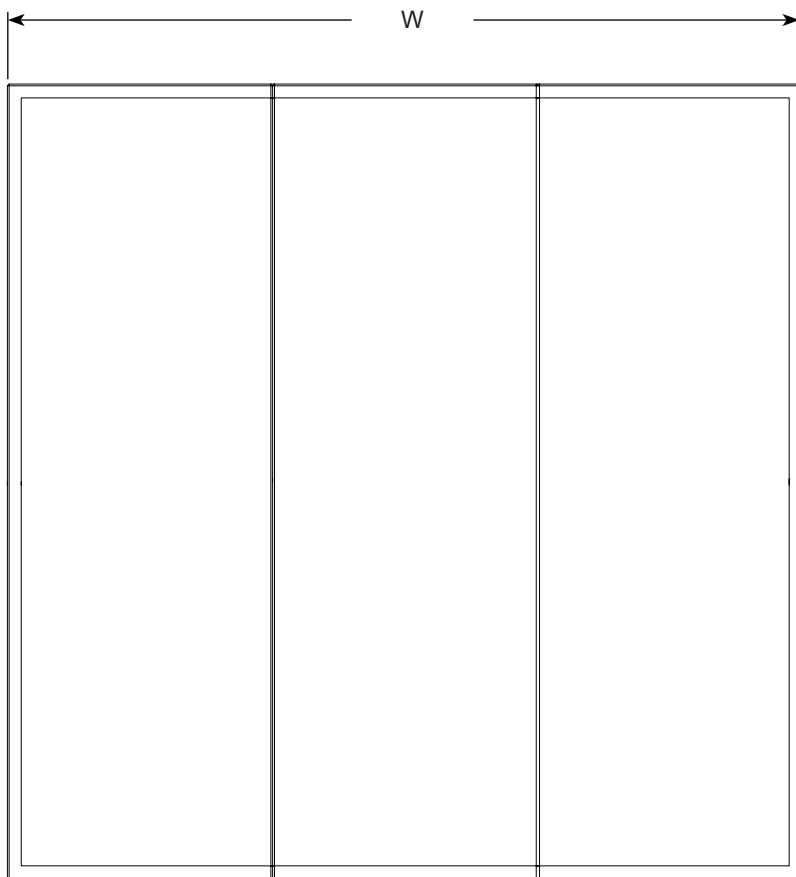

FRONT VIEW
VUE DE FACE

WALL MOUNTED / SUSPENDU

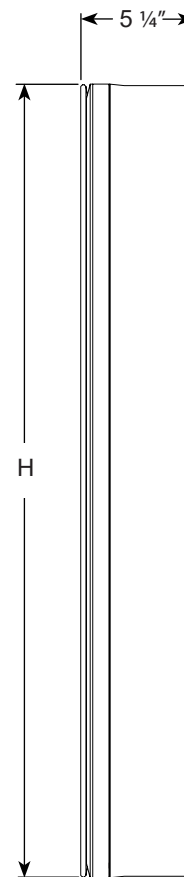

SIDE VIEW
VUE DE CÔTÉ

RECESSED / ENCASTRÉ

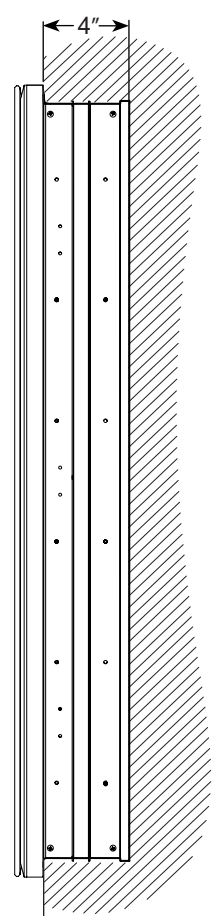

SIDE VIEW
VUE DE CÔTÉ

ELECTRICAL BOX PLACEMENT / EMPLACEMENT DU BOÎTIER ÉLECTRIQUE

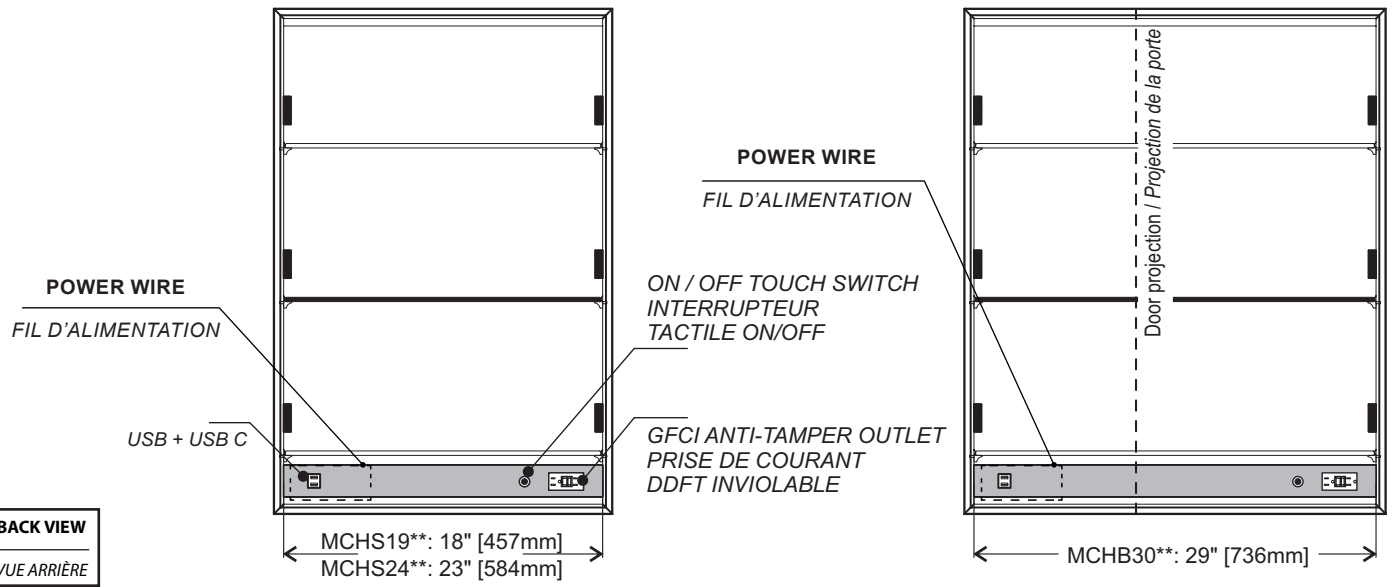

BACK VIEW
VUE ARRIÈRE

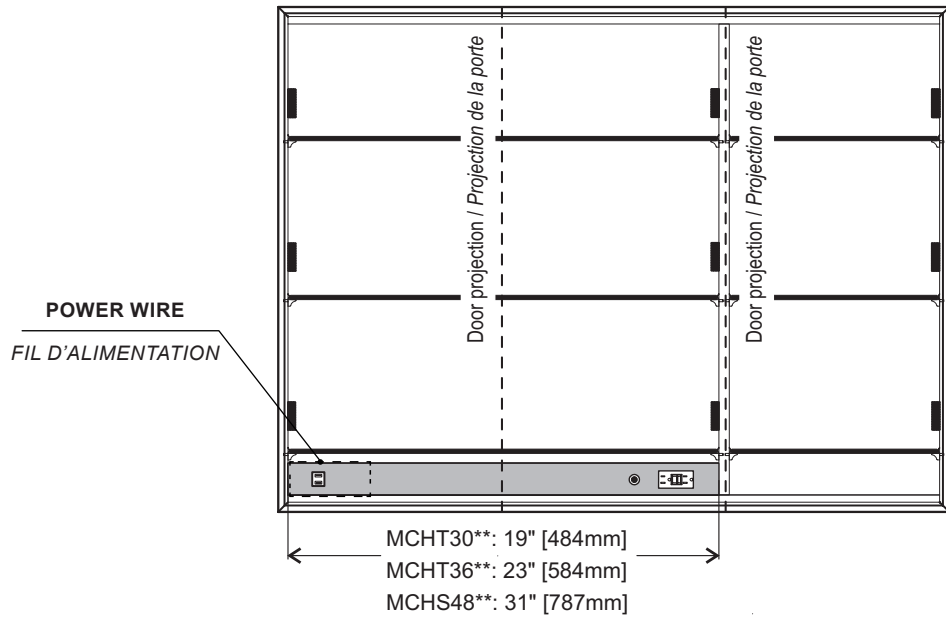
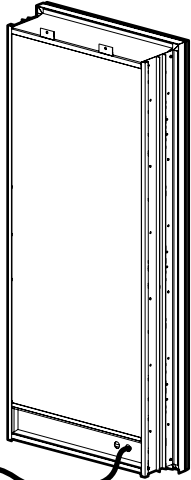

Hardwire this wire to junction box
Connecter ce câble au boîtier de raccordement

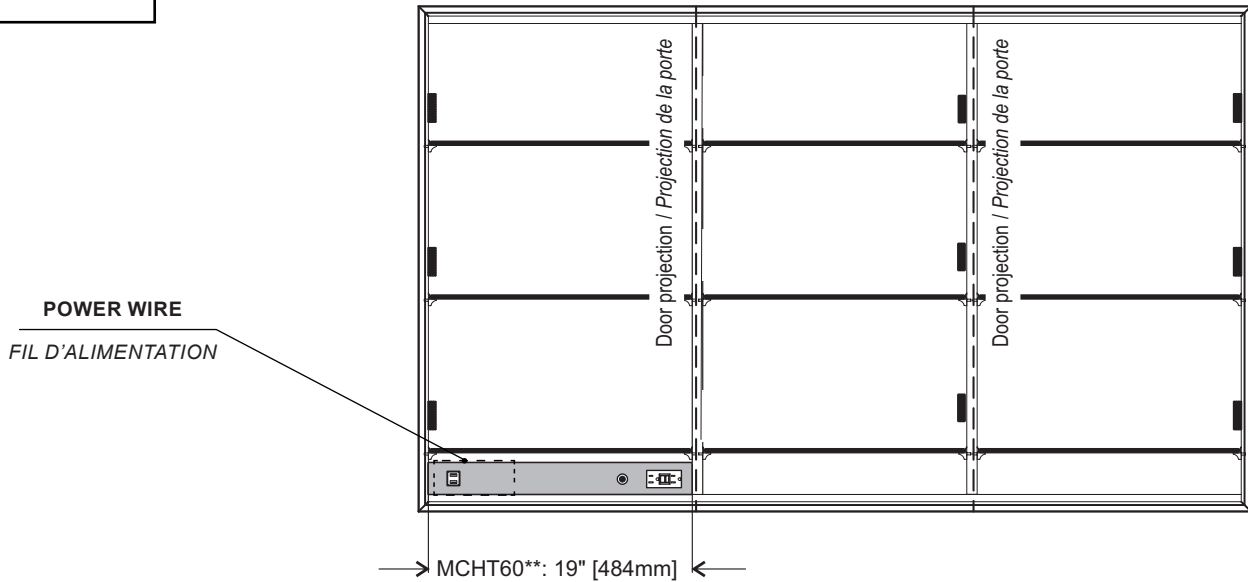

SURFACE MOUNT INSTALLATION / INSTALLATION SUSPENDUE

1 CABINET AND JUNCTION BOX POSITION EMPLACEMENT DU CABINET ET DU BOÎTIER DE RACCORDEMENT

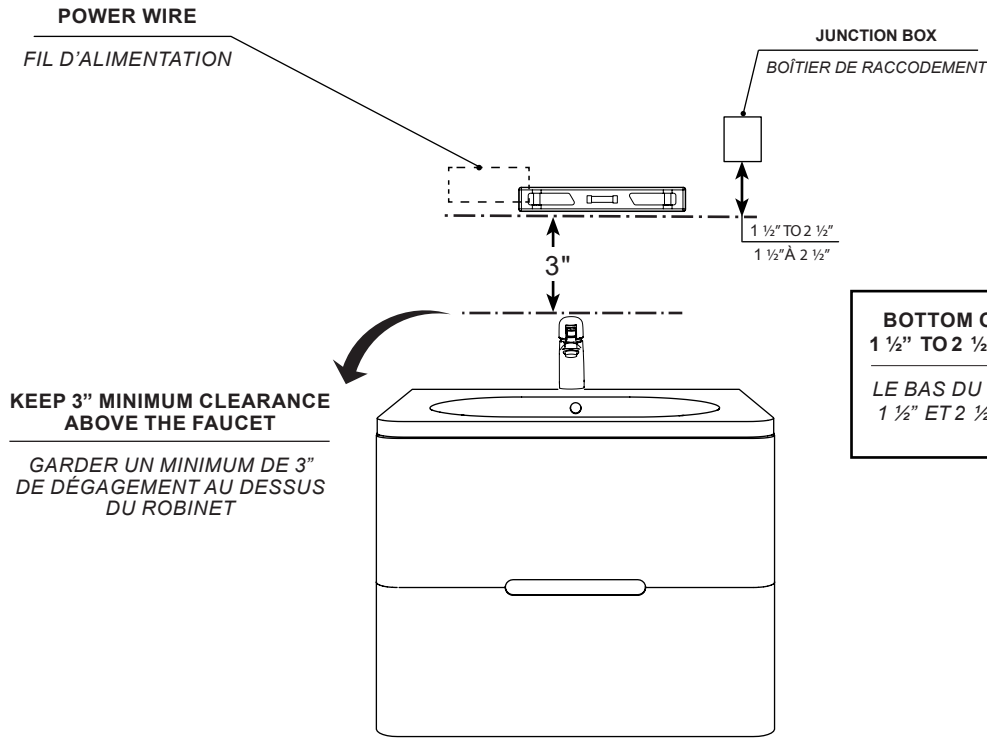

2 LEVEL AND MARK THE CABINET POSITION NIVELER ET MARQUER L'EMPLACEMENT DU CABINET

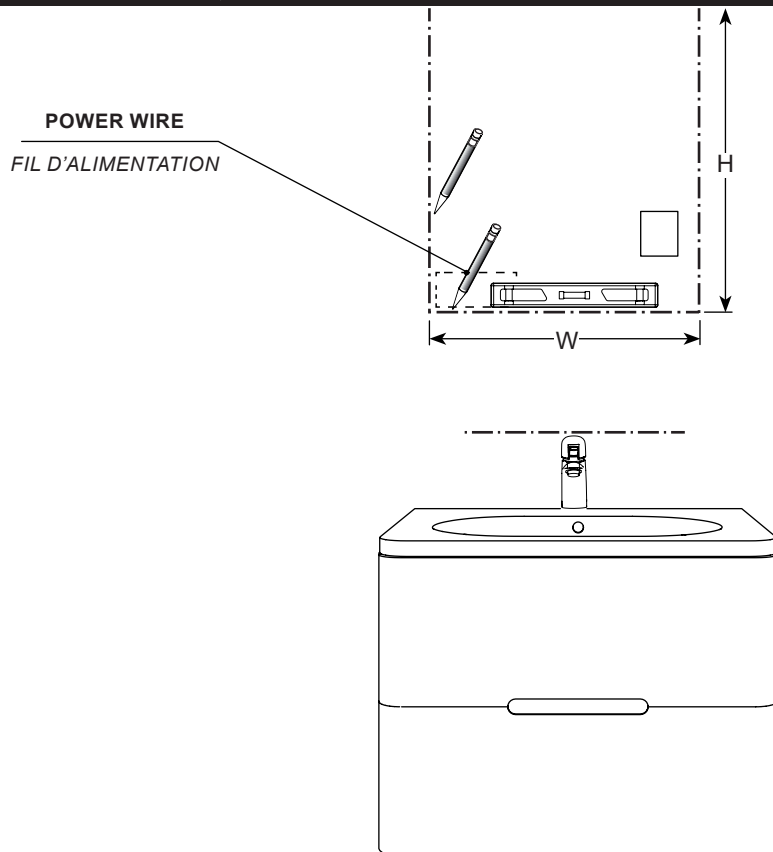

3

MARK THE BOTTOM SUPPORT HOLES ON THE WALL
MARQUER LES TROUS DU SUPPORT INFÉRIEUR SUR LE MUR

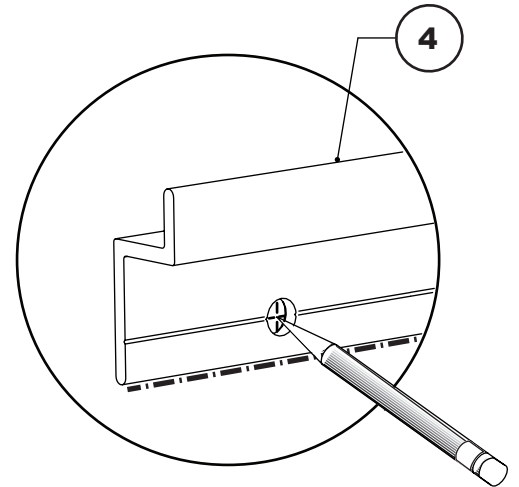
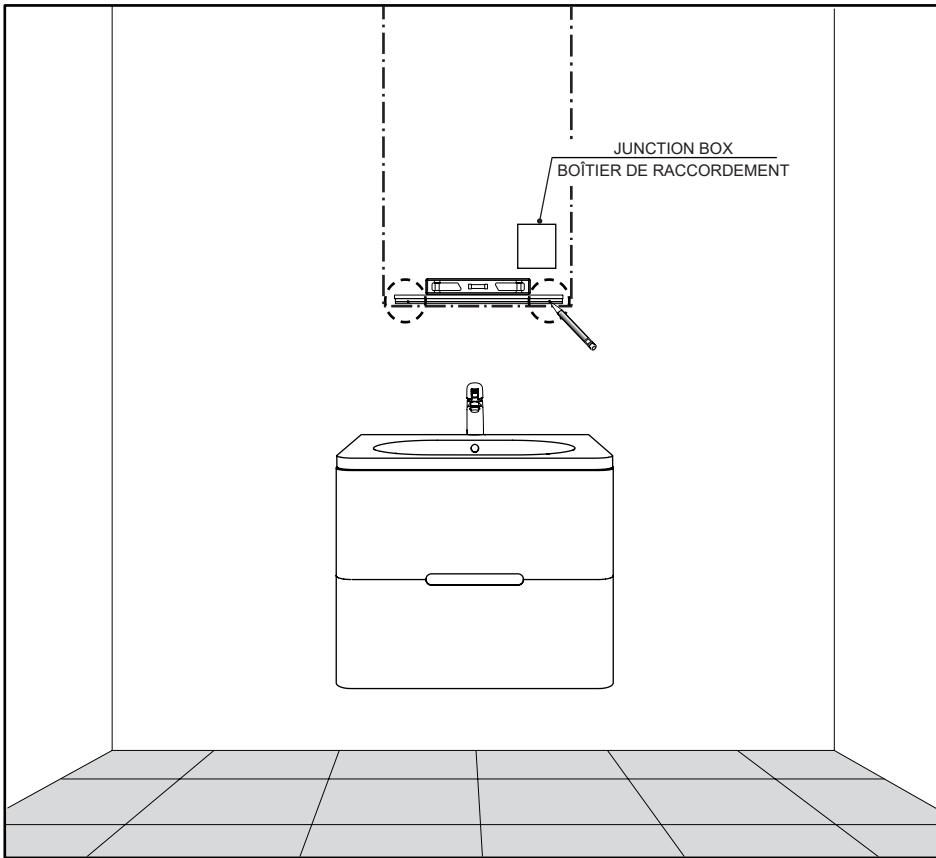

4

DRILL AND INSERT THE WALL PLUGS / PERCER ET INSÉRER LES CHEVILLES

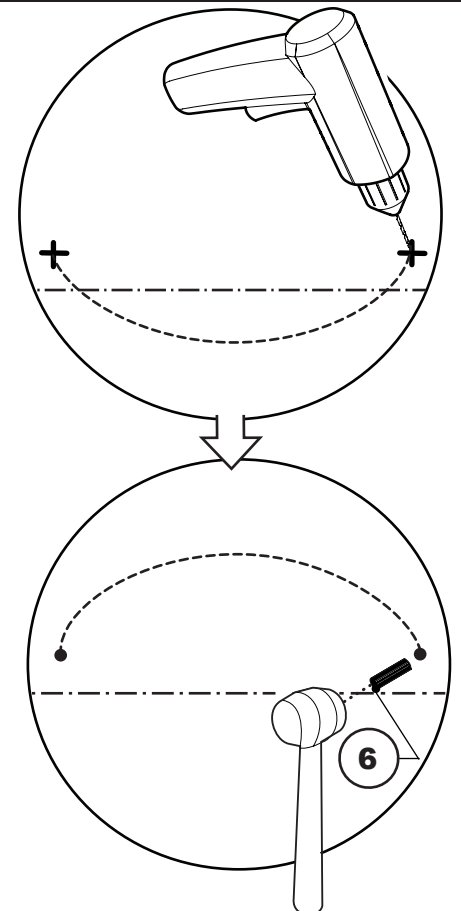
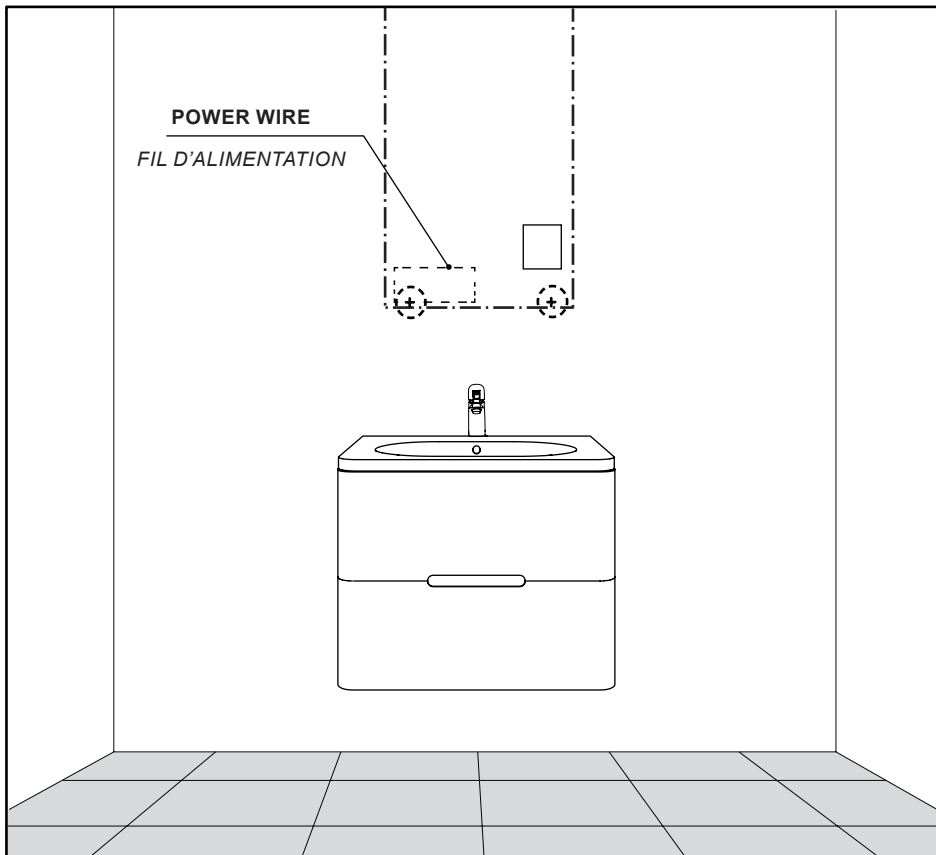

5

PLACE THE BOTTOM SUPPORT ON PREVIOUS MARK AND INSTALL
PLACER LE SUPPORT INFÉRIEUR SUR LES MARQUES FAITES PRÉCÉDEMMENT PUIS L'INSTALLER

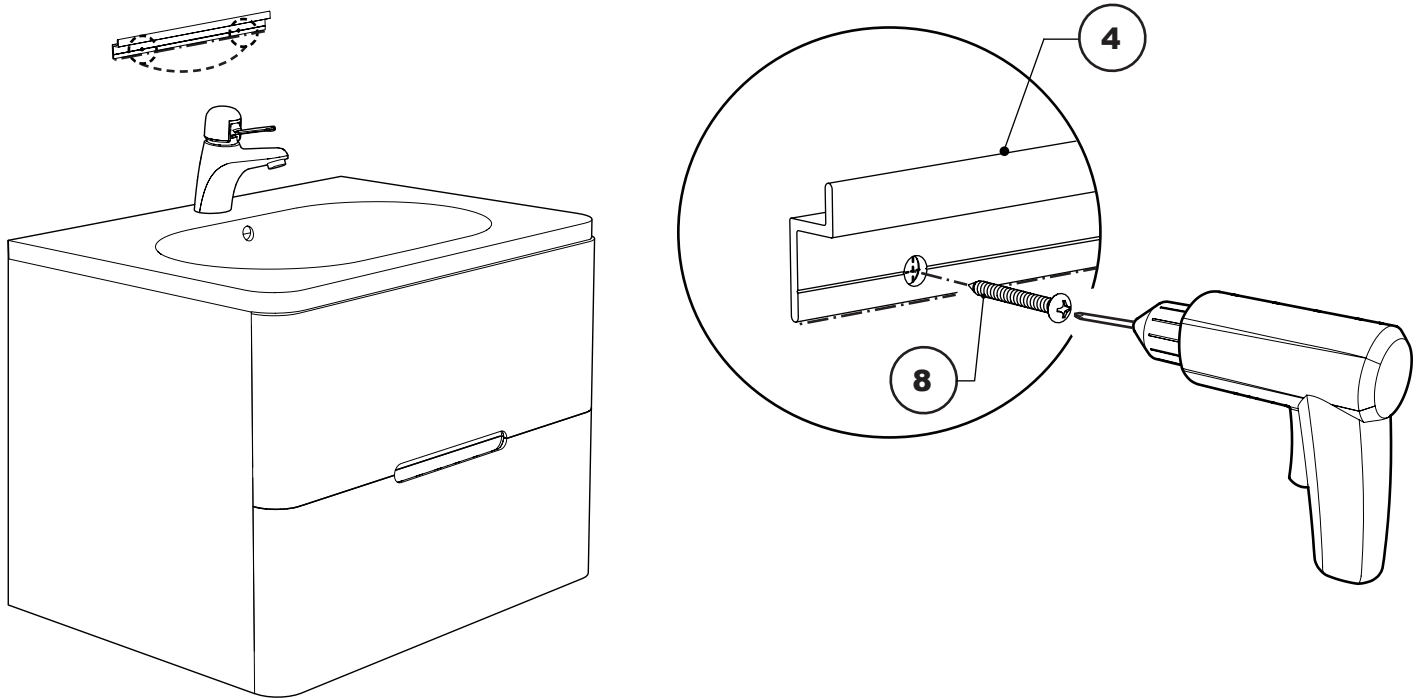

6

LOCATE THE STUDS IN THE WALL / LOCALISER LES MONTANTS DANS LE MUR

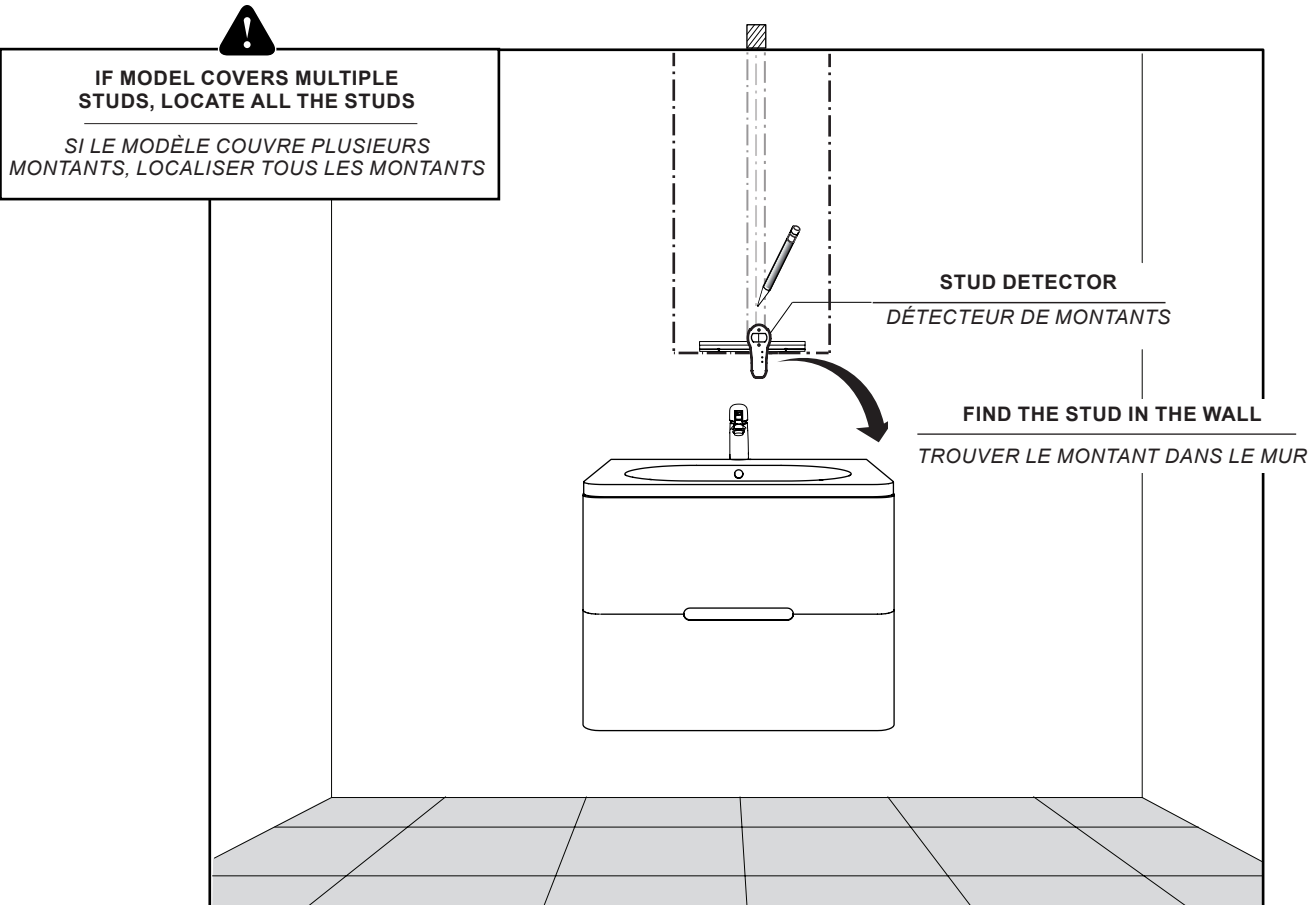

7

MARK THE STUD ON THE BOTTOM SUPPORT
MARQUER LE MONTANT SUR LE SUPPORT INFÉRIEUR



IF MODEL COVERS MULTIPLE STUDS, MARK ALL THE STUDS

SI LE MODÈLE COUVRE PLUSIEURS MONTANTS, MARQUER TOUS LES MONTANTS

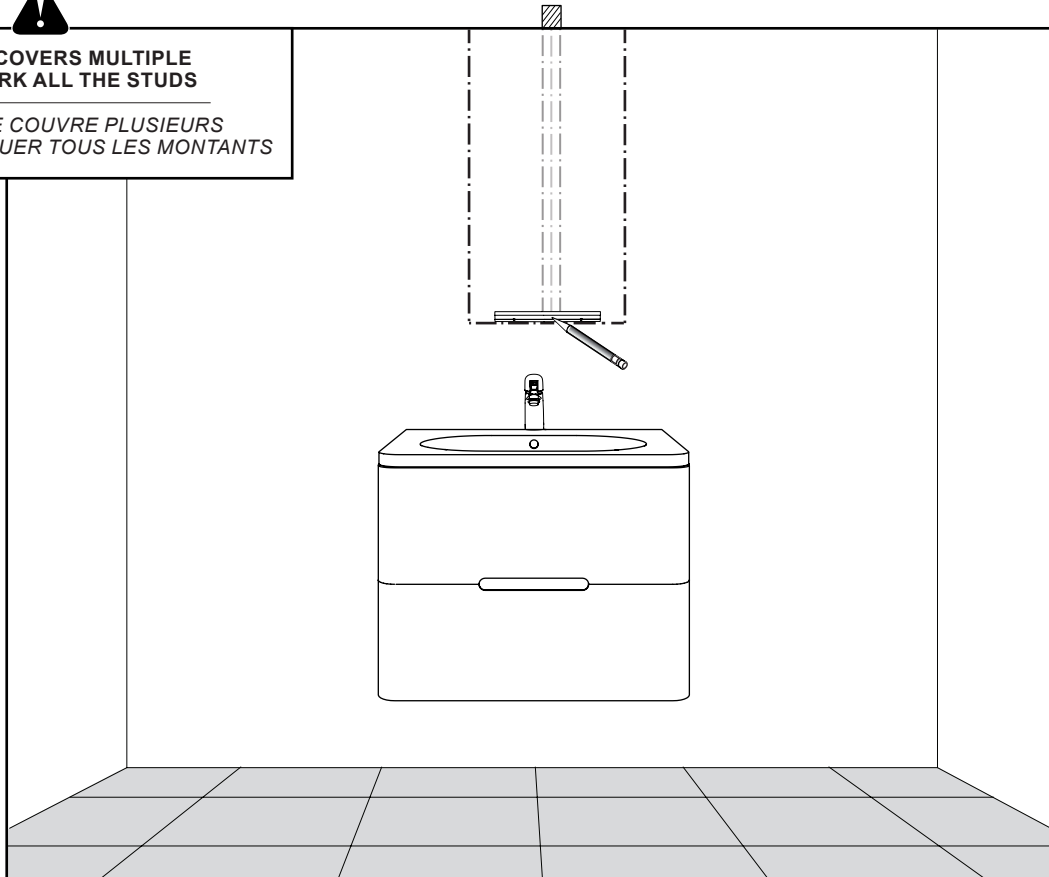

8

DRILL AND FASTEN THE BOTTOM SUPPORT ON THE STUD
PERCER ET SÉCURISER LE SUPPORT INFÉRIEUR SUR LE MONTANT

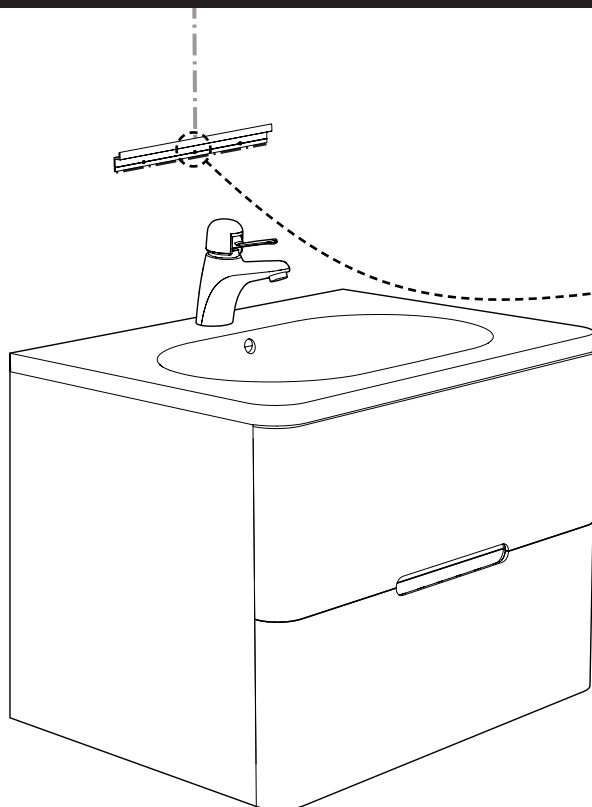

USE 3/32" DRILL BIT

UTILISER LA MÈCHE 3/32"

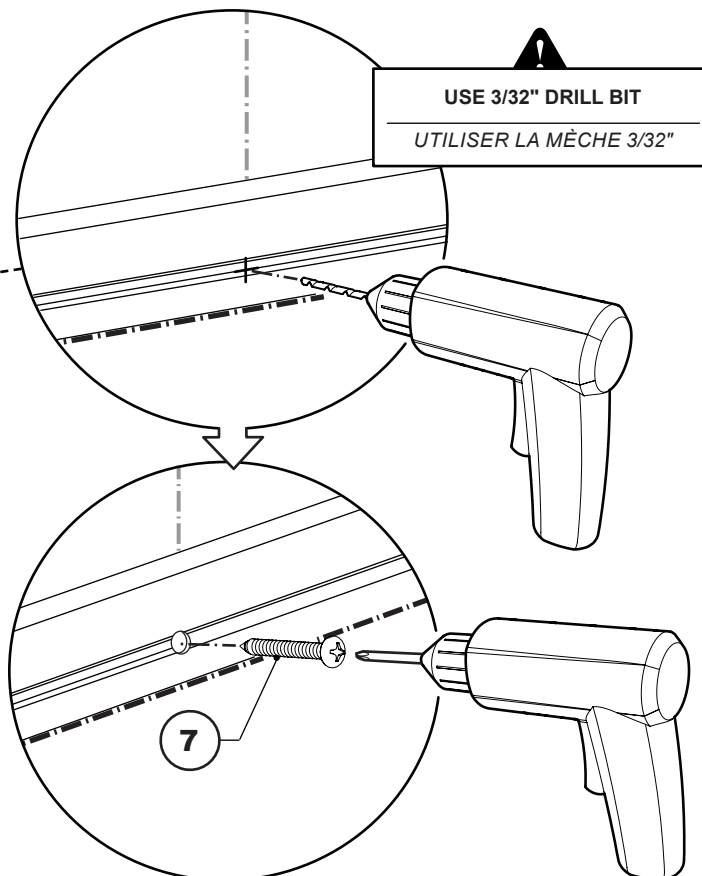

9 INSTALL THE HINGE PLATES / INSTALLER LES PLAQUES DE CHARNIÈRE

RIGHT SIDE INSTALLATION / INSTALLATION DU CÔTÉ DROIT

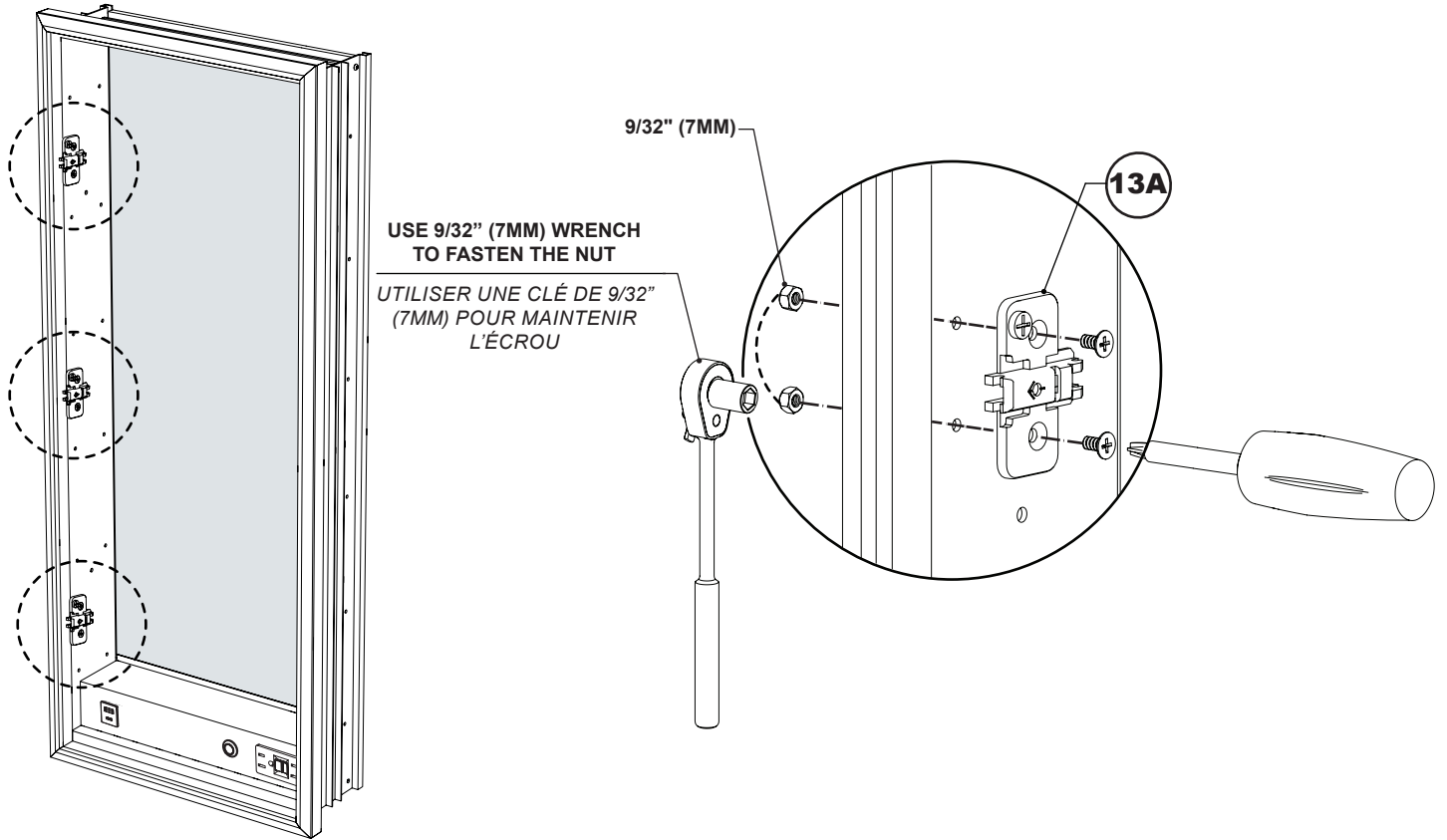

LEFT SIDE INSTALLATION / INSTALLATION DU CÔTÉ GAUCHE

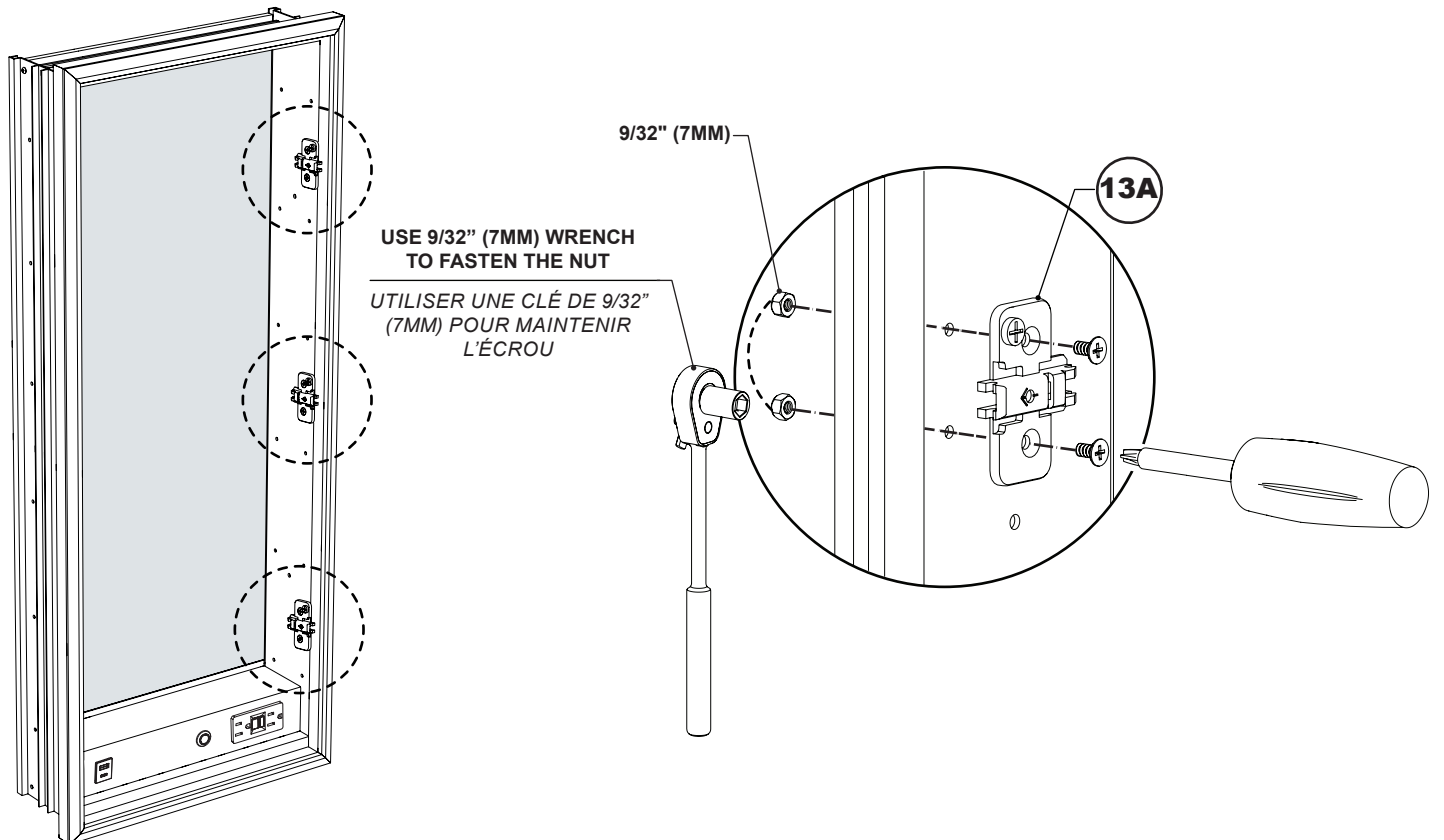

10 INSTALL THE TOP BRACKETS / INSTALLER LES SUPPORTS SUPÉRIEURS

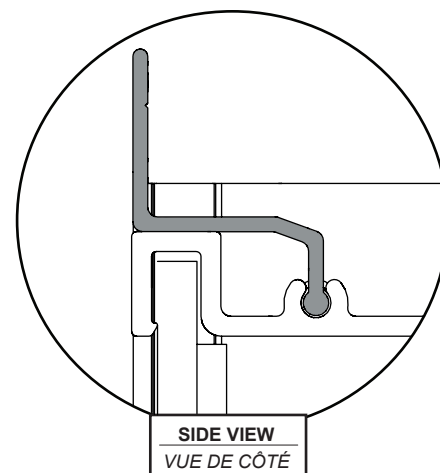
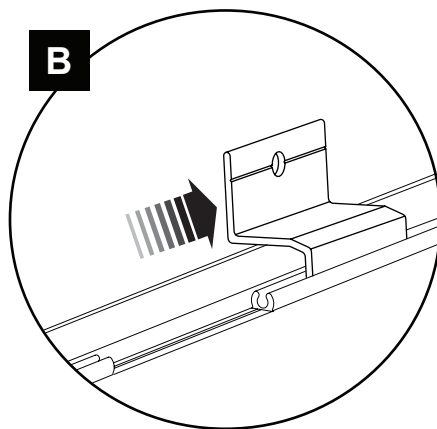
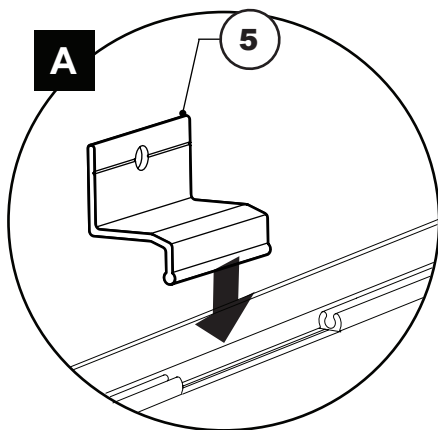
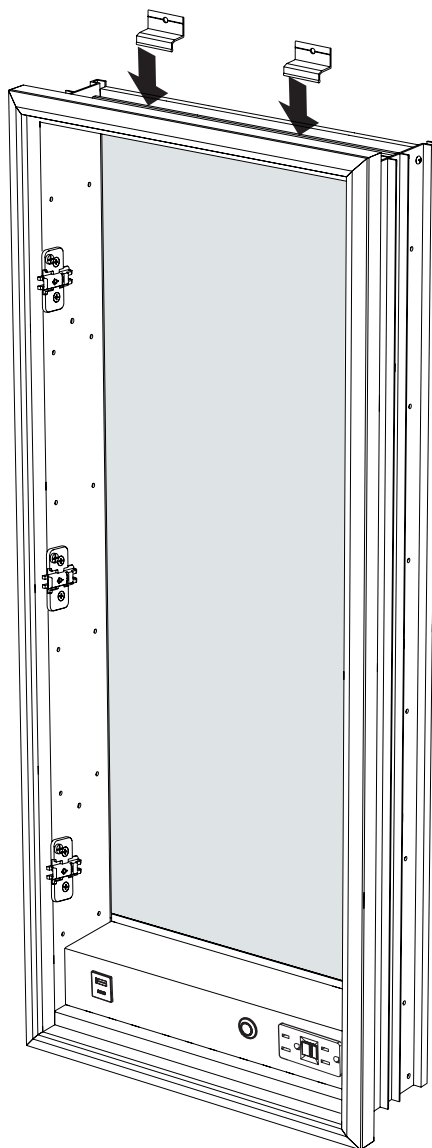

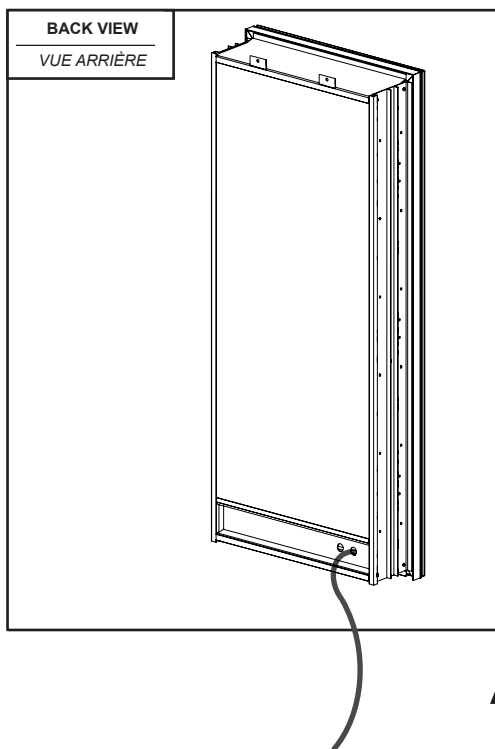

**AVERTISSEMENT
WARNING**

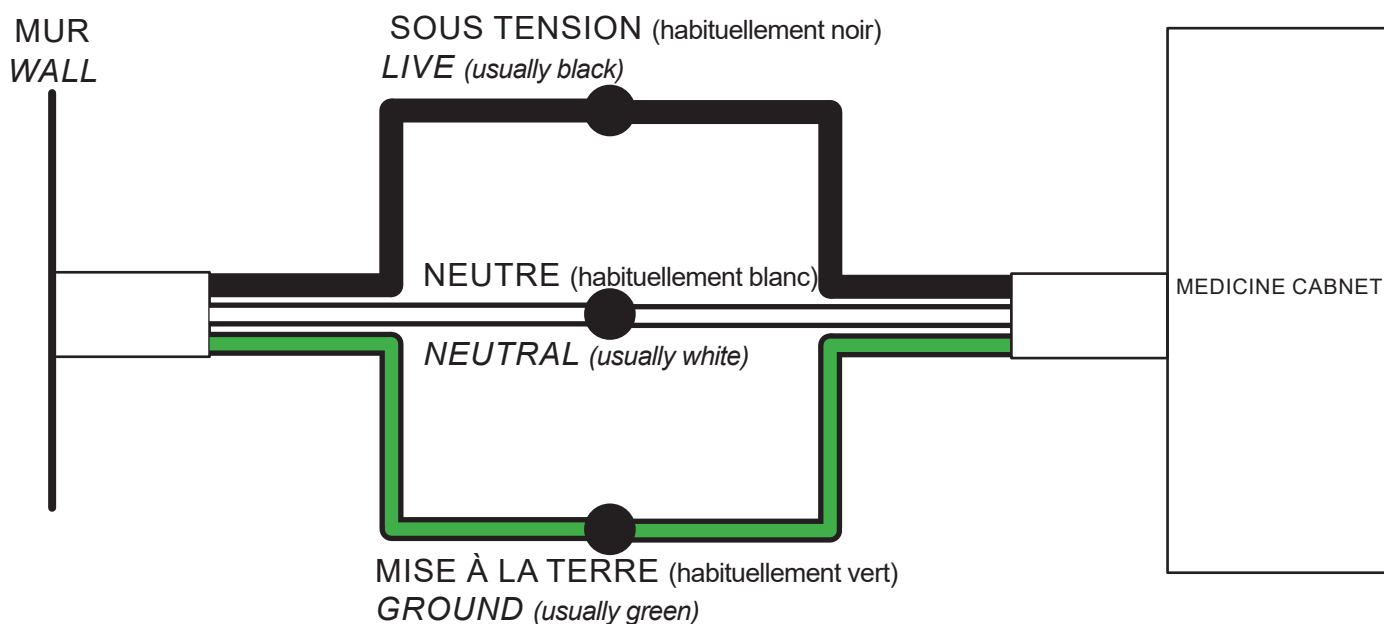

VEUILLEZ NOTER: Les couleurs présentées dans le diagramme ci-dessus sont basées sur un système standardisé. Elles peuvent varier selon votre système électrique. Pour tout doute sur la connexion, veuillez vous référer à un électricien professionnel qualifié. Fleurco n'est pas responsable des conséquences d'un mauvais raccordement électrique pouvant mener à des chocs électriques, au feu et à la mort.

PLEASE NOTE: The colors referenced in the diagram above is based on conventional standards and may differ between households. If there is any confusion as to how these should be connected, please seek the help of a licensed professional electrician. Electric shock, fire hazard and death are possible consequences of poor wiring for none of which Fleurco will be held liable.

12

PLACE THE CABINET ON THE WALL / PLACER LE CABINET SUR LE MUR

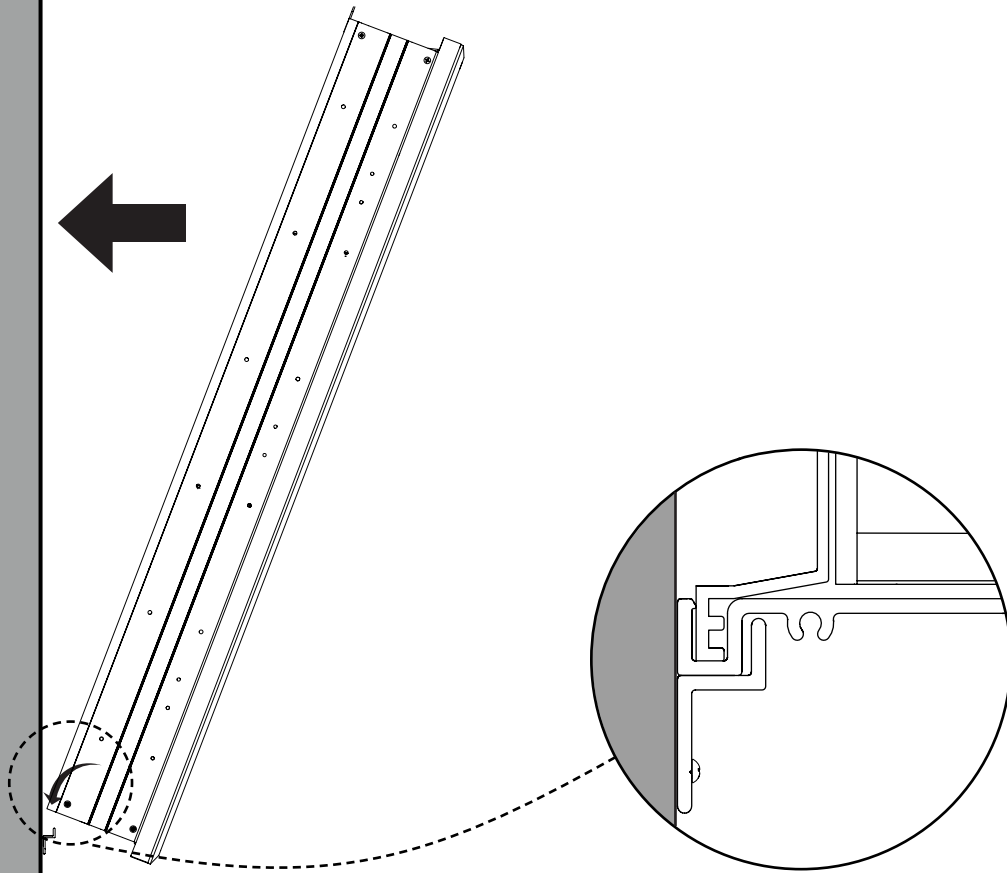

13

ADJUST THE BRACKETS AND FASTEN / AJUSTER ET SÉCURISER LES SUPPORTS

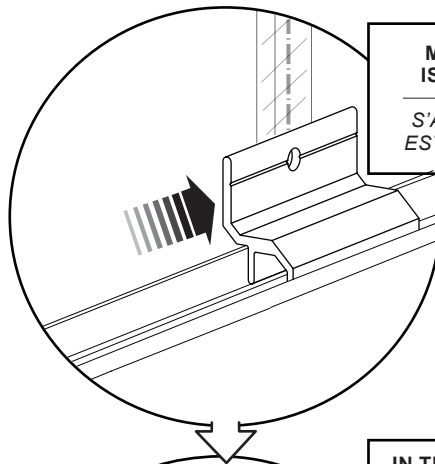
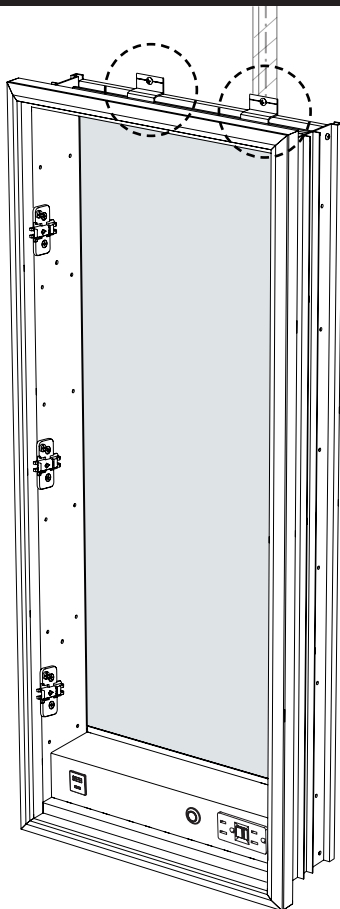

!
MAKE SURE THE BRACKET IS ALIGNED WITH THE STUD
S'ASSURER QUE LE SUPPORT EST ALIGNÉ AVEC LE MONTANT

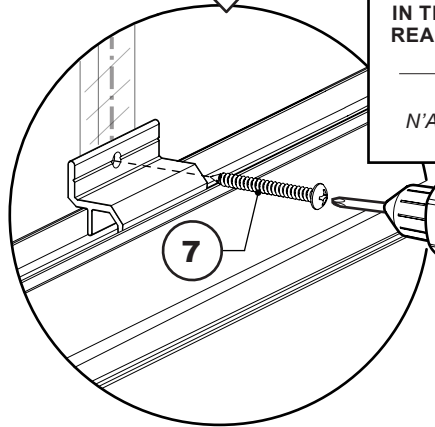

!
IN THE CASE WHERE BRACKET DOESN'T REACH THE STUD USE A WALL PLUG AND SCREW #8
DANS LE CAS OÙ LE SUPPORT N'ATTEINT PAS LE MONTANT, UTILISER UNE CHEVILLE ET UNE VIS #8

14 INSTALL THE HINGES / INSTALLER LES CHARNIÈRES

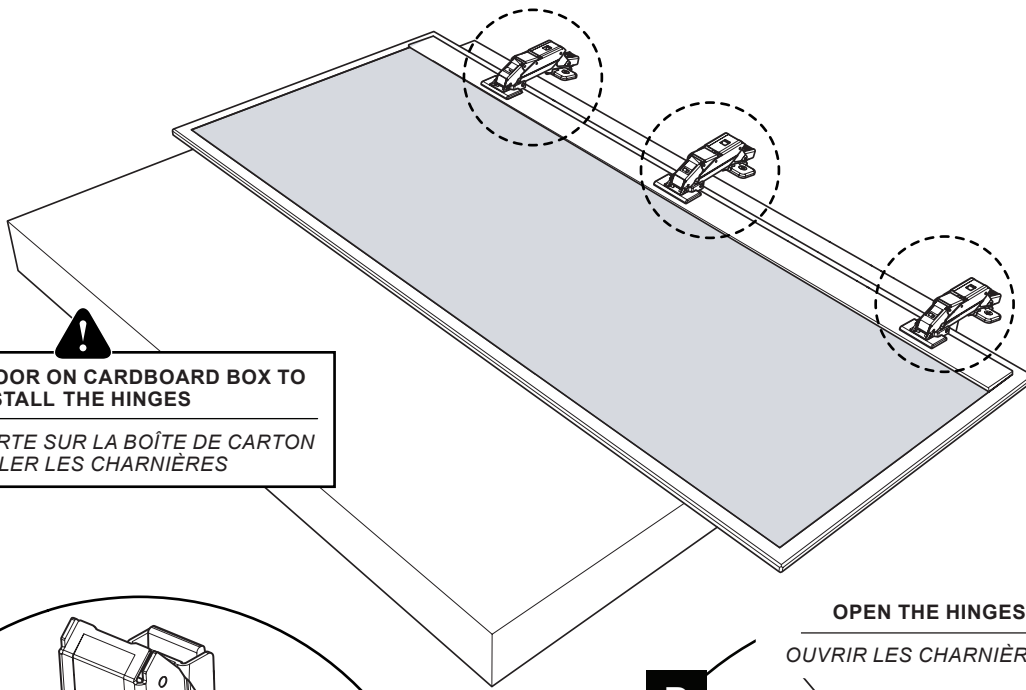

!
PLACE THE DOOR ON CARDBOARD BOX TO
INSTALL THE HINGES
PLACER LA PORTE SUR LA BOÎTE DE CARTON
POUR INSTALLER LES CHARNIÈRES

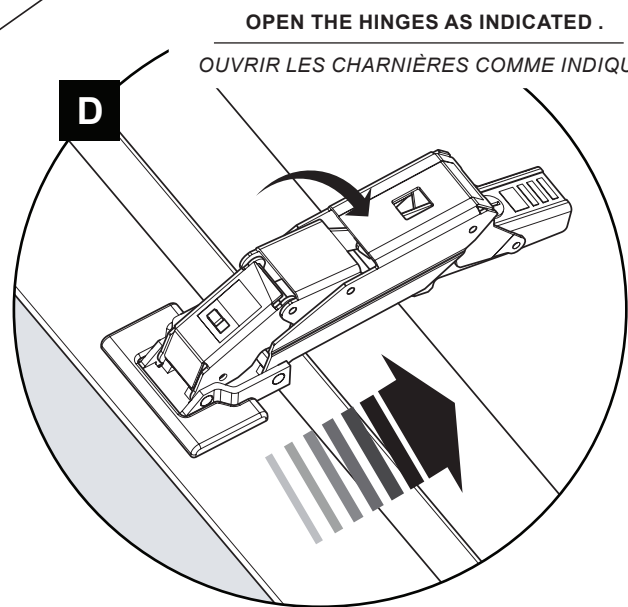
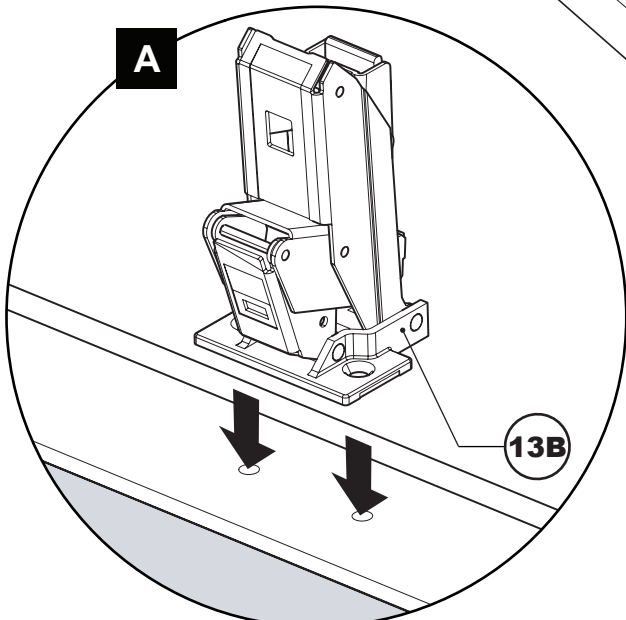

OPEN THE HINGES AS INDICATED .
OUVRIR LES CHARNIÈRES COMME INDiqué.

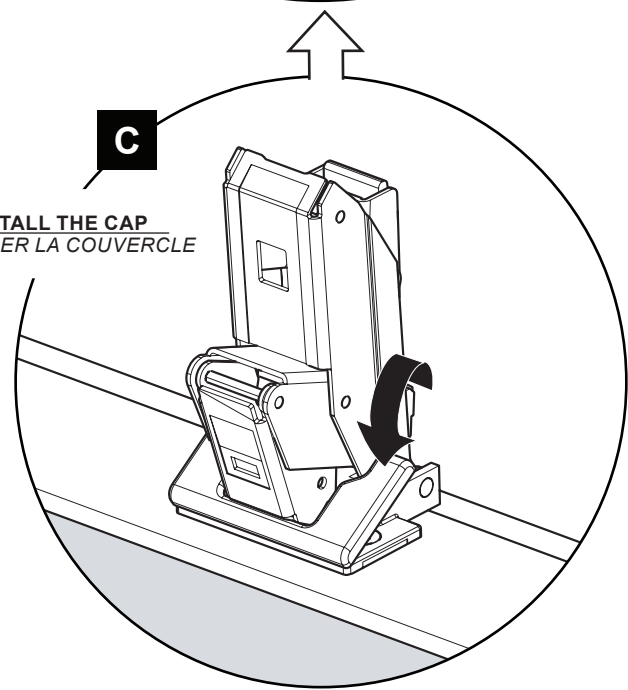
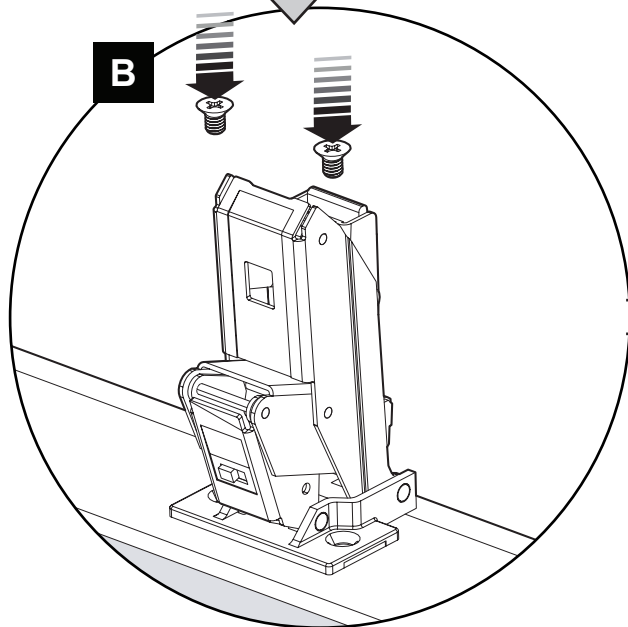

INSTALL THE CAP
INSTALLER LA COUVERCLE

15 INSTALL THE DOOR / INSTALLER LA PORTE

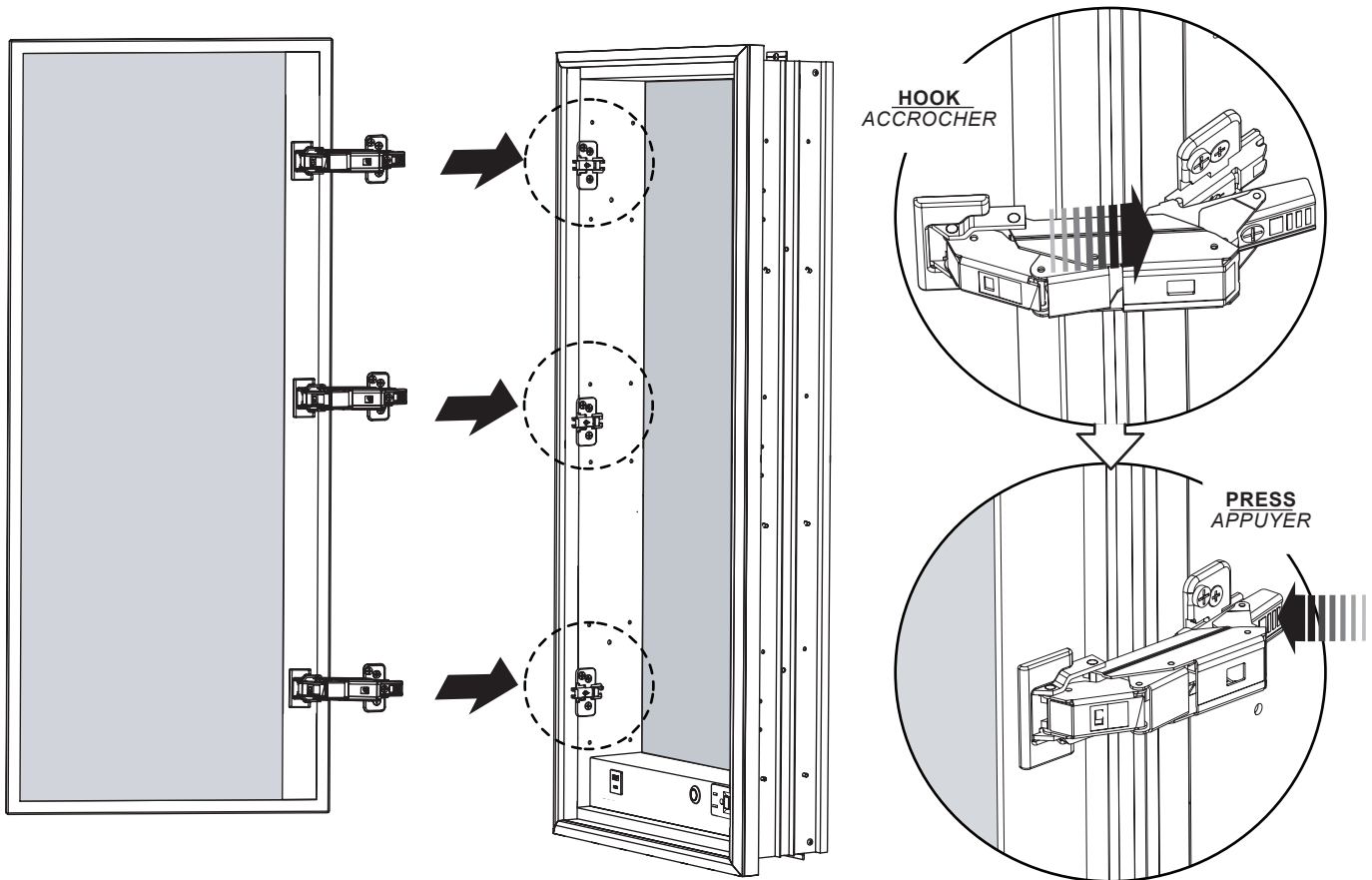

16 INSTALL THE SIDE PANELS / INSTALLER LES PANNEAUX DE LATÉRAUX

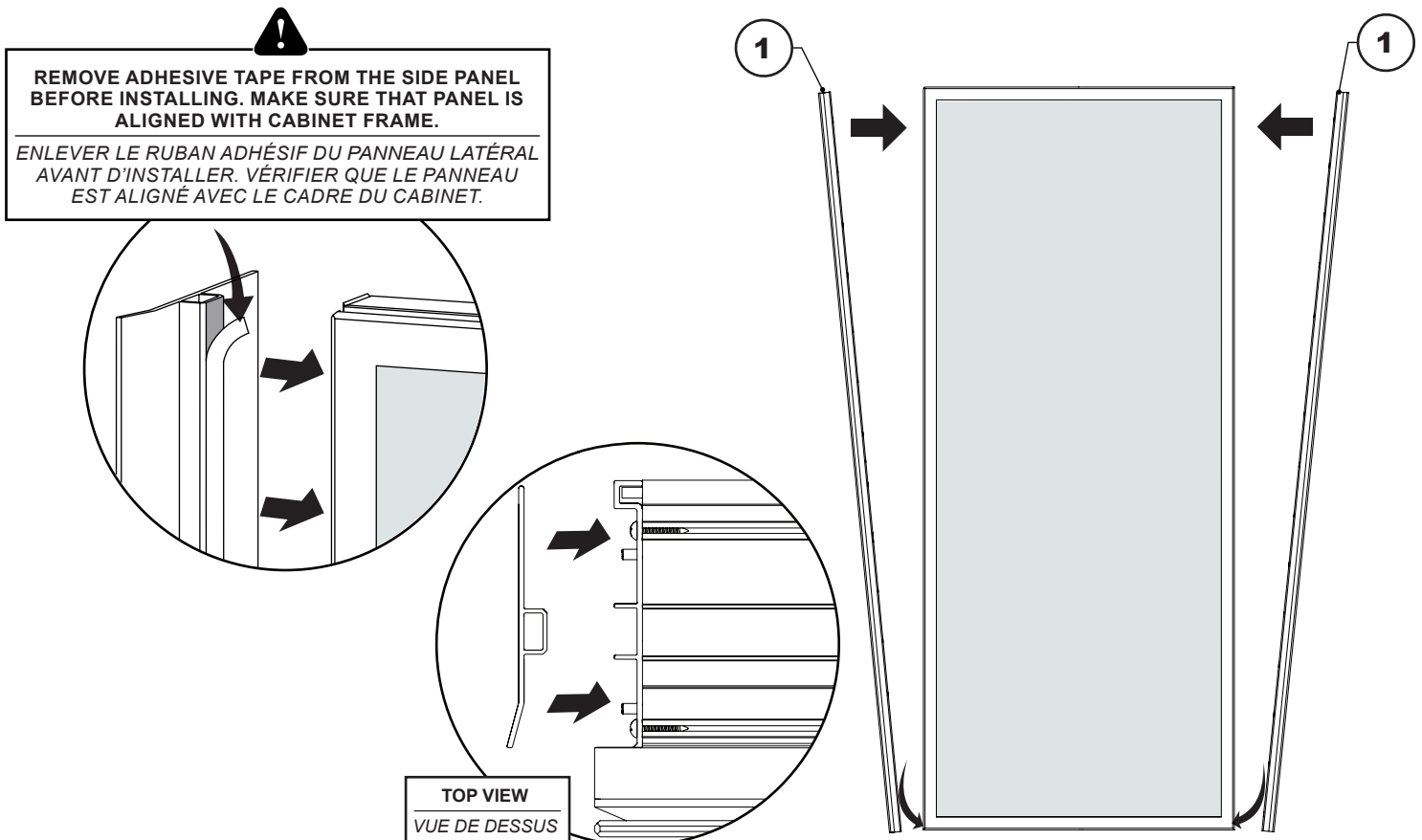

17 PLACE THE TOP PANEL / PLACER LE PANNEAU SUPÉRIEUR

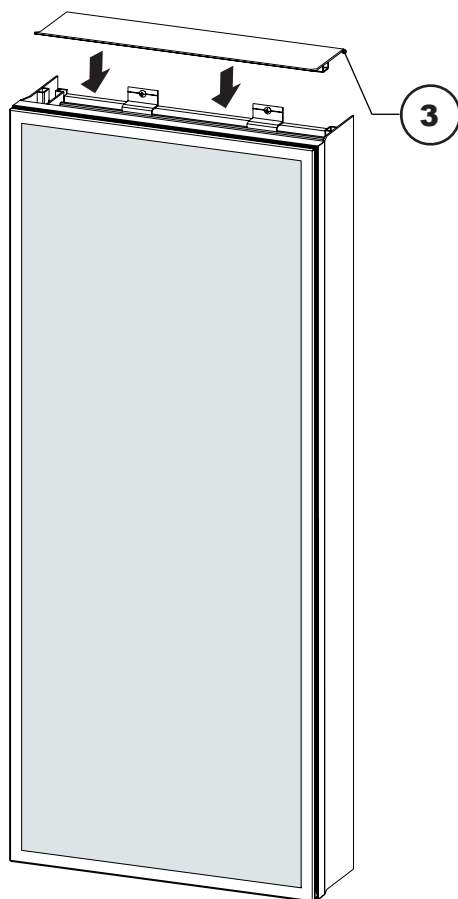

18 INSTALL THE SHELF SUPPORT PEGS / INSTALLER LES SUPPORTS DE TABLETTE

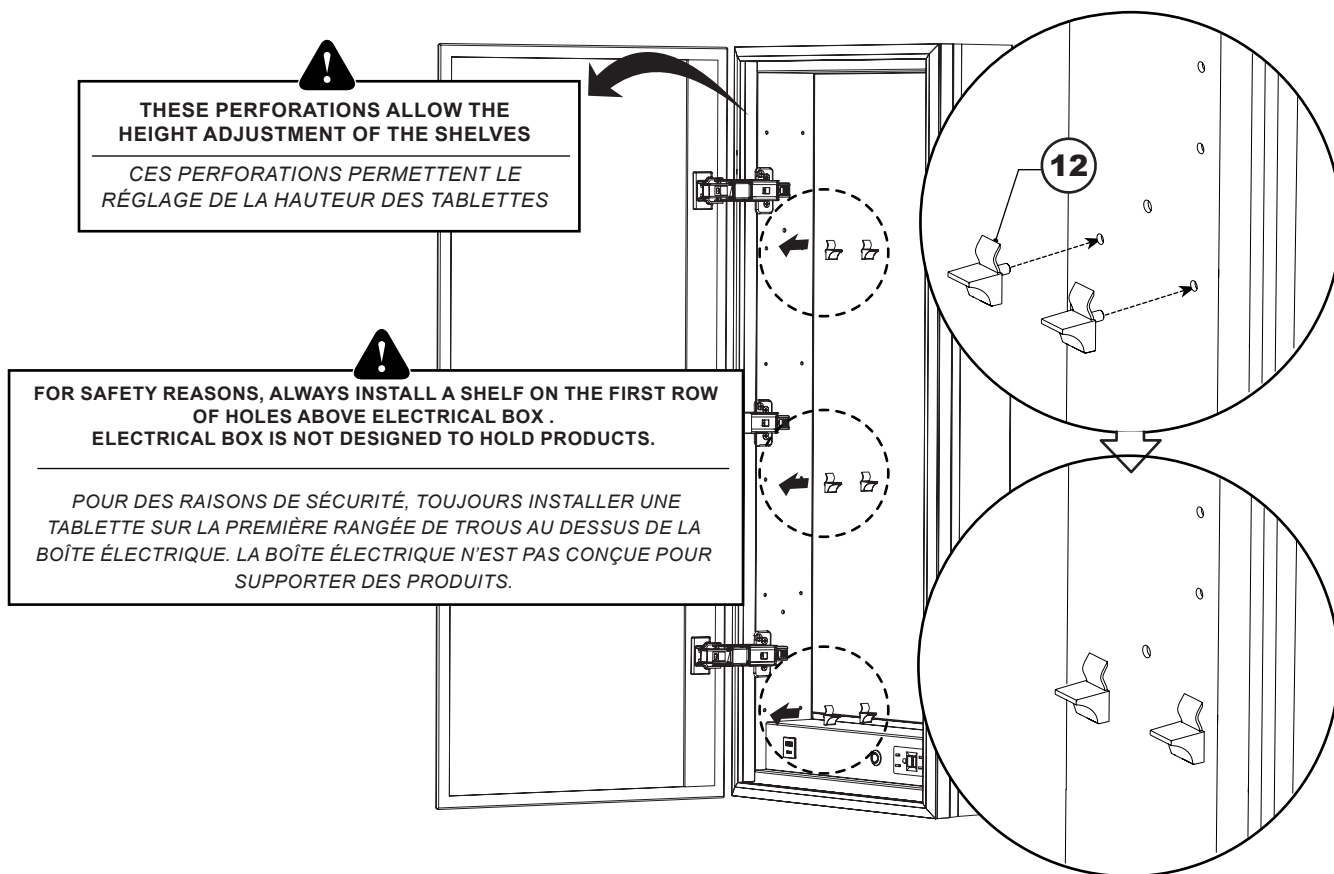

19 INSTALL THE GLASS SHELVES / INSTALLER LES TABLETTES EN VERRE

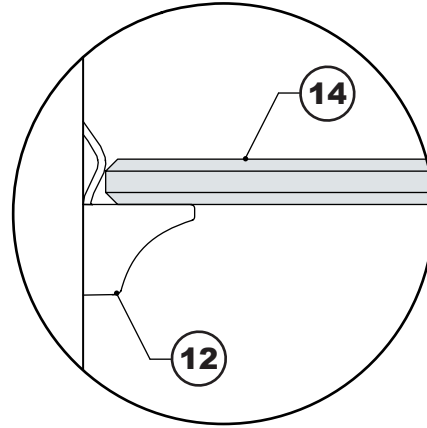
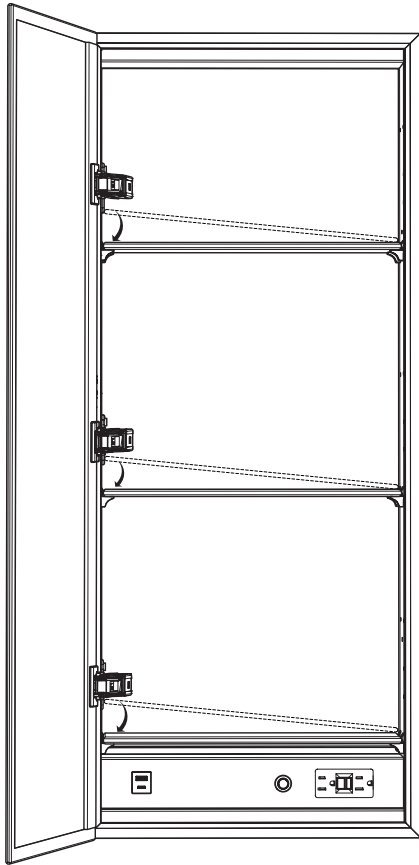

20 INSTALL THE HOLE CAPS / INSTALLER LES CACHE-TROUS

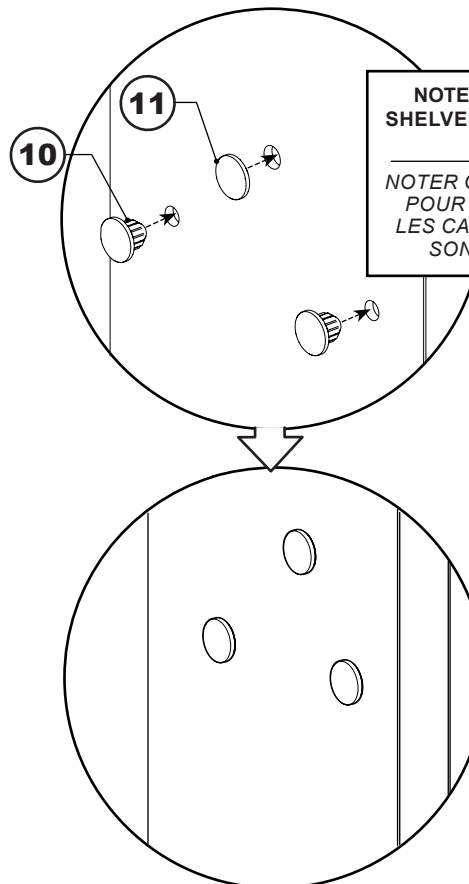
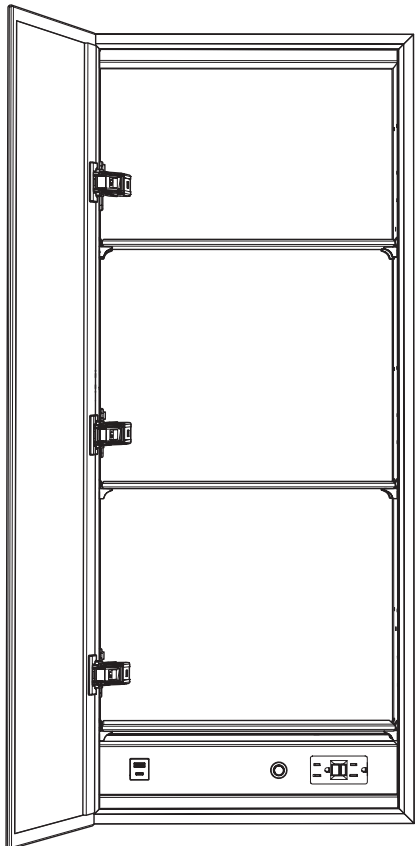

!
NOTE THAT HOLE CAPS #10 ARE FOR SHELVES HOLES AND ADHESIVE CAPS #11 ARE FOR OTHER HOLES.
NOTER QUE LES CACHE-TROUS #10 SONT POUR LES TROUS DES TABLETTES ET LES CACHE-TROUS AUTOCOLLANTS #11 SONT POUR LES AUTRES TROUS.

21 ADJUST THE DOOR / AJUSTER LA PORTE

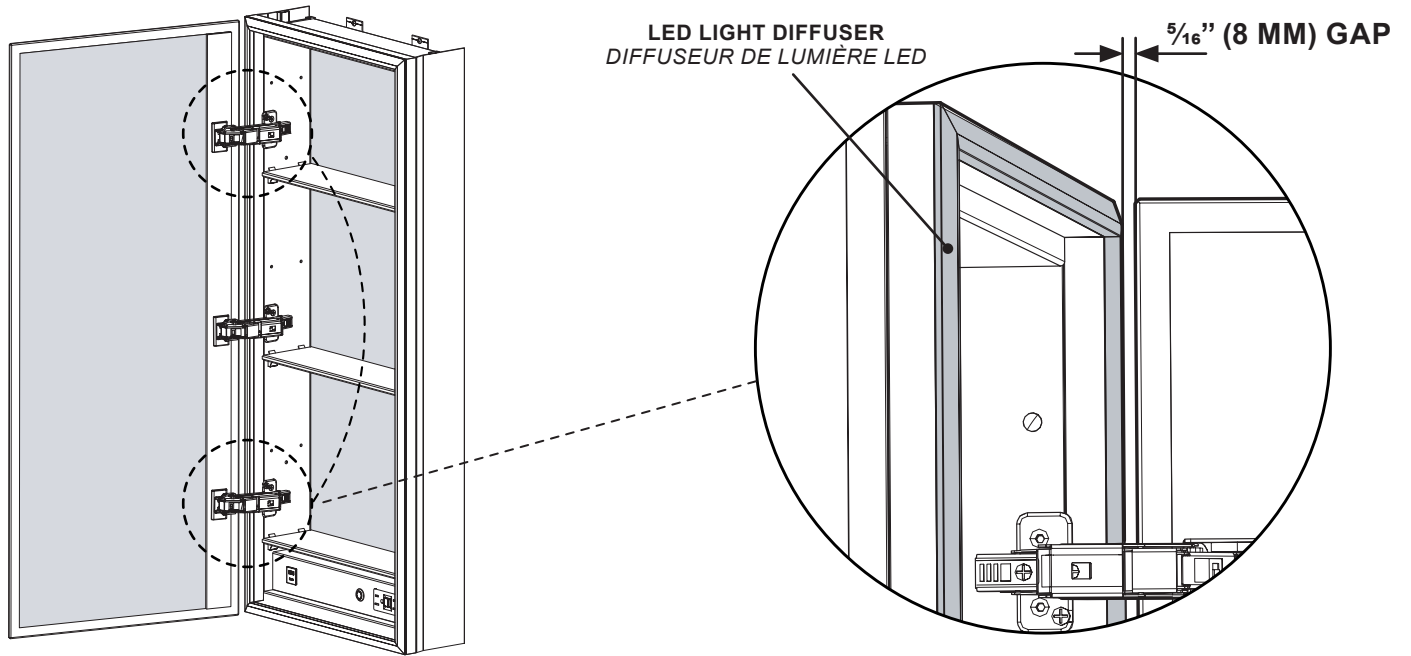

A ADJUST THE GAP BETWEEN DOOR AND CABINET / AJUSTER L'ESPACE ENTRE LA PORTE ET LE CABINET

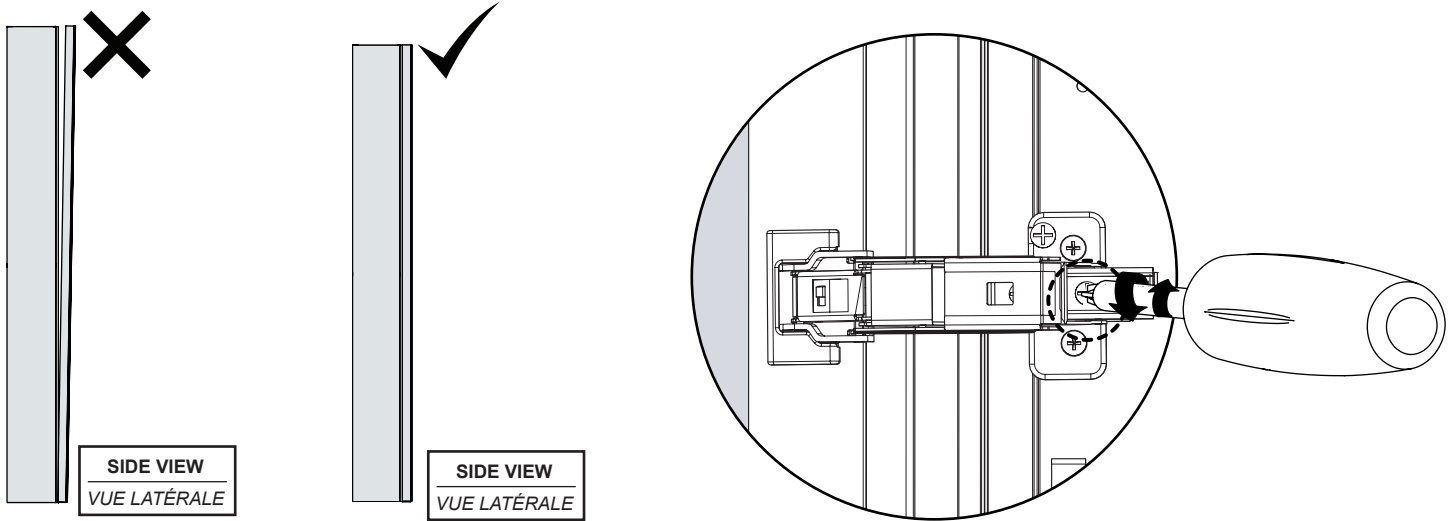

B ALIGN THE DOOR WITH FRAME / ALIGNER LA PORTE AVEC LE CADRE

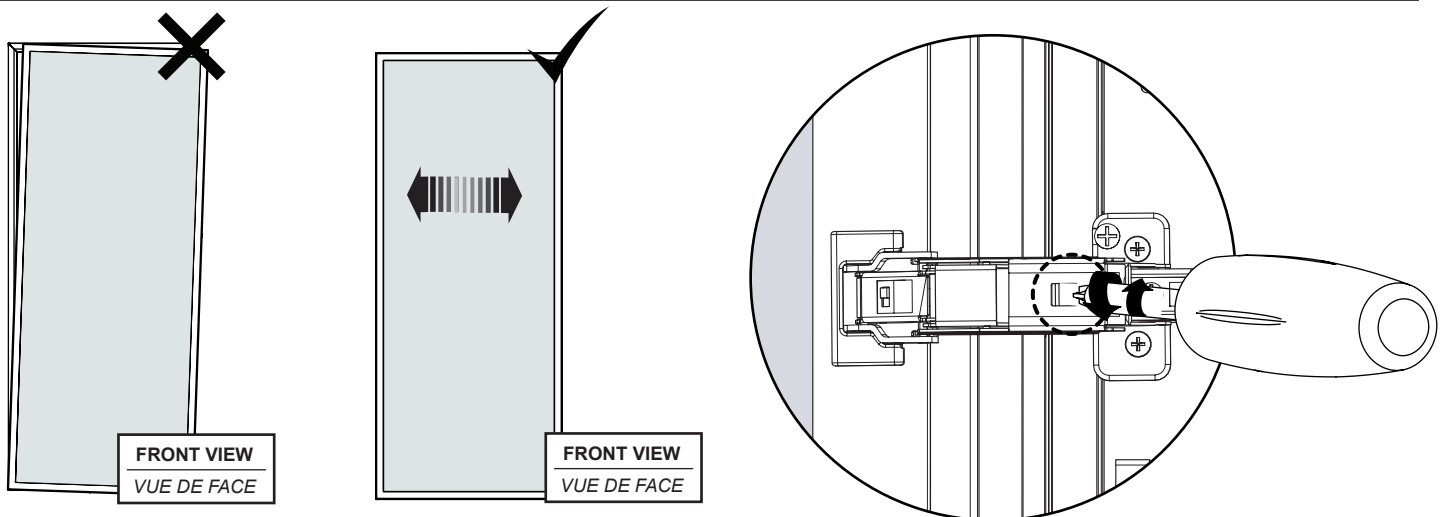

RECESS-MOUNT INSTALLATION / INSTALLATION ENCASTRÉE

IMPORTANT NOTE BEFORE INSTALLATION: WALL PREPARATION À NOTER AVANT L'INSTALLATION : PRÉPARATION DU MUR

THE CABINET MUST BE SUPPORTED BY STUDS ON ALL FOUR SIDES. IF THE WALL HAS NOT YET BEEN FINISHED, MAKE SURE TO HAVE THE EXTRA STUDS INSTALLED BEFORE FINISHING THE WALL. IT IS RECOMMENDED TO HAVE THIS BE DONE BY A PROFESSIONAL. THE FOLLOWING STEPS INDICATE CABINET DIMENSIONS AS WELL AS SUGGESTIONS FOR PROPER PLACEMENT.

LE CABINET DOIT ÊTRE SOUTENU PAR DES OSSATURES MURALE SUR LES QUATRE CÔTÉS. SI LE MUR N'A PAS ENCORE ÉTÉ FINI, ASSUREZ-VOUS D'AVOIR LES OSSATURES SUPPLÉMENTAIRES INSTALLÉS AVANT DE TERMINER LE MUR. IL EST RECOMMANDÉ QUE CELA SOIT FAIT PAR UN PROFESSIONNEL. LES ÉTAPES SUIVANTES INDIQUENT LES DIMENSIONS DU CABINET AINSI QUE DES SUGGESTIONS DE PLACEMENT APPROPRIÉ.

THE CABINET MUST BE SUPPORTED BY STUDS. IT IS RECOMMENDED TO HAVE THIS STAGE CARRIED OUT BY A PROFESSIONAL.

LE CABINET DOIT ÊTRE SOUTENU DANS UNE OSSATURE MURALE. IL EST RECOMMANDÉ DE FAIRE EFFECTUER CETTE ÉTAPE PAR UN PROFESSIONNEL.

IT IS RECOMMENDED TO INSTALL JUNCTION BOX ON THE BOTTOM STUD AND ADD ANOTHER STUD AS A SUPPORT FOR CABINET.

IL EST RECOMMANDÉ D'INSTALLER LE BOÎTIER DE RACCORDEMENT SUR LE MONTANT INFÉRIEUR ET D'AJOUTER UN AUTRE MONTANT COMME SUPPORT POUR LE CABINET.

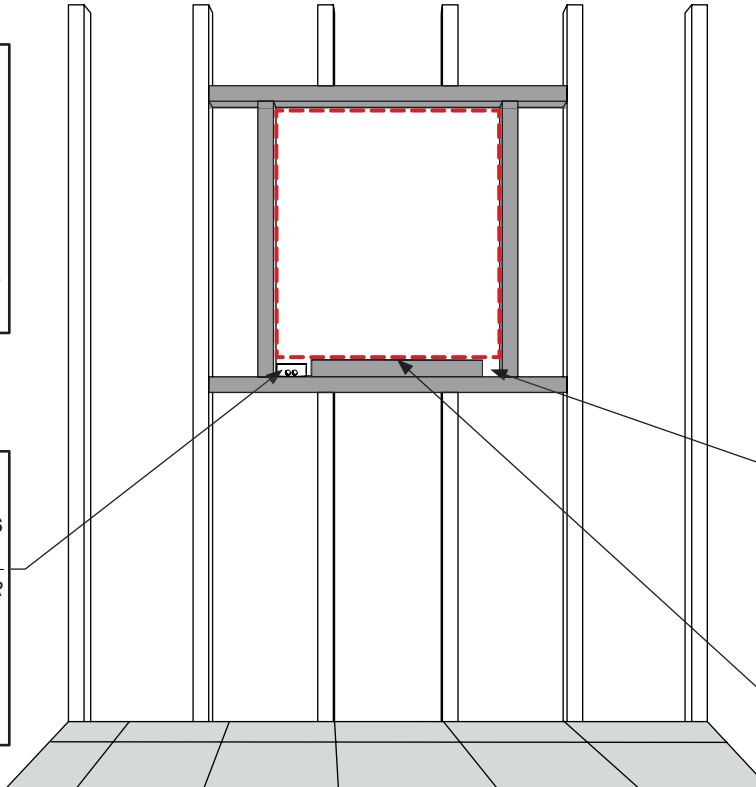

AREA WHERE CABINET WILL BE INSTALLED
ZONE OÙ LE CABINET SERA INSTALLÉ

CABINET SUPPORT BEAMS
SUPPORTS DU CABINET

A GAP OF APPROXIMATELY 1" IS REQUIRED BETWEEN THE BOTTOM AND RIGHT STUDS. THIS WILL PROVIDE CLEARANCE FOR THE BOTTOM OF THE CABINET.

IL FAUT UN ÉCART D'ENVIRON 1" ENTRE LES MONTANTS INFÉRIEUR ET DROIT, CE QUI PERMETTRA DE DÉGAGER LE FOND DU CABINET.

THE TOP OF THIS STUD SHOULD BE A MINIMUM OF 3" ABOVE THE FAUCET.

LE DESSUS DE CE MONTANT DE SUPPORT DOIT ÊTRE AU MOINS 3" AU-DESSUS DU ROBINET.

*REFER TO PAGE 9 FOR ELECTRICAL BOX LOCATION

*CONSULTER LA PAGE 9 POUR L'EMPLACEMENT DU BOÎTIER ÉLECTRIQUE

1 MARK THE CABINET POSITION / MARQUER L'EMPLACEMENT DU CABINET

MARK THE LOCATION OF THE TOP OF THE SUPPORT STUD ON THE DRYWALL. DRAW A LEVELLED LINE 1/4" BELOW THIS MARK. THIS LINE WILL BE THE BOTTOM OF THE HOLE CUTOUT.

MARQUER L'EMPLACEMENT DU DESSUS DU MONTANT DE SUPPORT SUR LE GYPSE. TRACEZ UNE LIGNE NIVELÉE 1/4" EN DESSOUS DE CETTE MARQUE. CETTE LIGNE SERA LE FOND DU TROU DÉCOUPÉ.

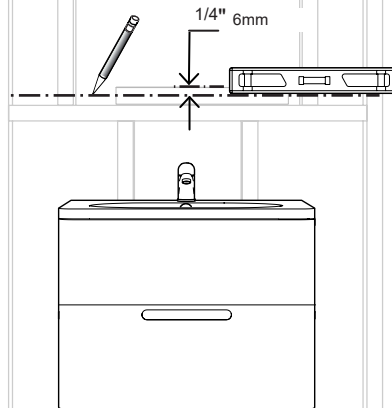

2 MARK AND LEVEL THE DIMENSION FOR RECESSED CABINET / MARQUER ET NIVELER LES DIMENSIONS D'ENCASTREMENT DU CABINET

MARK THE REMAINING 3 LINES OF THE OPENING USING THE DIMENSIONS IN THE TABLE BELOW. THE BOTTOM SUPPORT STUD WILL EXCEED THE BOTTOM OF THE HOLE BY 1/4" TO ENSURE CABINET RESTS ON THE STUD AND NOT DRYWALL

MARQUER LES 3 LIGNES RESTANTES DE L'OUVERTURE EN UTILISANT LES DIMENSIONS DU TABLEAU CI-DESSOUS. LE MONTANT DE SUPPORT INFÉRIEUR DÉPASSE DÉPASSE LE FOND DU TROU DE 1/4" POUR QUE LE CABINET REPOSE SUR LE MONTANT ET NON SUR LE GYPSE.

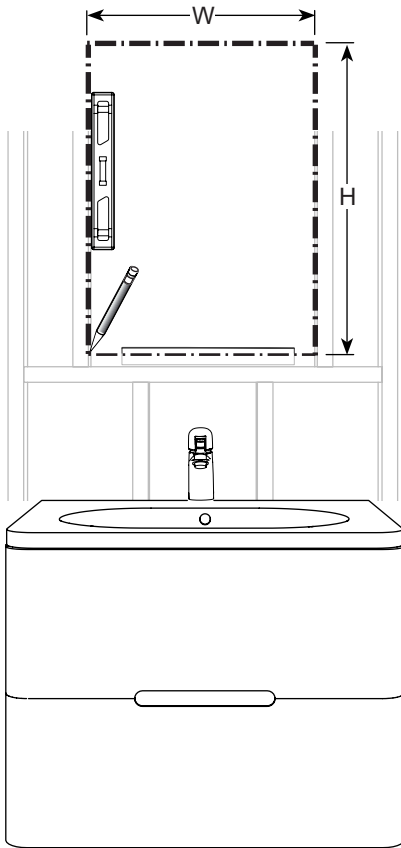

MODEL / MODÈLE	WIDTH / LARGEUR (W)	HEIGHT / HAUTEUR (H)
SINGLE DOOR / PORTE SIMPLE		
MCHS1930	18 3/4"	29 1/2"
MCHS1936	18 3/4"	35 1/2"
MCHS2430	24 1/8"	29 1/2"
MCHS2436	24 1/8"	35 1/2"

BI DOOR / PORTES DOUBLES		
MCHB3030	30 1/8"	29 1/2"
MCHB3036	30 1/8"	35 1/2"

TRI DOOR / PORTES TRIPLES		
MCHT3030	30 1/8"	29 1/2"
MCHT3036	30 1/8"	35 1/2"
MCHT3630	36 1/8"	29 1/2"
MCHT3636	36 1/8"	35 1/2"
MCHT4830	48 1/8"	29 1/2"
MCHT4836	48 1/8"	35 1/2"
MCHT6030	59 3/4"	29 1/2"
MCHT6036	59 3/4"	35 1/2"

3 CUT THE OPENING IN THE DRYWALL / COUPER L'OUVERTURE DANS LE GYPSE

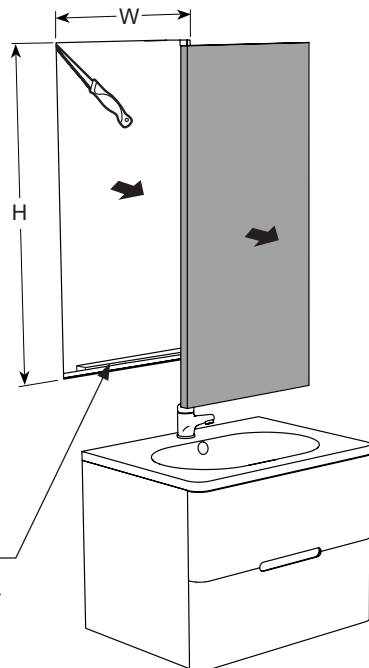

THE CABINET SHOULD REST ON THE BOTTOM SUPPORT STUD AND NOT THE DRYWALL.

LE CABINET DOIT REPOSER SUR LE MONTANT DE SUPPORT INFÉRIEUR ET NON SUR LE GYPSE.

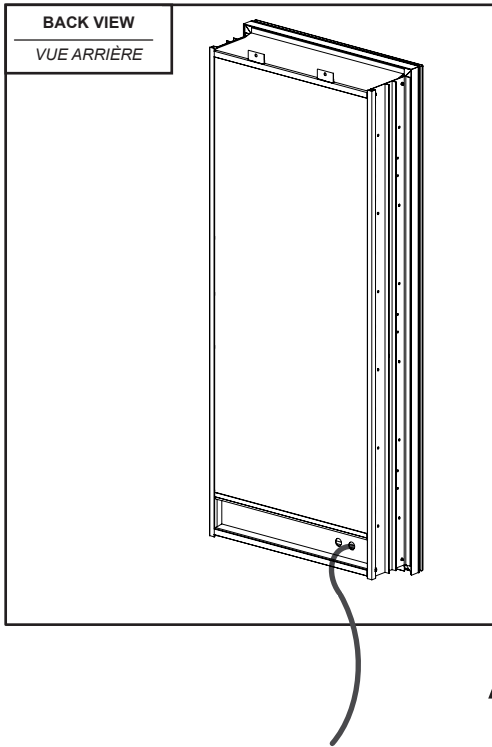

**AVERTISSEMENT
WARNING**

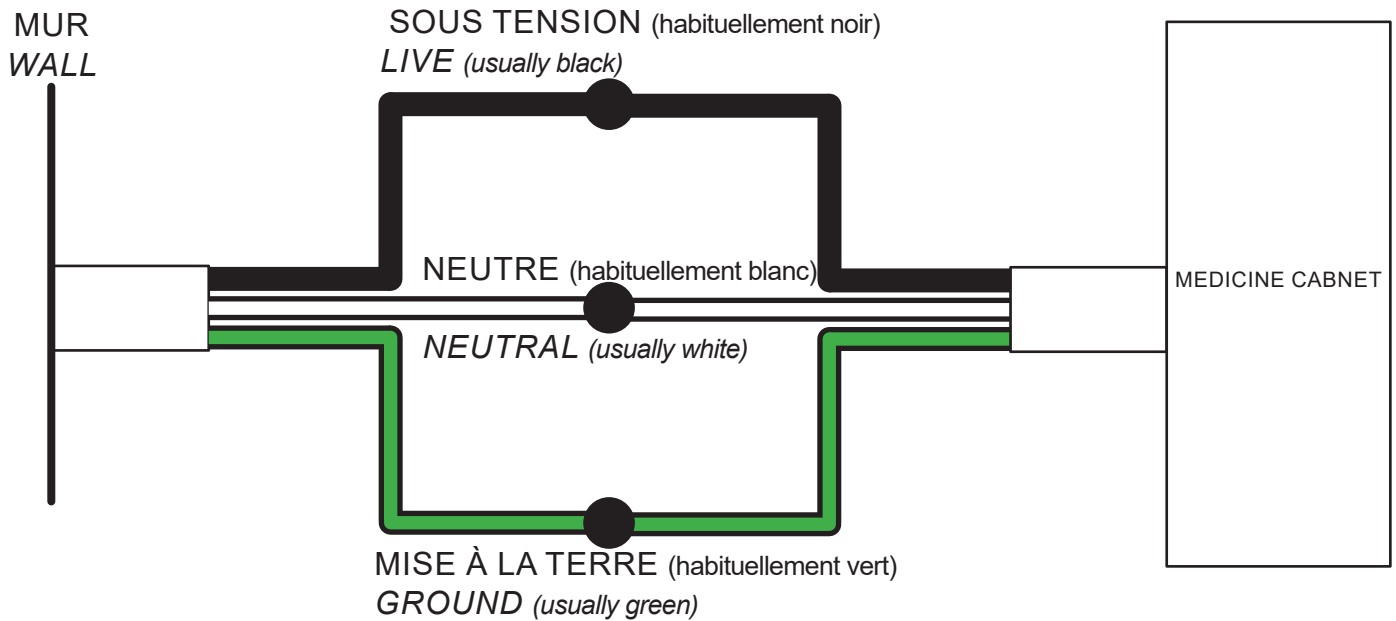

VEUILLEZ NOTER: Les couleurs présentées dans le diagramme ci-dessus sont basées sur un système standardisé. Elles peuvent varier selon votre système électrique. Pour tout doute sur la connexion, veuillez vous référer à un électricien professionnel qualifié. Fleurco n'est pas responsable des conséquences d'un mauvais raccordement électrique pouvant mener à des chocs électriques, au feu et à la mort.

PLEASE NOTE: The colors referenced in the diagram above is based on conventional standards and may differ between households. If there is any confusion as to how these should be connected, please seek the help of a licensed professional electrician. Electric shock, fire hazard and death are possible consequences of poor wiring for none of which Fleurco will be held liable.

RIGHT SIDE INSTALLATION / INSTALLATION DU CÔTÉ DROIT

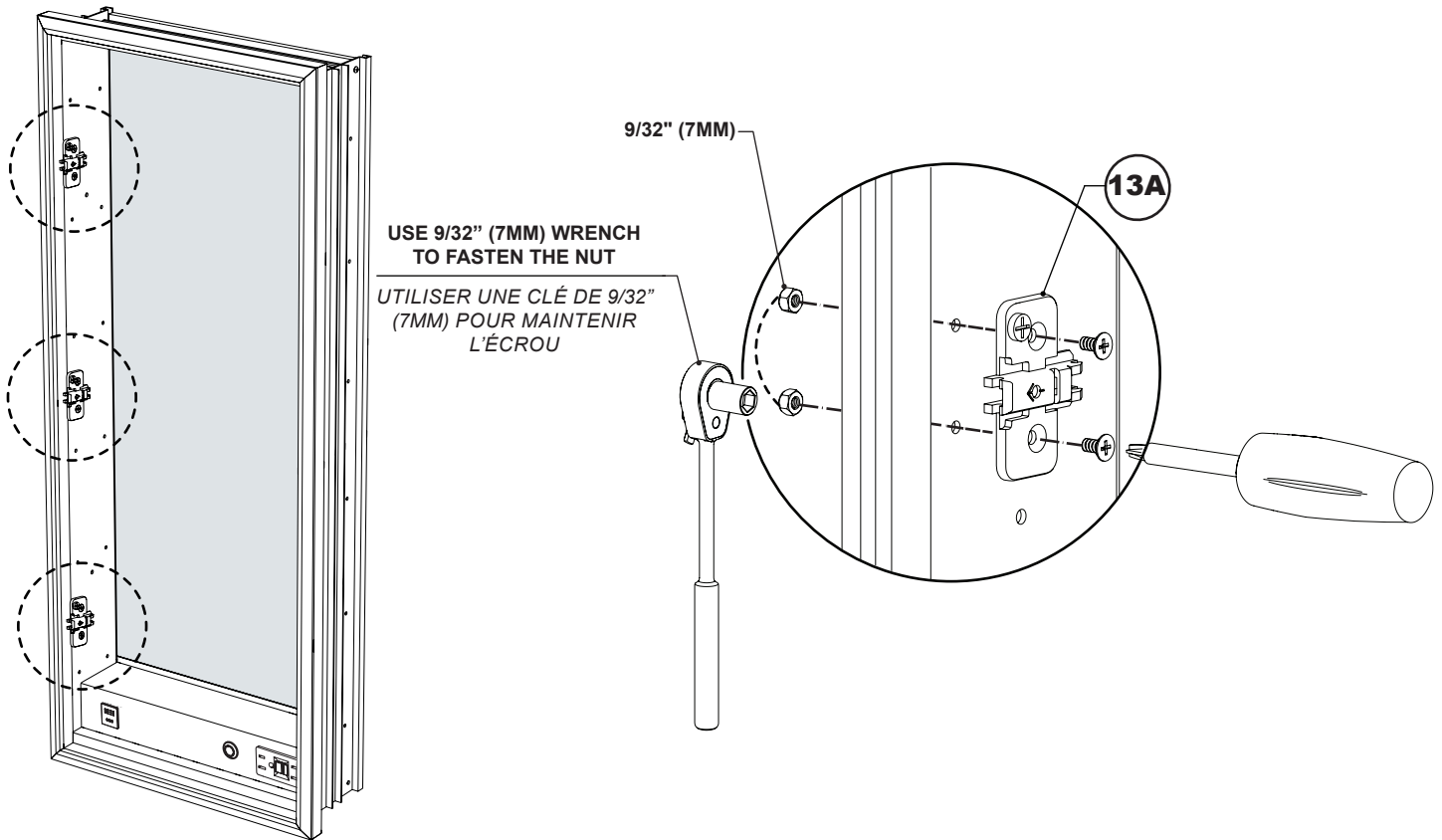

LEFT SIDE INSTALLATION / INSTALLATION DU CÔTÉ GAUCHE

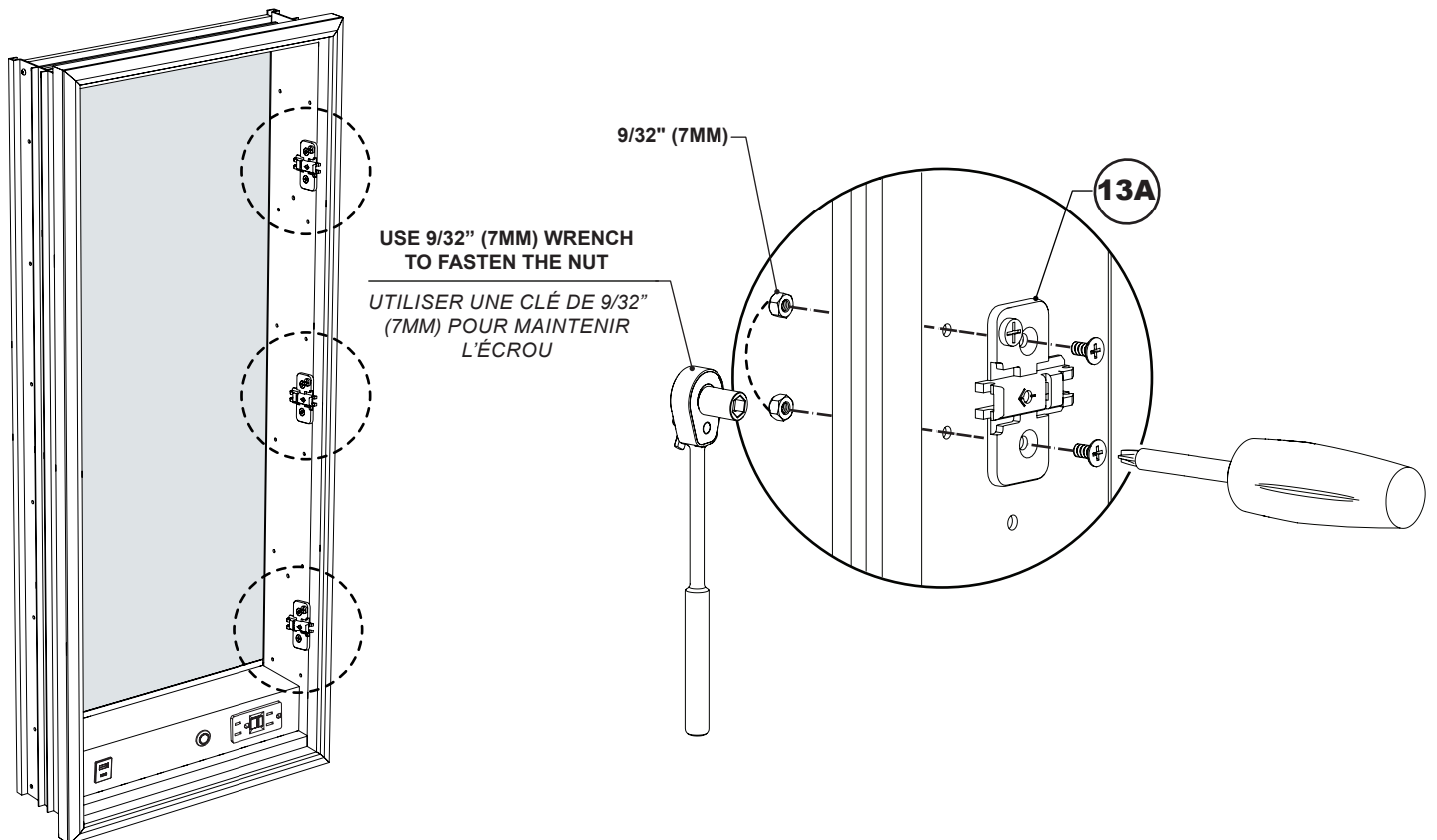

7 INSERT THE CABINET INTO THE WALL / *INSÉRER LE CABINET DANS LE MUR*

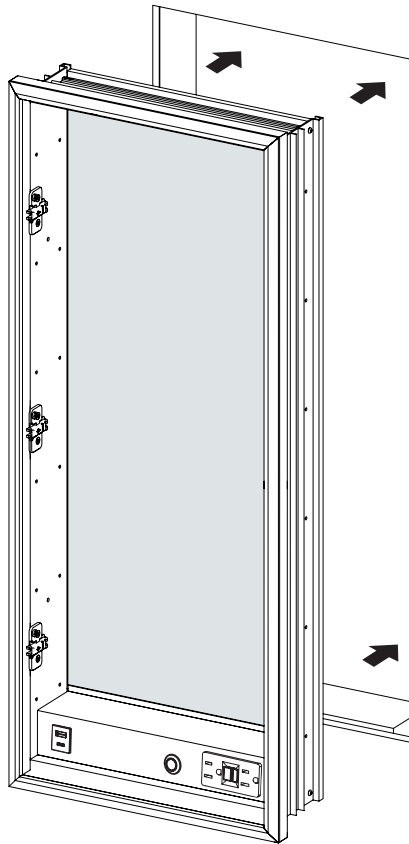

8 SECURE THE MEDICINE CABINET INTO THE WALL / *SÉCURISER LE CABINET DANS LE MUR*

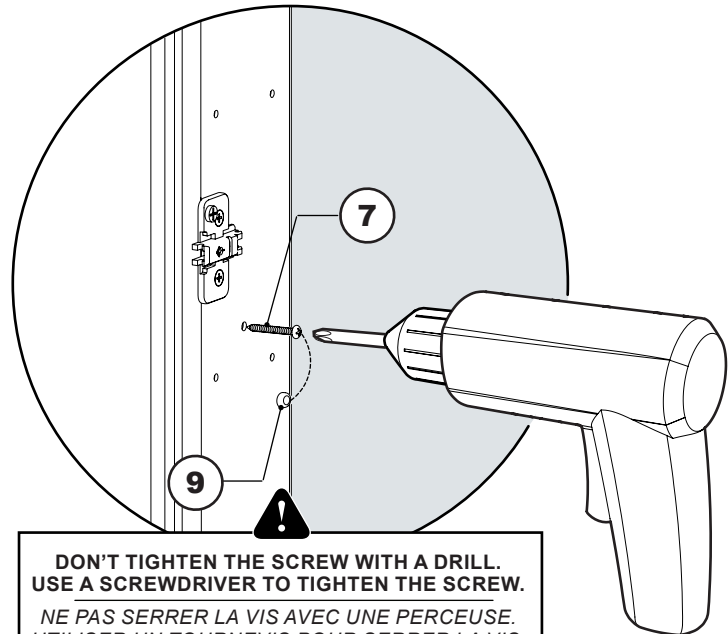
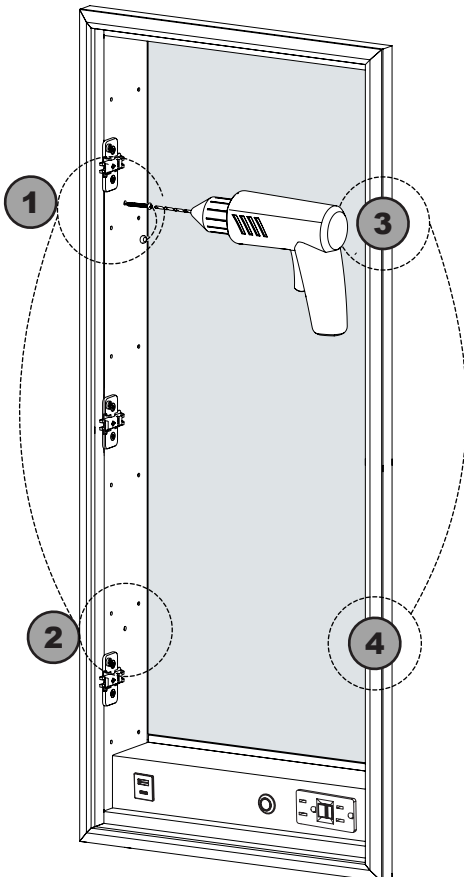

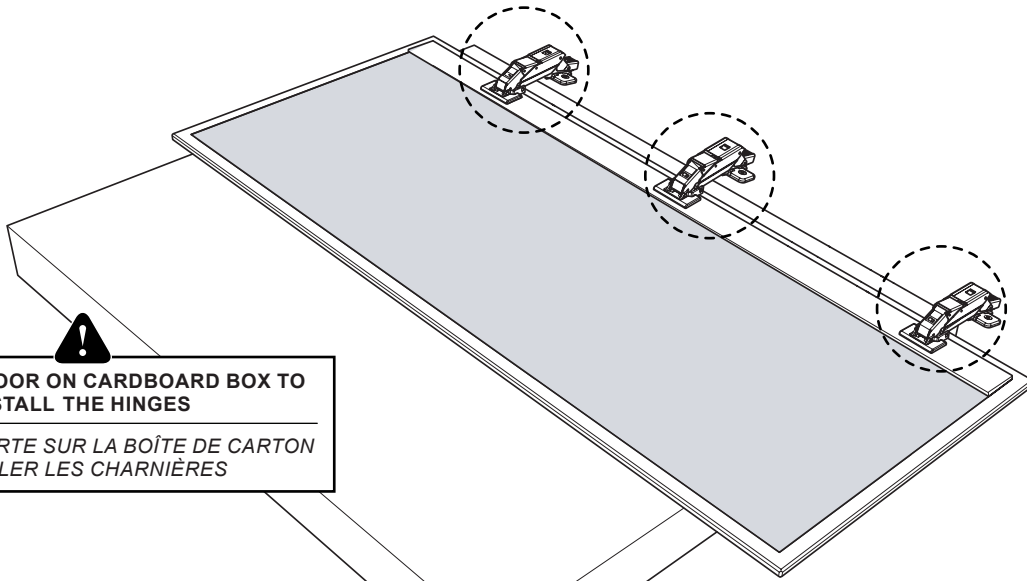

**PLACE THE DOOR ON CARDBOARD BOX TO
INSTALL THE HINGES**

*PLACER LA PORTE SUR LA BOÎTE DE CARTON
POUR INSTALLER LES CHARNIÈRES*

A

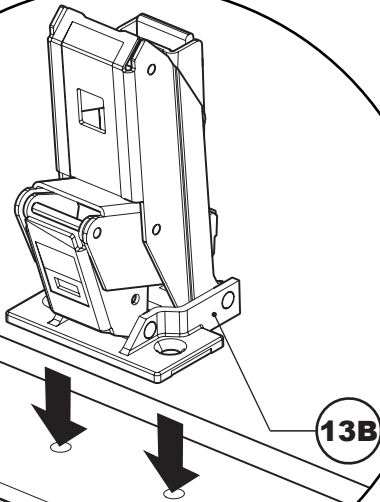

OPEN THE HINGES AS INDICATED .

OUVRIER LES CHARNIÈRES COMME INDIQUÉ.

D

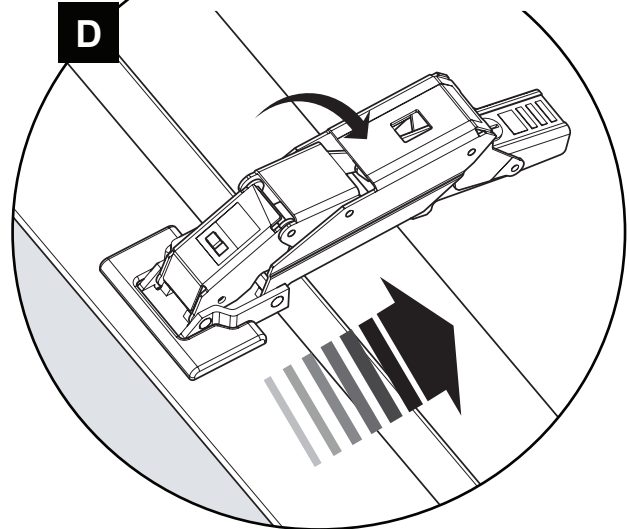

B

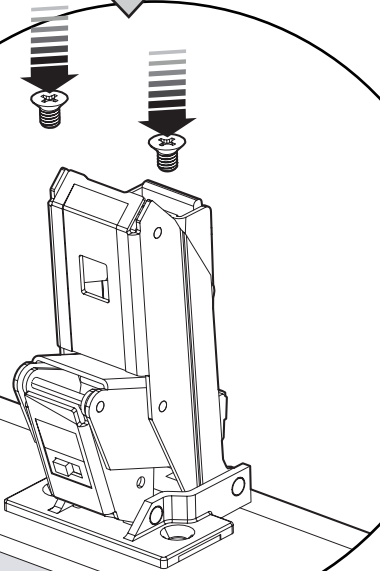

**INSTALL THE CAP
INSTALLER LA COUVERCLE**

C

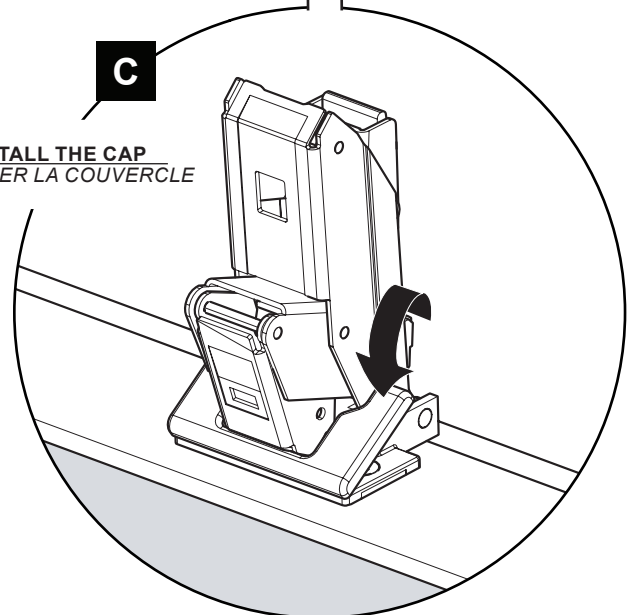

10 INSTALL THE PANEL / INSTALLER LA PORTE

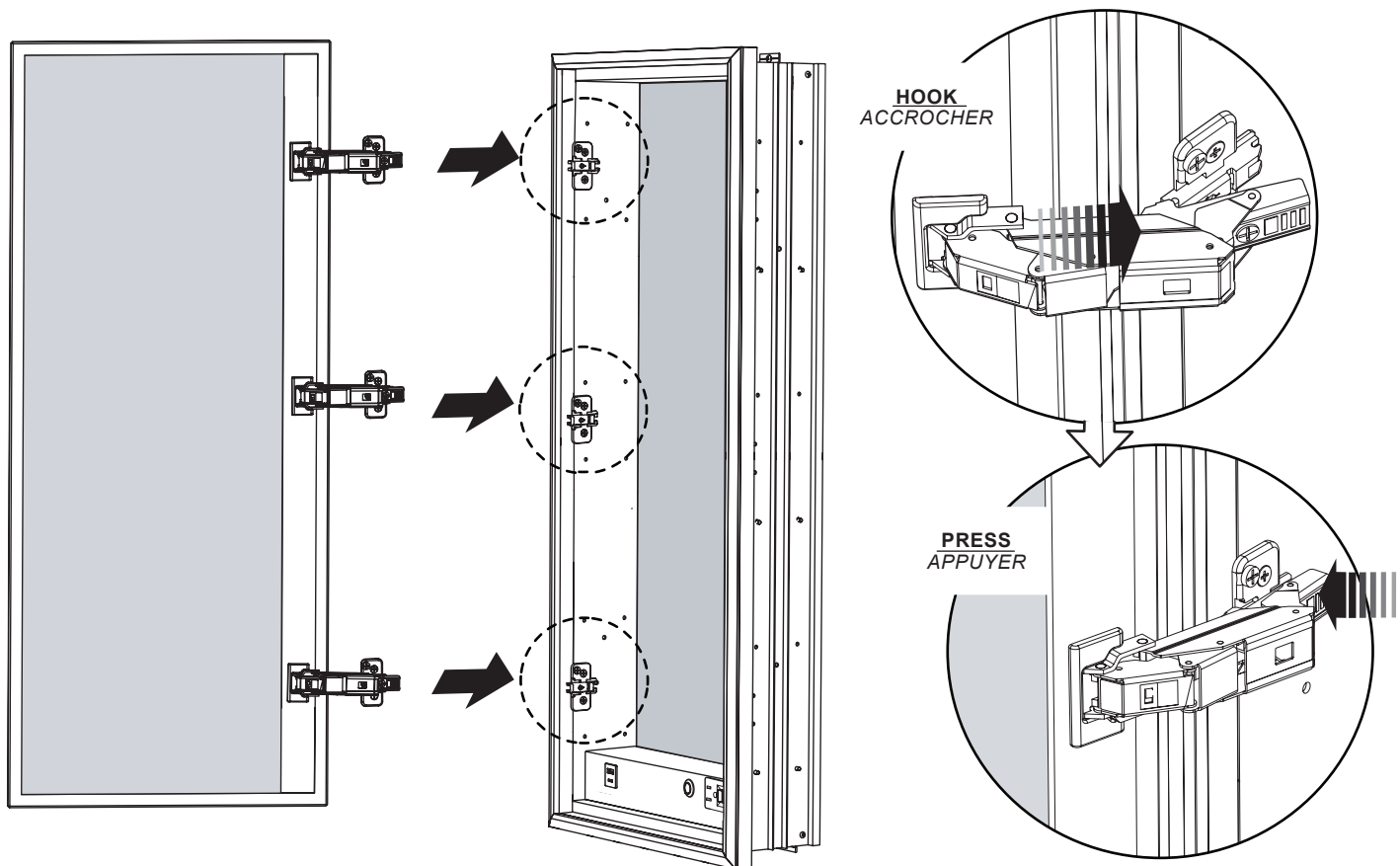

11 INSTALL THE SHELF SUPPORT PEGS / INSTALLER LES SUPPORTS DE TABLETTE

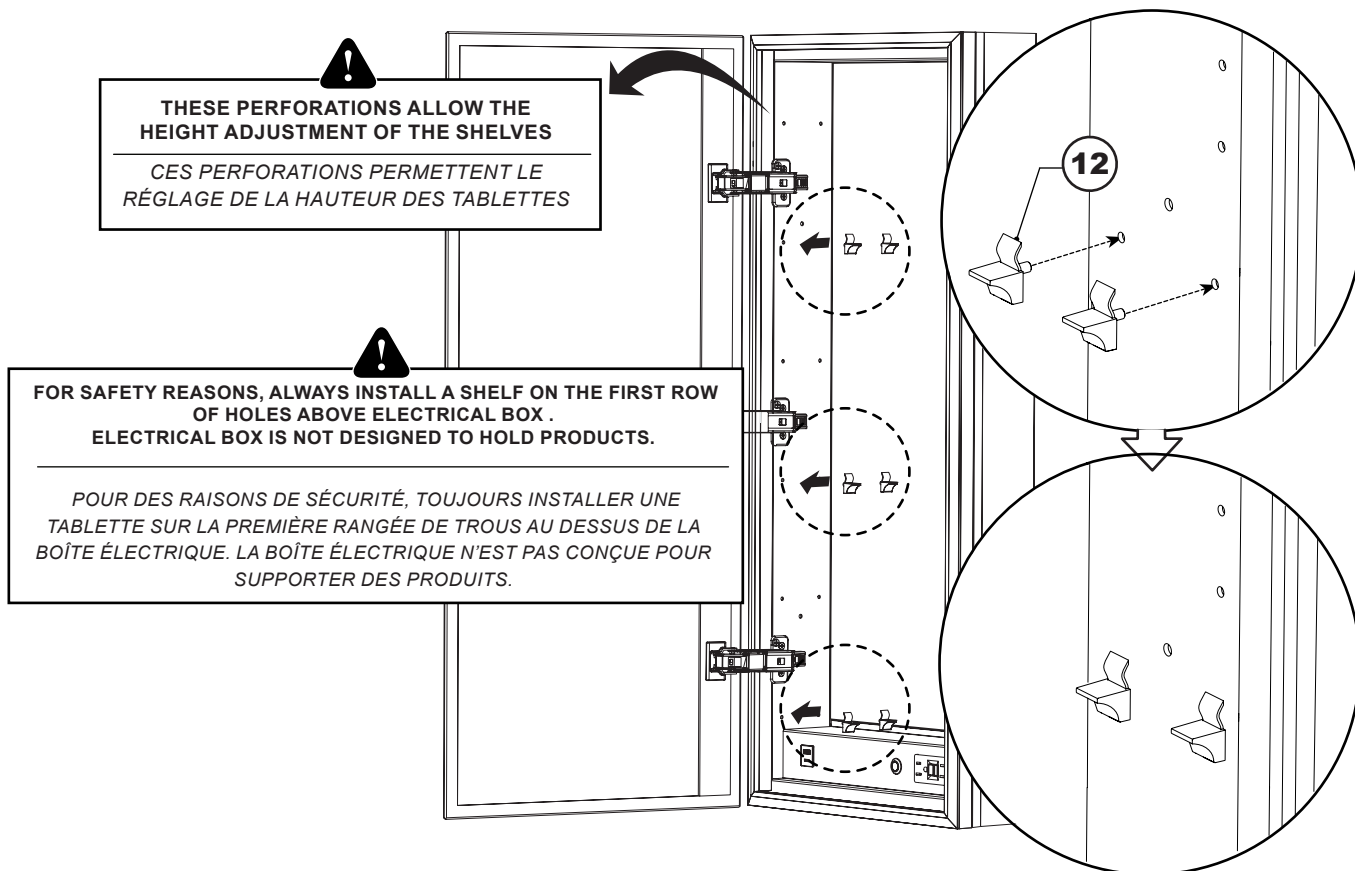

12 INSTALL THE GLASS SHELVES / INSTALLER LES TABLETTES EN VERRE

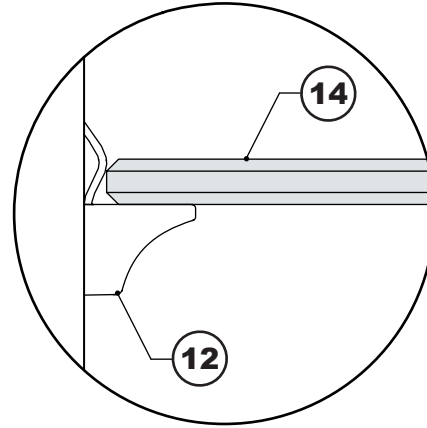
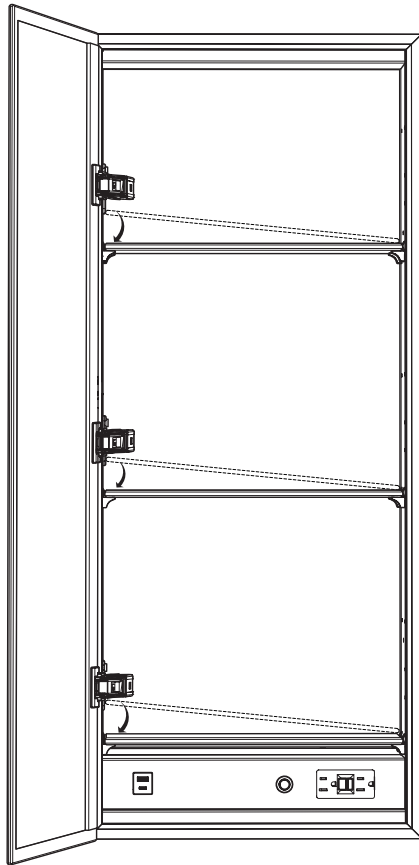

13 INSTALL HOLE CAPS AND SCREW CAPS / INSTALLER LES CACHE-TROUS ET LES COUVRE-VIS

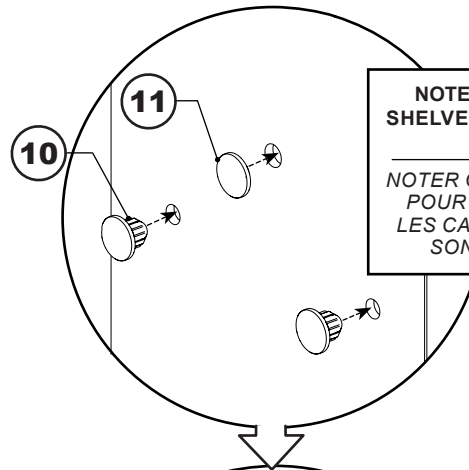
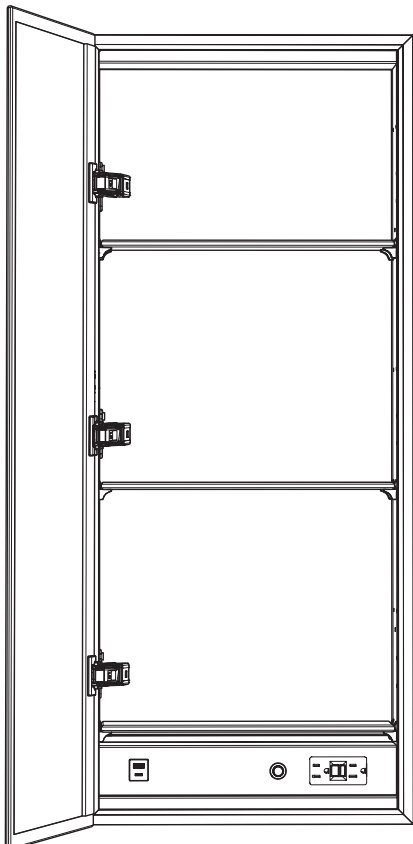

!
NOTE THAT HOLE CAPS #10 ARE FOR SHELVES HOLES AND ADHESIVE CAPS #11 ARE FOR OTHER HOLES.
NOTER QUE LES CACHE-TROUS #10 SONT POUR LES TROUS DES TABLETTES ET LES CACHE-TROUS AUTOCOLLANTS #11 SONT POUR LES AUTRES TROUS.

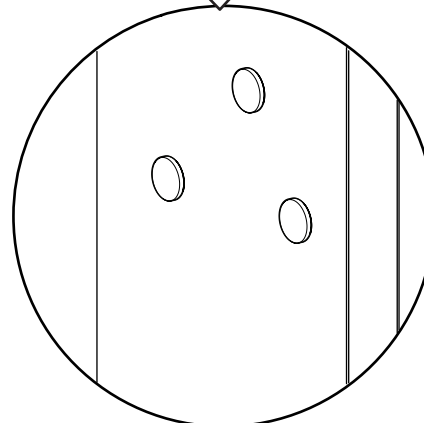

14 ADJUST THE DOOR / AJUSTER LA PORTE

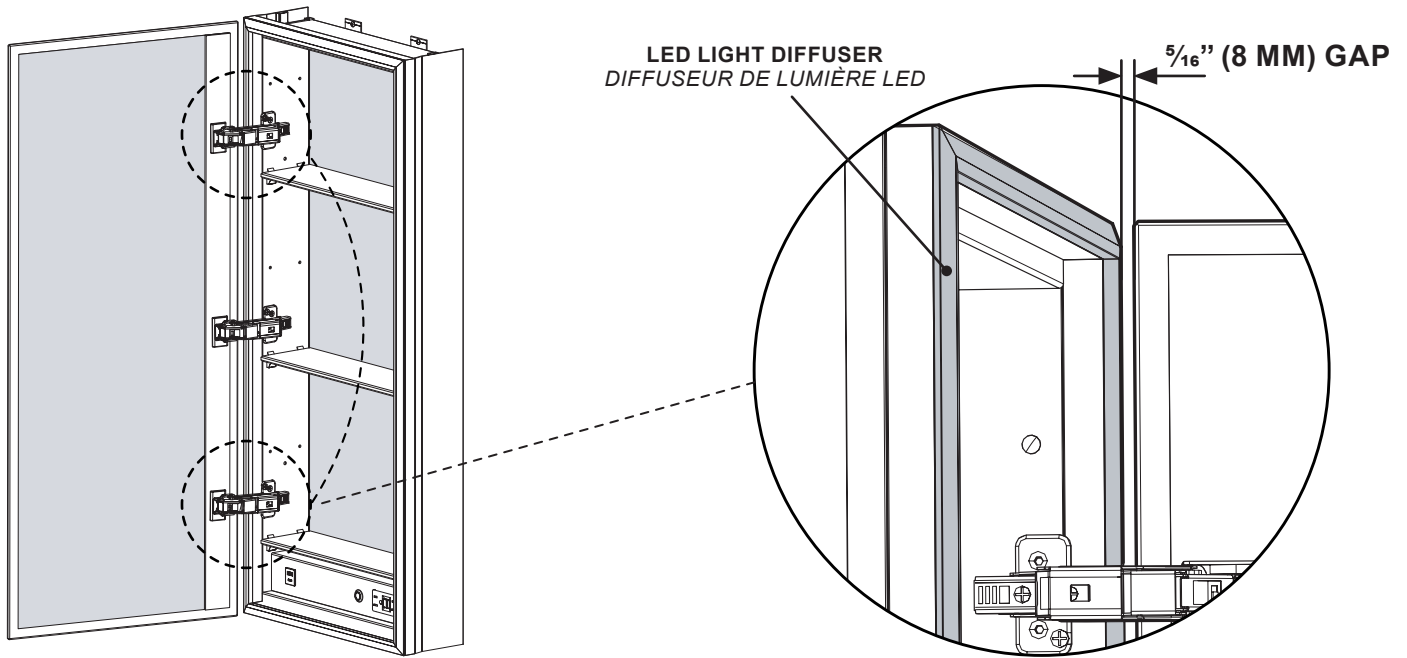

A ADJUST THE GAP BETWEEN DOOR AND CABINET / AJUSTER L'ESPACE ENTRE LA PORTE ET LE CABINET

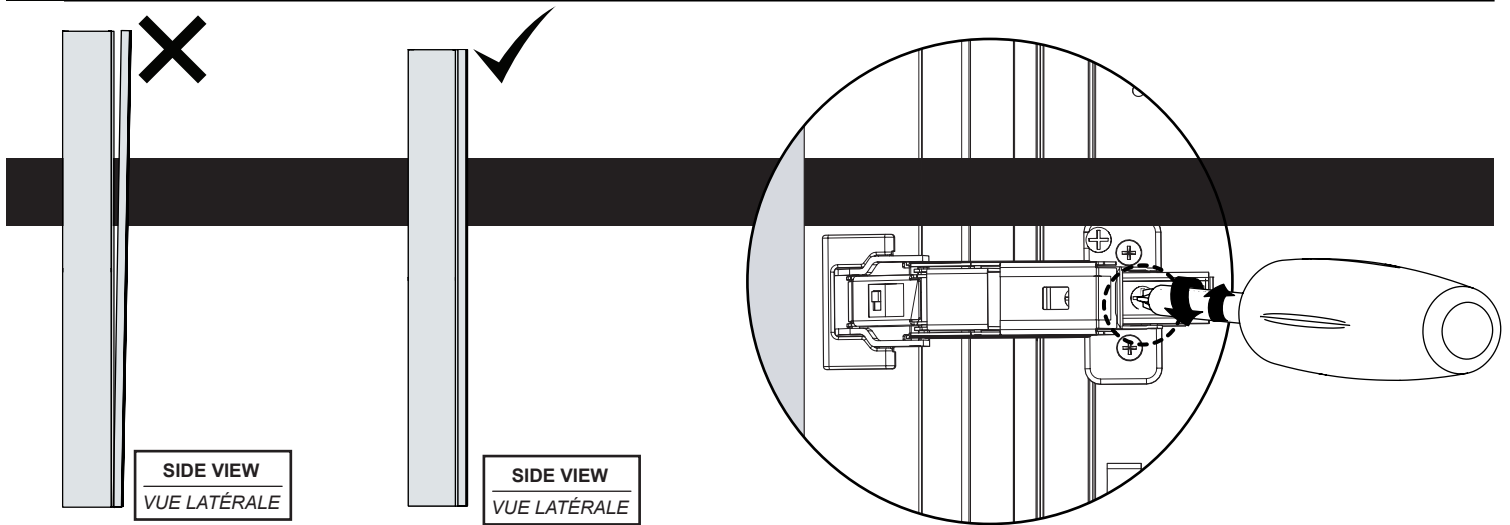

B ALIGN THE DOOR WITH FRAME / ALIGNER LA PORTE AVEC LE CADRE

