



Model shown / Modèle présenté : Madrigal (BZMA6731-18)

FEATURES / CARACTÉRISTIQUES :

- ◆ Sturdy construction with fibreglass reinforcement
Construction de fibre de verre solide renforcée
- ◆ Easy to clean white high-gloss surface
Surface blanche très brillante et facile d'entretien
- ◆ Spacious freestanding bathtub for better comfort
Baignoire spacieuse autoportante pour un confort accru
- ◆ cUPC classified certification
Certification cUPC
- ◆ 10-year limited warranty
Garantie limitée de 10 ans
- ◆ Easy to install
Facile à installer
- ◆ Pre-installed drain and overflow
Trop-plein et drain préinstallés pour une installation rapide
- ◆ Ø 1½" Tailpiece included
Tube de vidange de Ø 1½" inclus
- ◆ Compatible with Fleurco RapidConnect® drain for freestanding tubs
Compatible avec le drain de plancher Fleurco RapidConnect® pour baignoires autoportantes

 **Find a store near you**
Trouvez votre magasin le plus proche

Technical information / Information technique

Project / Projet : Contact : Date : Tel / Tél :	Products and specifications are subject to change without notice. Please contact our sale office for any further enquiry. <i>Les produits et les caractéristiques peuvent être modifiés sans préavis. Pour toute demande de renseignements, veuillez communiquer avec notre service à la clientèle.</i>	Hardware Finish Fini de la quincaillerie
		11: Chrome 25: Brushed Nickel / Nickel brossé

Model Modèle	Net Weight Poids net		Capacity Capacité	
	LB	KG	US GAL	L
BZMA5931	99	45	55	210
BZMA6731	104	50	67	255

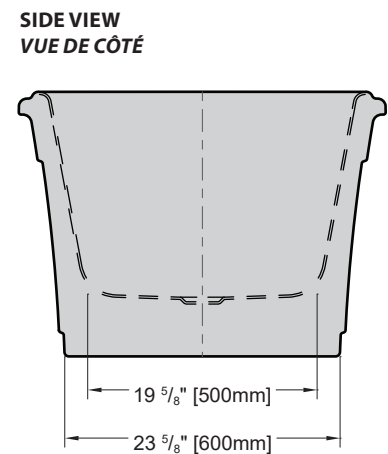
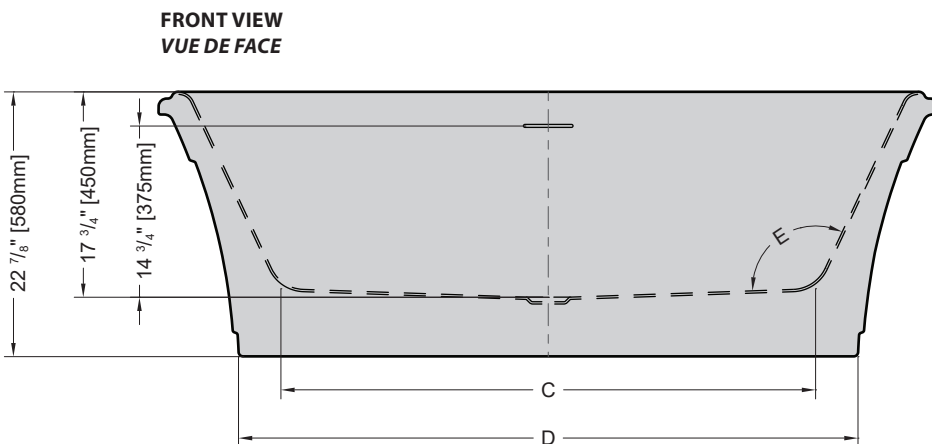
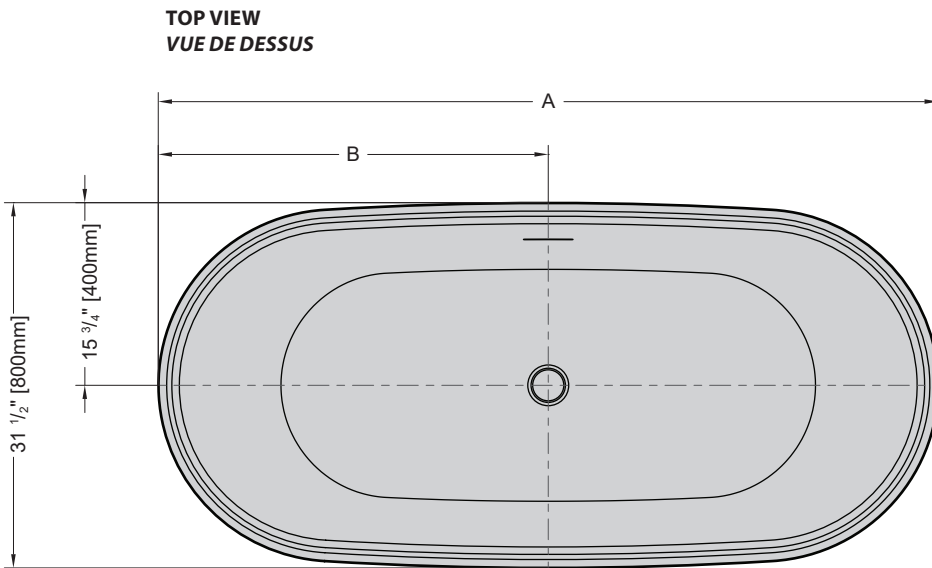

Tolerance on dimensions: ± 1/4" [6 mm]
 Tolerance des dimensions: ± 1/4" [6 mm]

Model Modèle	A	B	C	D	E
BZMA5931	59" 1500mm	29 1/2" 750mm	40 1/8" 1020mm	45 1/4" 1150mm	113°
BZMA6731	66 7/8" 1700mm	33 1/2" 850mm	45 7/8" 1165mm	53 1/8" 1350mm	117°