



Model shown / Modèle présenté : Aura (VA21105-18-11)

FEATURES / CARACTÉRISTIQUES :

- ◆ Spacious double basket for your shower wall
Double panier spacieux pour votre douche
- ◆ Slotted bottom for proper drainage
Fentes dans le fond pour un drainage adéquat
- ◆ Removable white tray for easy cleaning
Plateau blanc amovible pour faciliter le nettoyage
- ◆ Can be installed at any height
Peut être installé à la hauteur de votre choix
- ◆ Materials: Stainless steel & ABS
Matériaux: Acier inoxydable & ABS
- ◆ 5-year limited warranty
Garantie limitée de 5 ans
- ◆ Easy to install (see Instruction Manual)
Facile à installer (Voir le manuel d'instruction)
- ◆ Hardware included
Quincaillerie incluse

 Find a store near you
Trouvez votre magasin le plus proche

Technical information / Information technique

<p>Project / Projet : Contact : Date : Tel / Tél :</p>	<p>Products and specifications are subject to change without notice. Please contact our sale office for any further enquiry. <i>Les produits et les caractéristiques peuvent être modifiés sans préavis. Pour toute demande de renseignements, veuillez communiquer avec notre service à la clientèle.</i></p>	<p>Hardware Finish Fini de la quincaillerie</p> <p>11: Chrome 18: White / Blanc</p>
---------------------------------------------------------------------------------------------------	---------------------------------------------------------------------------------------------------------------------------------------------------------------------------------------------------------------------------------------------------------------------------------------------------------------------	---------------------------------------------------------------------------------------------------------------------------

TOP VIEW
VUE DE DESSUS

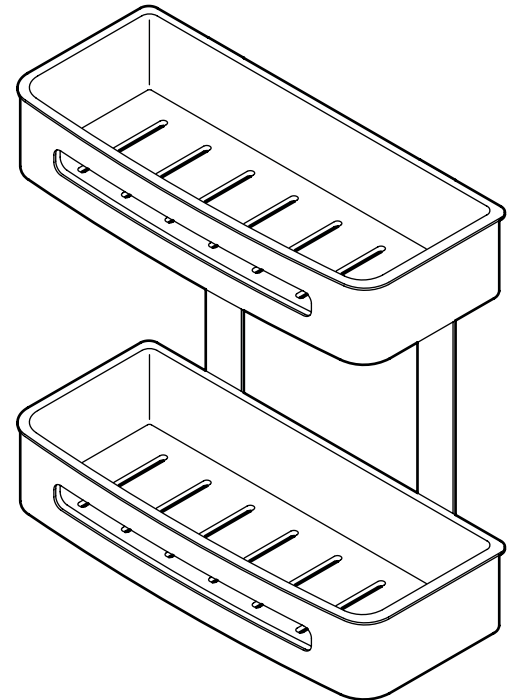
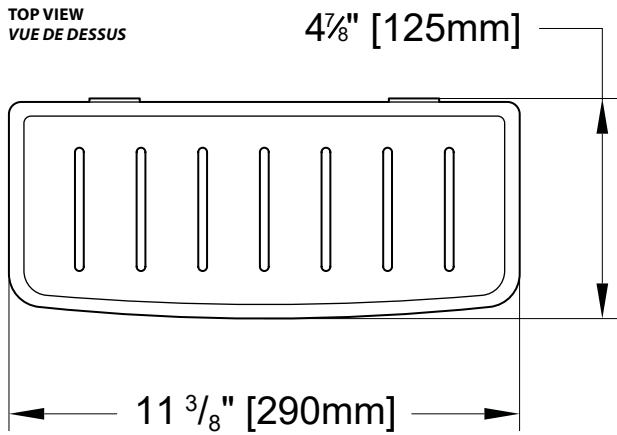

FRONT VIEW
VUE DE FACE

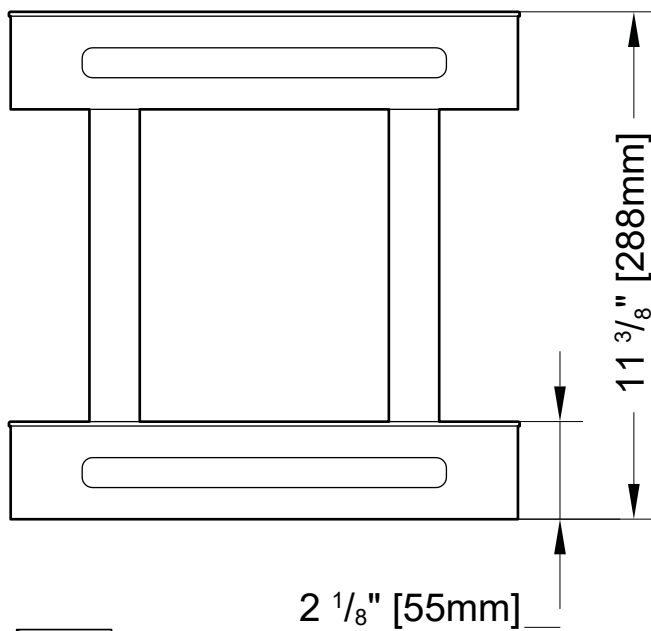

SIDE VIEW
VUE DE CÔTÉ

