

# INSTRUCTION MANUAL - GUIDE D'INSTALLATION

## K202

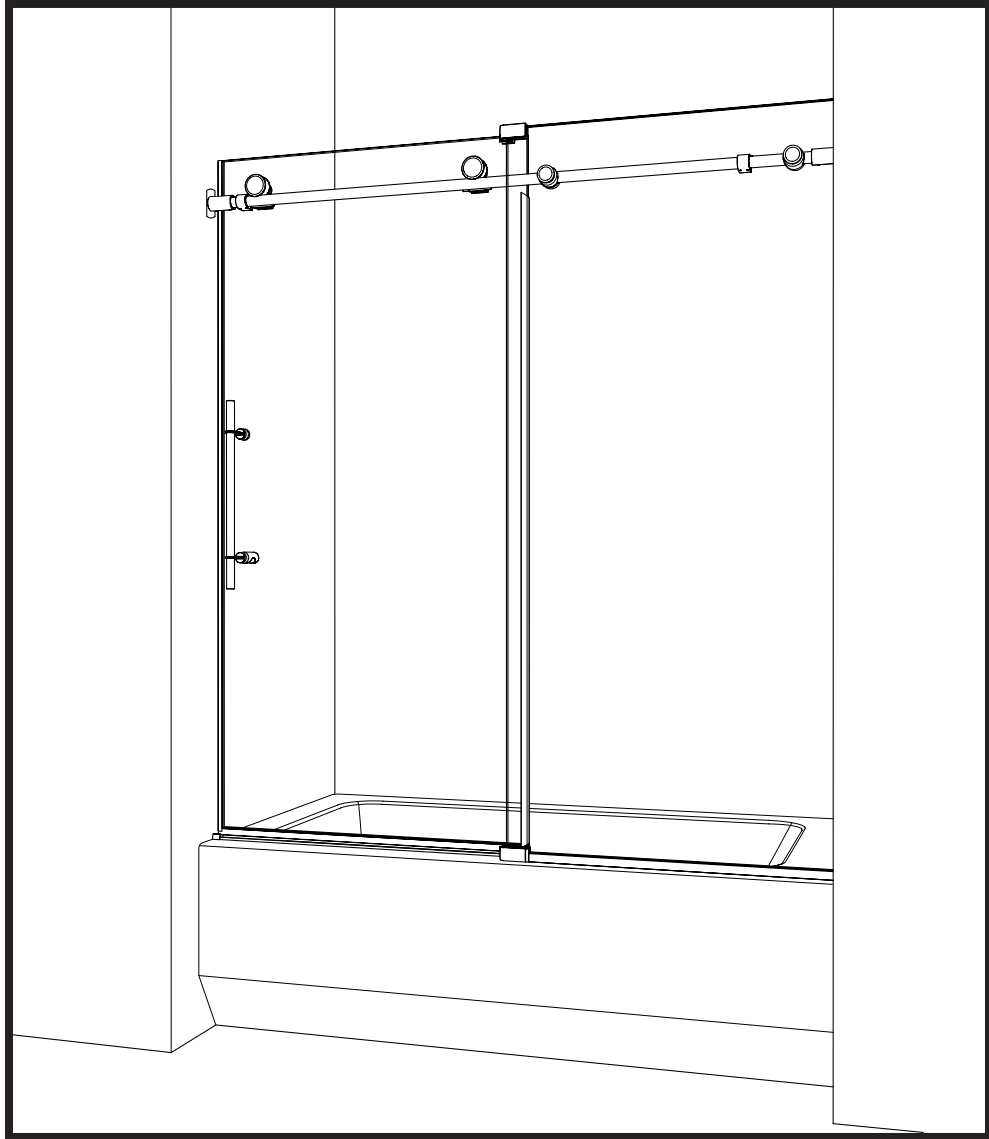

06 / 2014



**2 PEOPLE REQUIRED**  
**2 PERSONNES REQUIS**



**It is mandatory to have a wall stud on each side of the shower unit to securely fasten the rail to the walls.**

*Il est indispensable d'avoir une ossature murale sur chaque côté de la douche pour fixer la barre de roulement.*

Please keep this manual and product code number for future reference and for ordering replacement parts if necessary.

*Veillez conserver ce manuel et le code de produit pour des références futures, et au besoin, la commande de pièces de rechange.*

#### GENERAL INSTRUCTIONS

- Read this manual carefully and completely before proceeding.
- It is recommended that you wear safety glasses at all times during the installation.



#### INSTRUCTIONS GÉNÉRALES

- Lire attentivement et complètement le manuel d'installation avant de procéder.
- Il est recommandé de porter des lunettes de sécurité en tout temps lors de l'installation.



#### INSTALLATION OVER CERAMIC TILES

- If your shower door is to be installed over ceramic tiles, the tiles should lay completely under the wall jamb.
- Silicone should be used to seal the gap where the ceramic tiles meet the fixed panel.

#### INSTALLATION SUR LES TUILES EN CÉRAMIQUE

- Si votre porte de douche doit être installée sur une bordure en céramique, le jambage doit reposer complètement sur cette dernière.
- Le calfeutrage doit être appliqué sur le côté extérieur de la douche où le panneau fixe rencontre la bordure en céramique.

#### NOTICE

- Caulking: no sealant is required inside the shower, unless otherwise stated.
- Some models are equipped with clear sealing gaskets.

#### NOTE

- Calfeutrage: aucun scellant n'est nécessaire à l'intérieur de la douche.
- Certains modèles sont dotés de joints d'étanchéité clairs.

#### CARE FOR YOUR SHOWER DOOR

- Never use scouring powder pads or sharp instruments on metal pieces or glass panels. An occasional wiping down with a mild soap diluted in water is all that is needed to keep the panels and aluminum parts looking new.
- We recommend wiping the glass panels with a squeegee after each use.

#### L'ENTRETIEN DE VOTRE DOUCHE

- Ne jamais utiliser de poudre ou de tampon à récurer, ni d'instrument tranchant sur les parties en métal ou en verre. De temps à autre, il suffit de nettoyer la porte avec une solution d'eau et un détergent doux pour conserver l'aspect neuf des panneaux de verre et du cadre en aluminium.
- Nous recommandons de passer une raclette de douche sur les panneaux de verre après chaque utilisation.

## TOOLS REQUIRED / OUTILS REQUIS

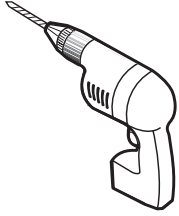

**DRILL**  
PERCEUSE

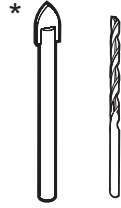

**1/4" & 1/8" DRILL BITS**  
MÈCHES 1/4" & 1/8"



**SCREWDRIVER**  
TOURNEVIS



**SCREWDRIVER**  
TOURNEVIS



**PENCIL**  
CRAYON



**SUPER GLUE**  
COLLE FORTE



**BLOCK**  
BLOC

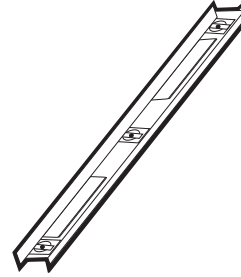

**LEVEL**  
NIVEAU

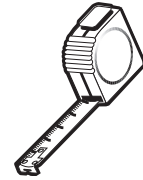

**TAPE MEASURE**  
RUBAN À MESURER

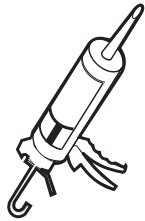

**SILICONE**  
SCÉLLANT

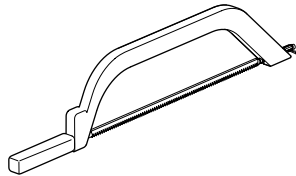

**HACKSAW**  
SCIE À MÉTAUX

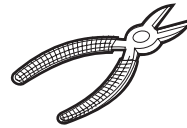

**CUTTING PLIERS**  
PINCE COUPANTE



**MALLET**  
MAILLET

\* Use a 1/4" drill bit when drilling into ceramic tiles

\* Utiliser une mèche de 1/4" pour percer des tuiles en céramique.

## TOOLS REQUIRED TO CUT THE RUNNING RAIL OUTILS REQUIS POUR COUPER LA BARRE DE ROULEMENT

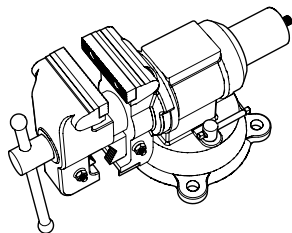

**TABLE VISE**  
ÉTAU DE TABLE

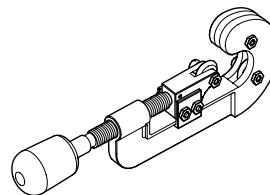

**TUBE CUTTER WITH CUTTER WHEEL FOR STAINLESS  
STEEL (TUBE DIAMETER : 1" / 25.4mm)**  
COUPE-TUBE AVEC UNE ROUE COUPANTE POUR ACIER  
INOXYDABLE (DIAMÈTRE DU TUBE: 1" / 25.4mm)

# PARTS LISTING / LISTE DES PIÈCES

## POSSIBLE CONFIGURATIONS / CONFIGURATIONS POSSIBLES

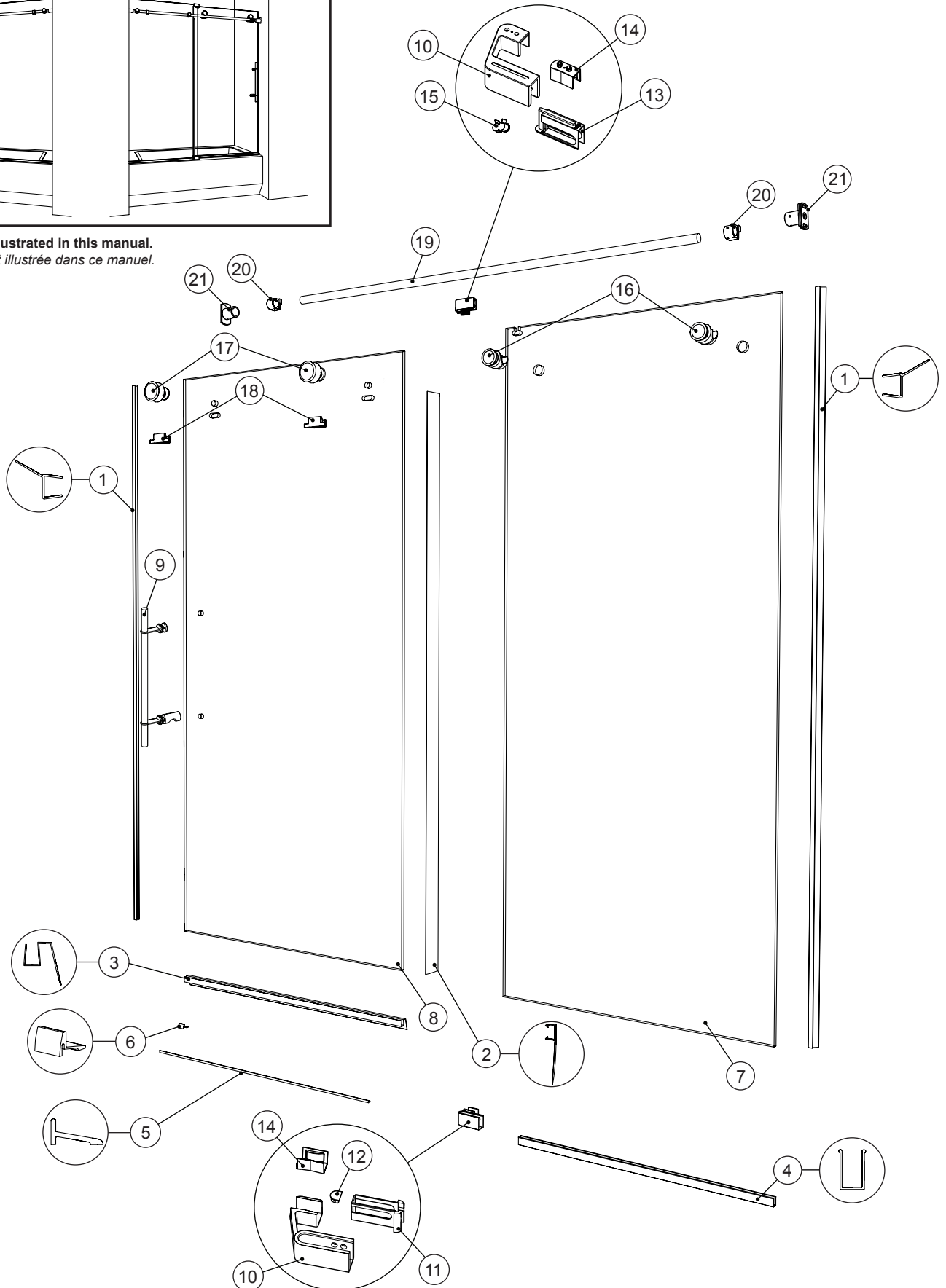
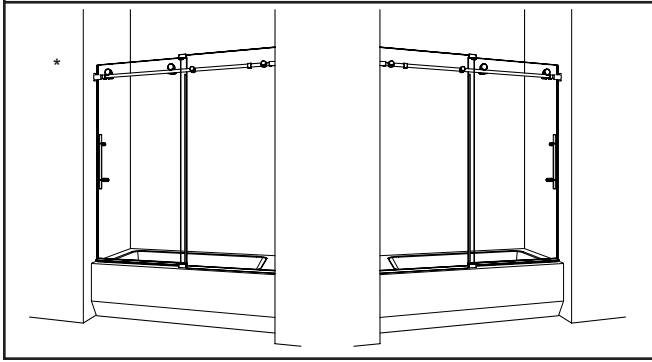

**PARTS LISTING / LISTE DES PIÈCES**

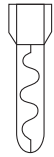

22



23

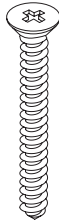

24

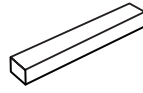

25

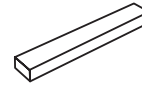

26

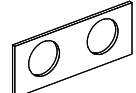

27

ITEM	PARTS AND HARDWARE / PIÈCES ET QUINCAILLERIE	QTY
1	SIDE GASKET / JOINT DE CÔTÉ	2
2	MID GASKET / JOINT LATÉRAL	1
3	BOTTOM DOOR GASKET / JOINT INFÉRIEUR DE LA PORTE	1
4	U-CHANNEL / PROFILÉ EN "U"	1
5	THRESHOLD / SEUIL	1
6	THRESHOLD ANCHOR / ANCRAGE DU SEUIL	1
7	FIXED PANEL / PANNEAU FIXE	1
8	DOOR PANEL / PANNEAU DE PORTE	1
9	HANDLE ( see chart above ) / POIGNÉE ( voir le tableau ci-dessus )	1
10	GUIDE / GUIDE	2
11	BOTTOM SLEEVE / GAINÉ PROTECTRICE INFÉRIEURE	1
12	GUIDE CAP / CAPUCHON DU GUIDE	1
13	TOP SLEEVE / GAINÉ PROTECTRICE SUPÉRIEURE	1
14	PLASTIC GUIDE / GUIDE EN PLASTIQUE	2
15	SCREW INSERT / INSERT DE VIS	1
16	GLASS FASTENER / FIXATION DE VERRE	2
17	ROLLER / ROULETTE	2
18	ANTI-JUMP / ANTI-SAUT	2
19	RUNNING RAIL / BARRE DE ROULEMENT	1
20	STOPPER / BUTOIR	2
21	WALL BRACKET / SUPPORT MURAL	2
22	WALL PLUG / CHEVILLE	4
23	FLAT SELF-DRILLING SCREW #6 (1") / VIS PLAT AUTO-PERÇANTE # 6 (1")	1
24	FLAT HEAD SCREW #10 (2 1/2") / VIS À TÊTE PLATE # 10 (2 1/2")	4
25	CLEAR SETTING BLOCK (5/32") / BLOC NIVEAU TRANSPARENT (5/32")	4
26	CLEAR SETTING BLOCK (1/8") / BLOC NIVEAU TRANSPARENT (1/8")	4
27	ANTI-JUMP SHIM / CALE POUR L'ANTI-SAUT	2

1

**PLACE THE DOOR PANEL INSIDE THE TUB / PLACER LE PANNEAU DE PORTE DANS LA BAIGNOIRE**

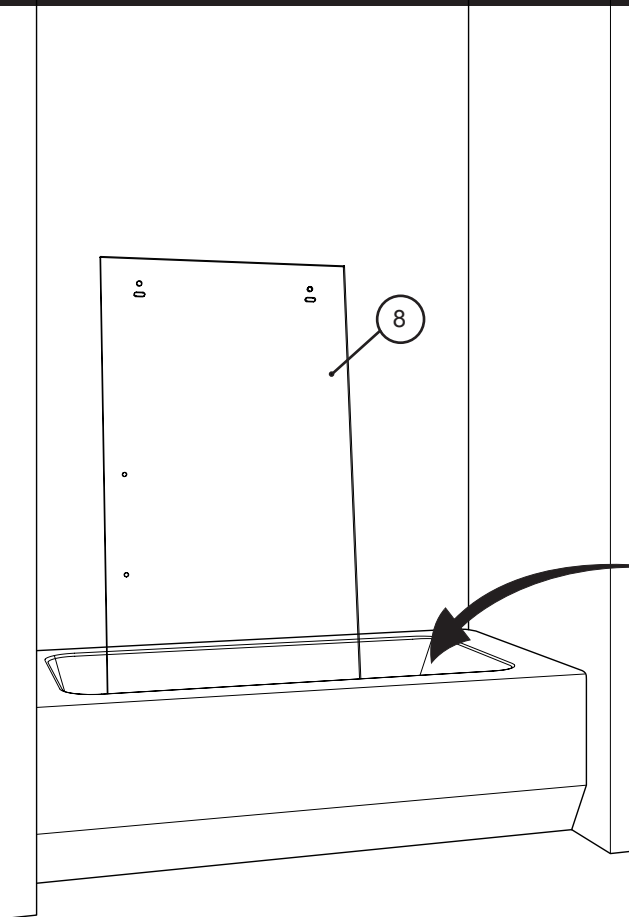

THE INSTALLATION SHOWN IS BASED ON PLUMB FINISHED WALLS AND A LEVELLED BASE. IF THESE CONDITIONS ARE NOT MET, PLEASE ADJUST ACCORDINGLY.

L'INSTALLATION ILLUSTRÉE EST BASÉE SUR DES MURS FINIS D'APLOMB ET UNE BASE DE DOUCHE NIVELÉE. SI CES CONDITIONS NE SONT PAS PRÉSENTÉES, VEUILLEZ AJUSTER EN CONSÉQUENCE.



PLACE THE DOOR ON A SOFT SURFACE TO PREVENT SCRATCHING THE TUB BASE.

PLACER LA PORTE SUR UNE SURFACE DOUCE POUR ÉVITER DE RAYER LA BASE DE LA BAIGNOIRE.

2

**PLACE U-CHANNEL & BOTTOM GUIDE ON THE BASE  
PLACER LE PROFILÉ EN "U" ET LE GUIDE INFÉRIEUR SUR LA BASE**

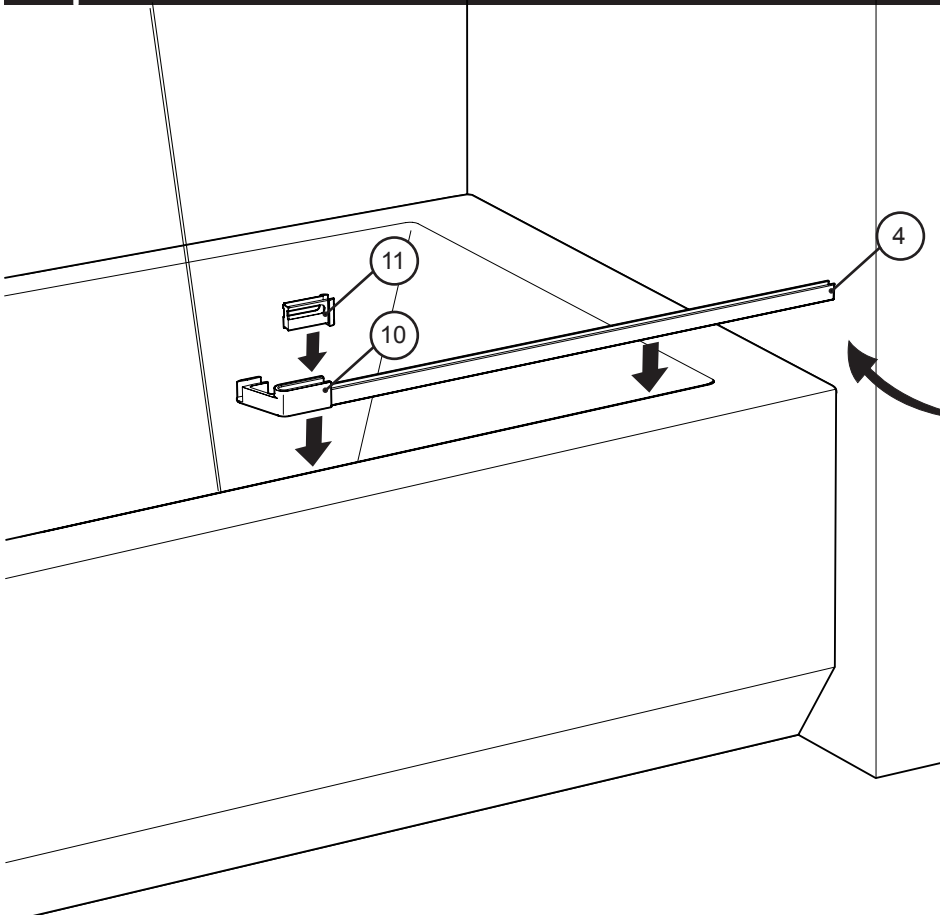

ENSURE THAT THE U-CHANNEL IS AGAINST THE WALL.

ASSURER QUE LE PROFILÉ EN "U" EST CONTRE LE MUR.

↑

**INTERIOR  
SHOWER SIDE**  
INTÉRIEUR  
DE LA DOUCHE

**TOP VIEW  
VUE DU HAUT**



**ENSURE THAT THE U-CHANNEL IS FULLY INSERTED INTO THE BOTTOM SLEEVE.**

ASSURER QUE LE PROFILÉ EN "U" EST COMPLÈTEMENT INSÉRÉ DANS LA GAINÉ PROTECTRICE INFÉRIEURE.

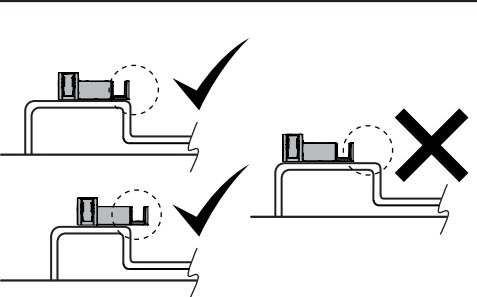



**SIDE VIEW / VUE LATÉRALE**

The bottom guide can hang off the base as long as it can be well fastened and is towards the inside of the shower.

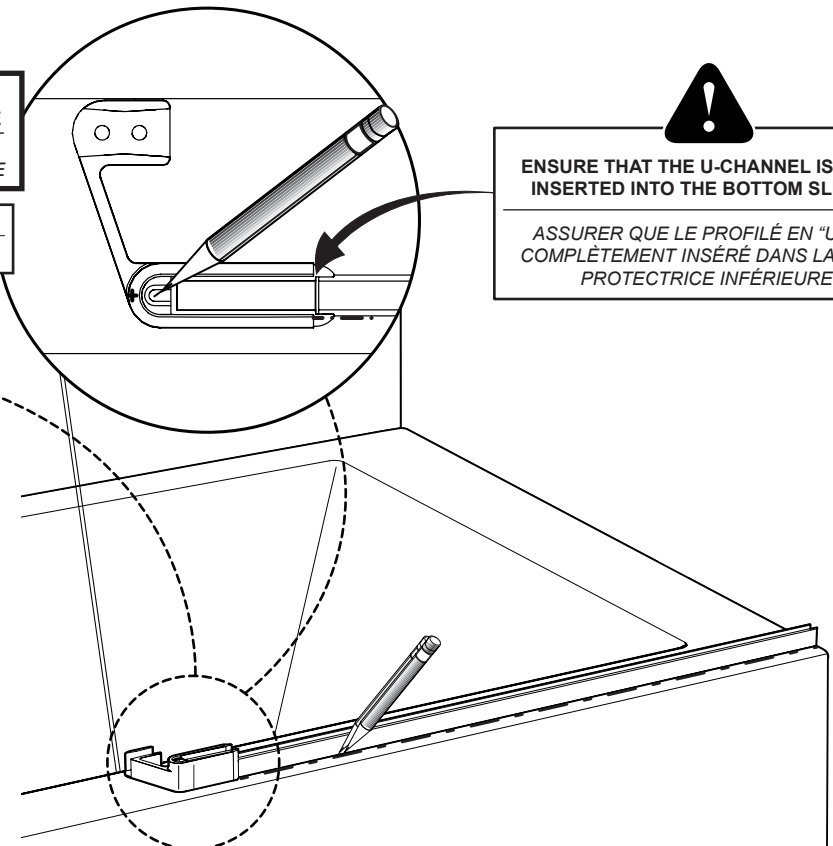
*Le guide inférieur peut dépasser la base en autant qu'il puisse être bien fixé et vers l'intérieur de la douche.*

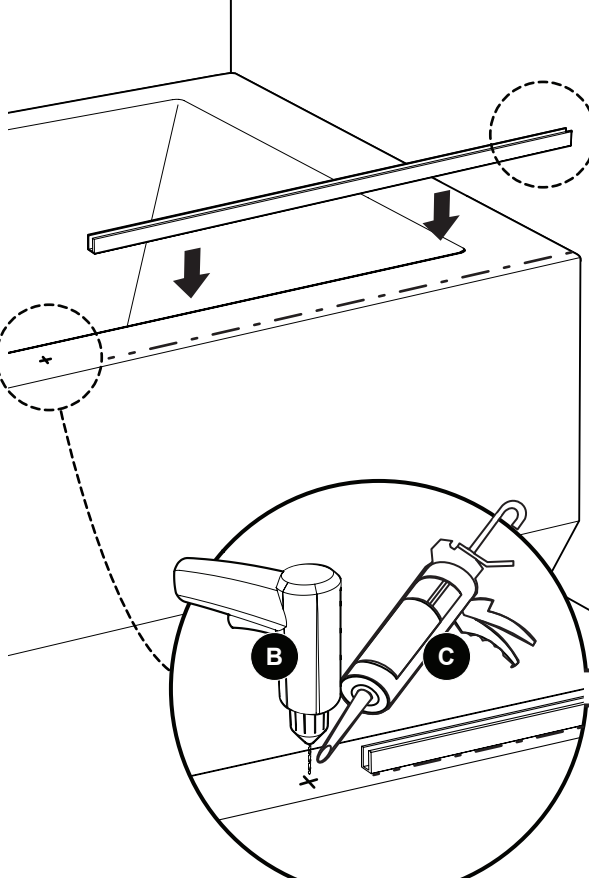





**WIPE THE BASE WITH A CLEAN CLOTH BEFORE INSTALLING THE U-CHANNEL.**

ESSUYER LA BASE AVEC UN CHIFFON PROPRE AVANT D'INSTALLER LE PROFILÉ EN "U".

**DO NOT TIGHTEN ALL THE WAY**  
NE PAS SERRER COMPLÈTEMENT

**A**

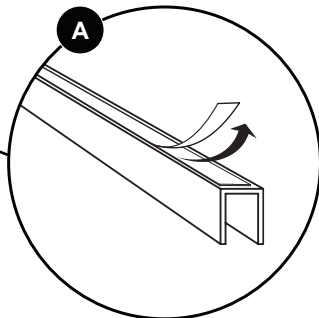

**B**

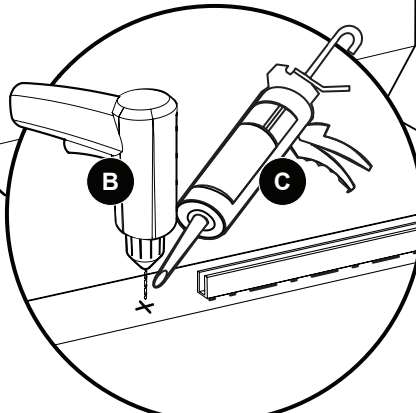

**C**

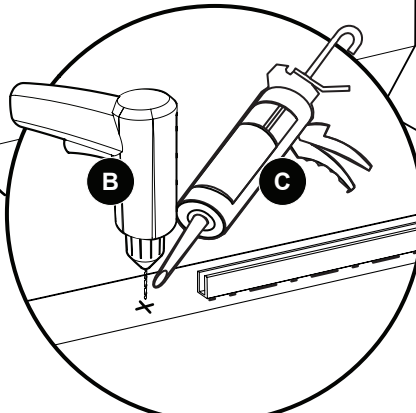

**D**

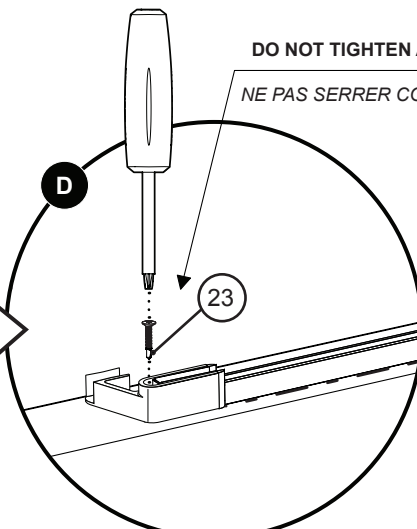

**E**

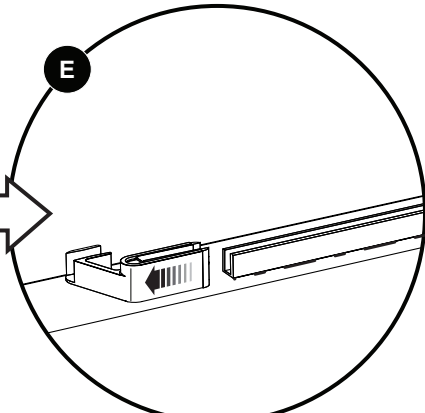

## MEASURE AND CUT THE BAR IF NECESSARY MESURER ET COUPER LA BARRE SI NÉCESSAIRE

- A** Calculate the length of the bar required using the formula provided.  
*Calculer la longueur de la barre requise en utilisant la formule fournie.*

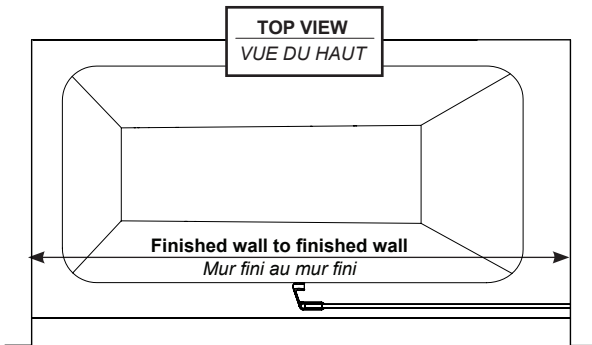

### FORMULA / FORMULE

bar length = subtract 1 5/8" (41mm) from the measurement of the finished wall to the finished wall

*longueur de la barre = soustraire 1 5/8" (41mm) de la mesure du mur fini au mur fini*

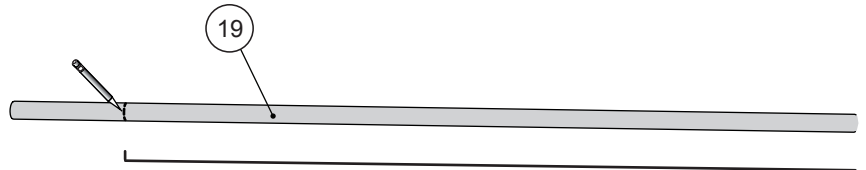

- B** Secure the bar with a table vise.  
*Sécuriser la barre dans un étau.*

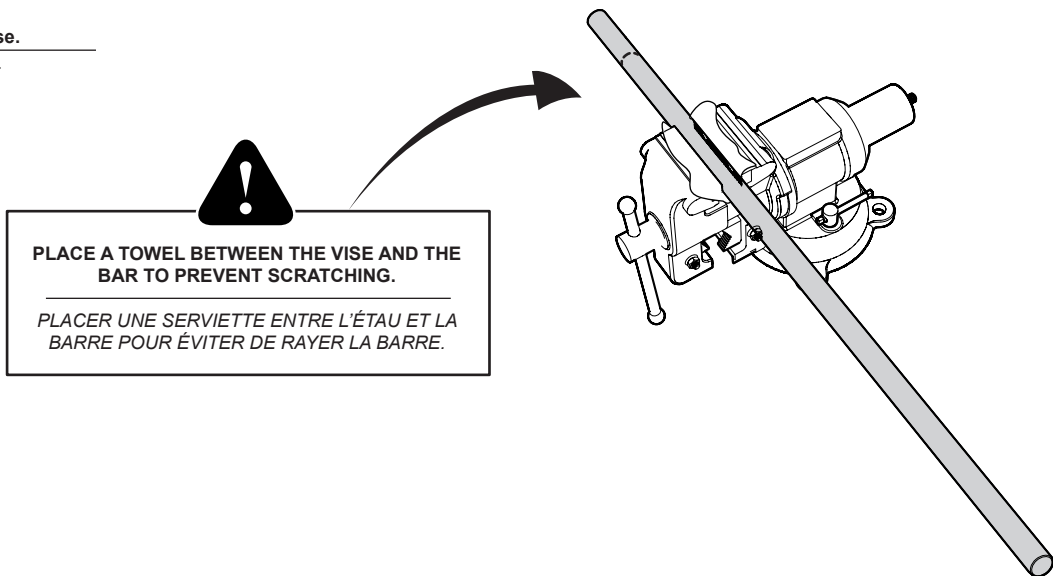

- C** Cut off the excess with the tube cutter.  
*Couper l'excès à l'aide du coupe-tube.*

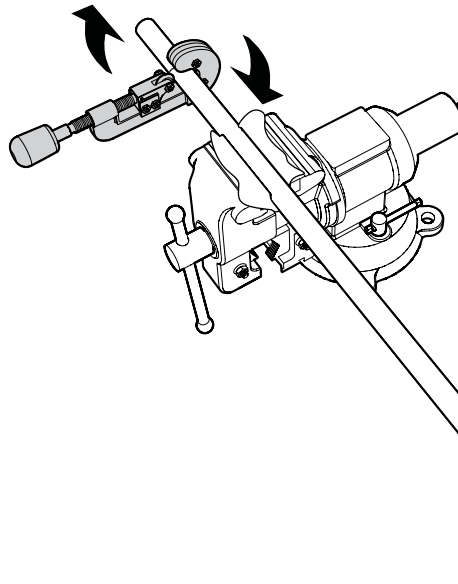





ENSURE THAT THE STOPPERS ARE  
POSITIONED AS SHOWN.

ASSURER QUE LES BUTOIRS SONT  
ORIENTÉS TELS QU'ILLUSTRÉS.

SIDE VIEW  
VUE LATÉRALE

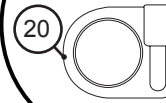

INTERIOR  
SHOWER SIDE  
INTÉRIEUR  
DE LA DOUCHE

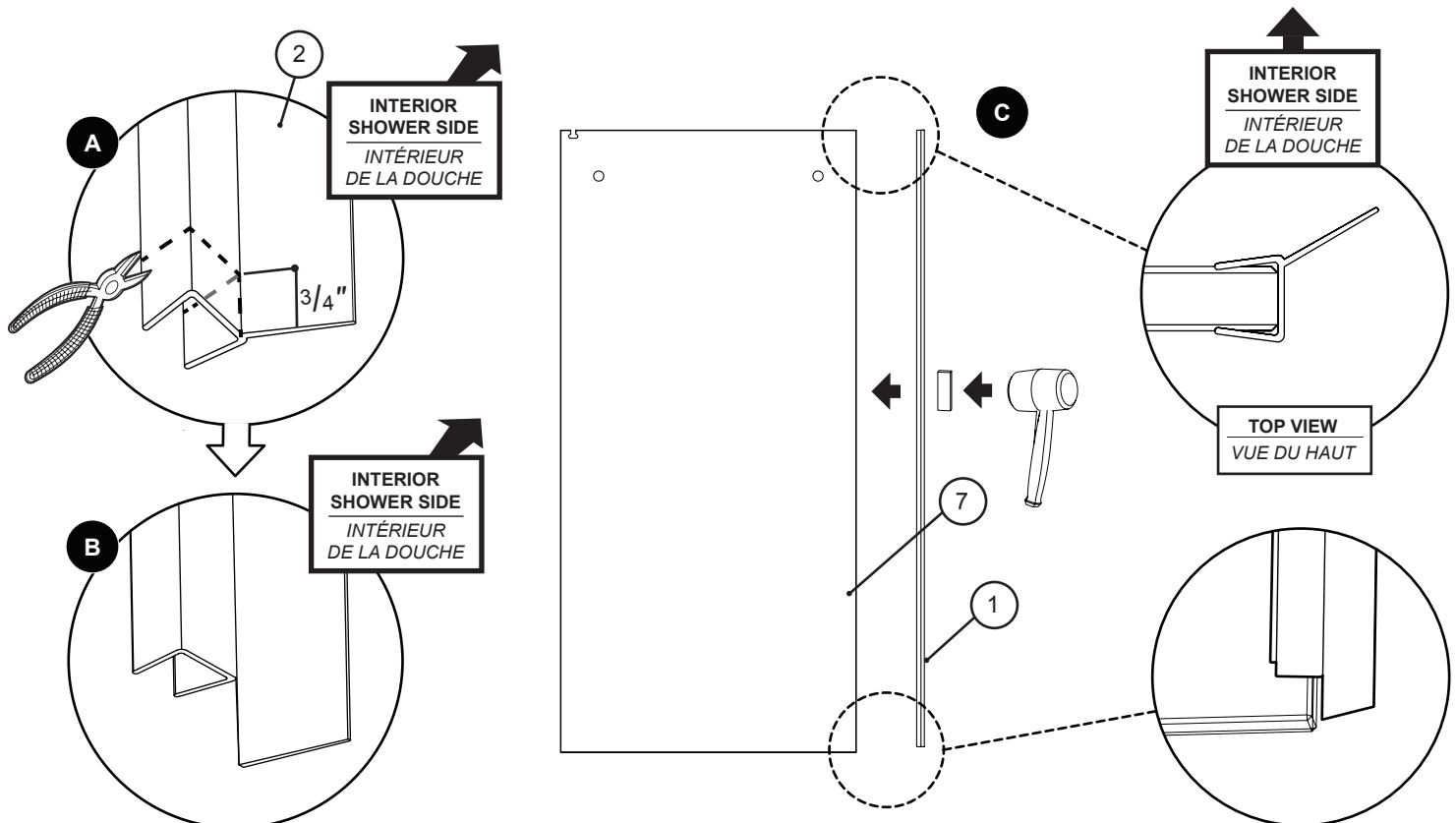
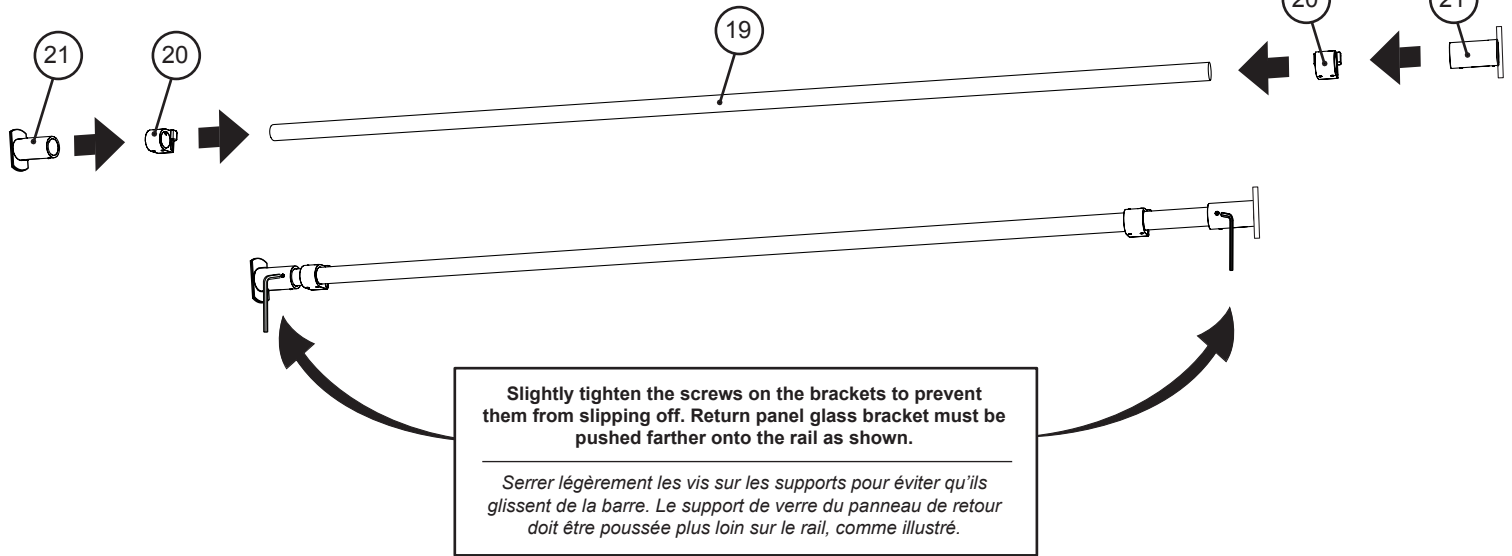

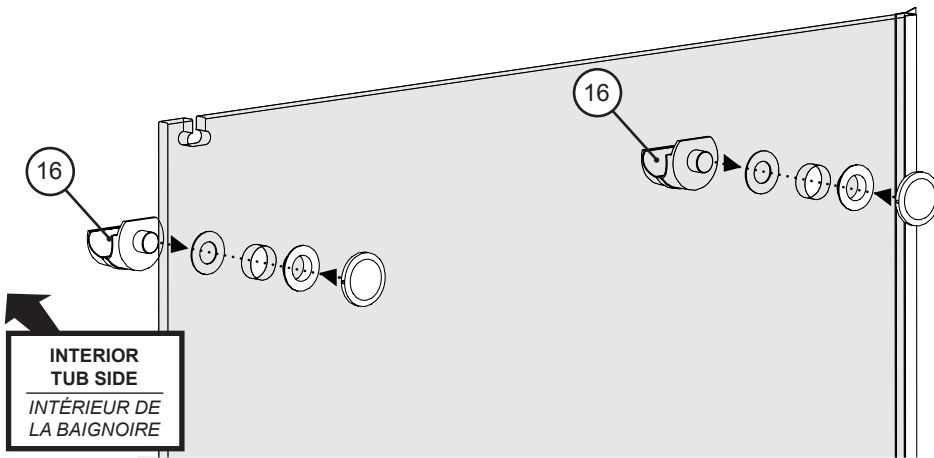

ENSURE THAT EACH GLASS FASTENER IS CENTERED IN THE FIXED PANEL HOLE.

ASSURER QUE LA FIXATION DE VERRE EST CENTRÉE DANS LE TROU DU PANNEAU FIXE.

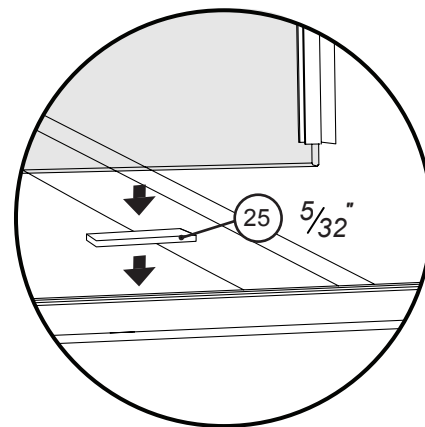
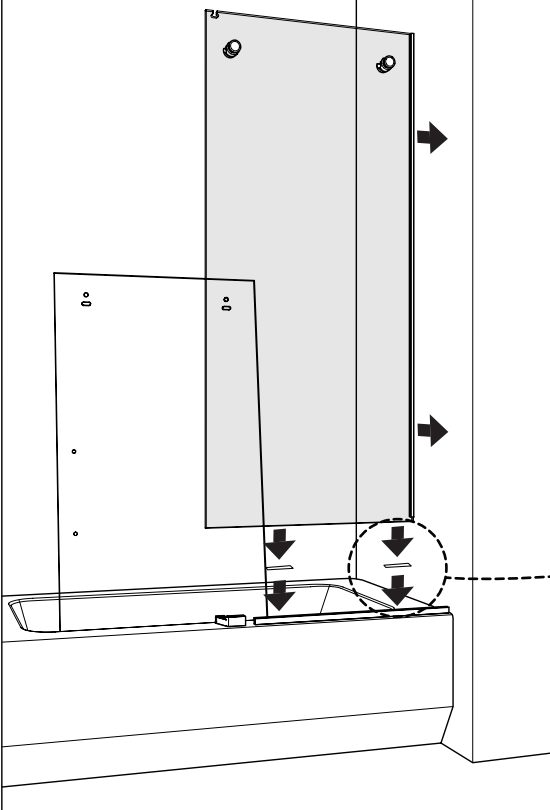
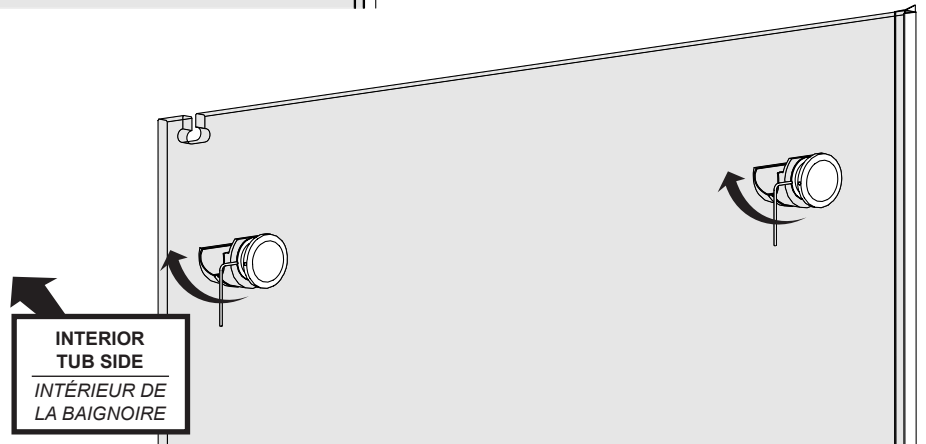

10

**IF POSSIBLE, FULLY TIGHTEN THE THE BOTTOM GUIDE SCREW**  
*SI POSSIBLE, BIEN VISSER LA VIS DU GUIDE INFÉRIEUR*

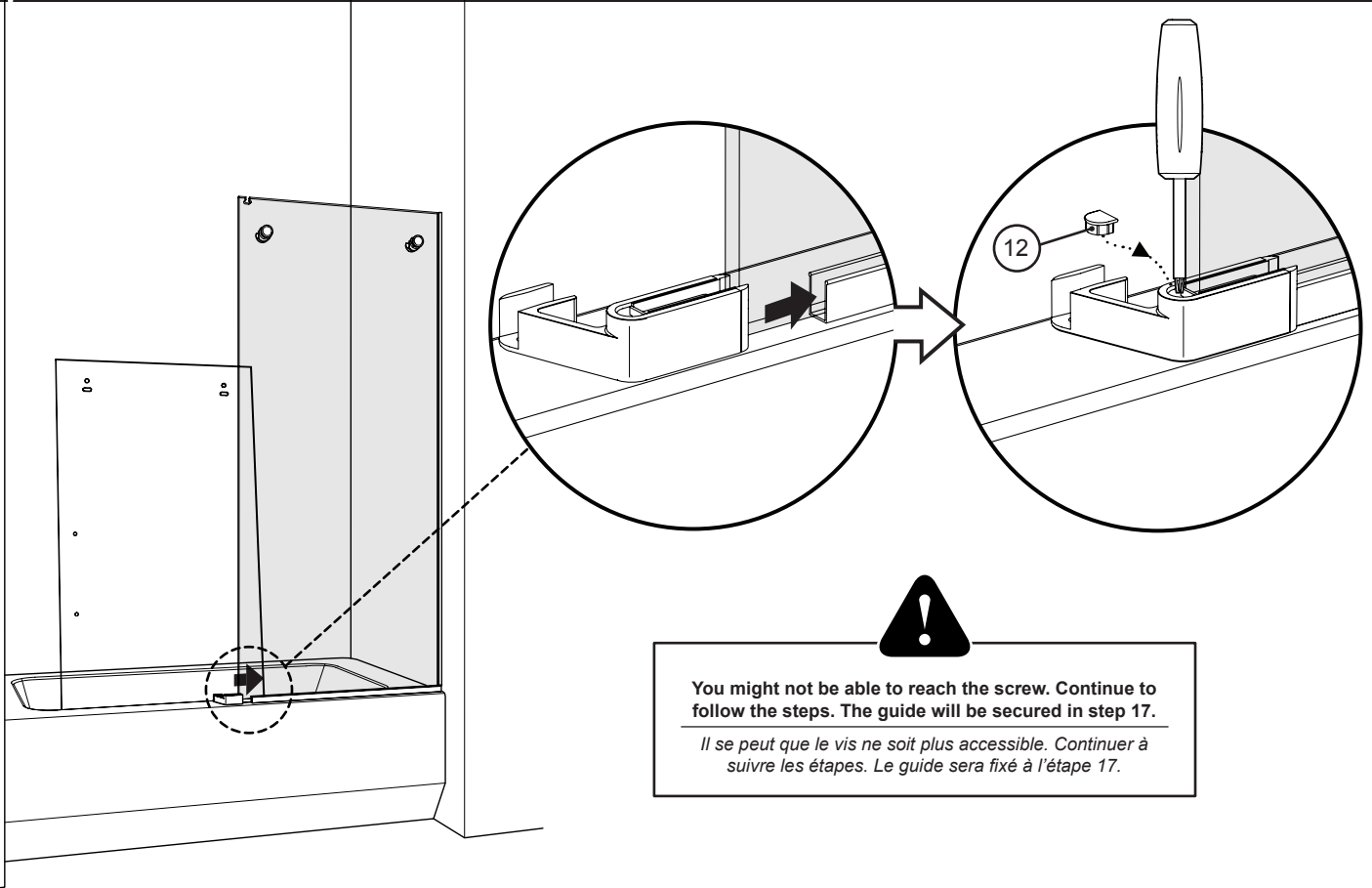

11

**INSTALL THE RUNNING RAIL ONTO THE FASTENERS**  
*INSTALLER LA BARRE DE ROULEMENT SUR LES FIXATIONS DE VERRE*

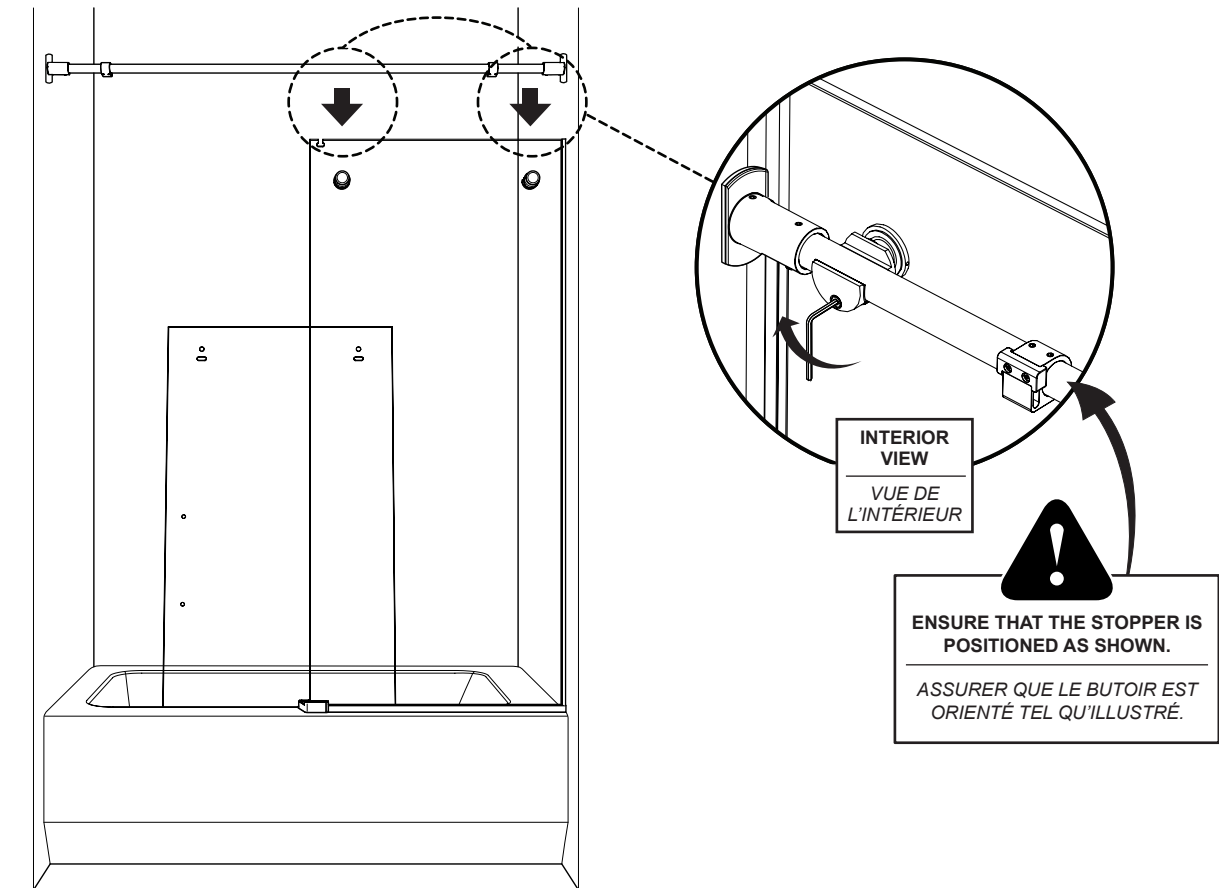

12

**LEVEL AS SHOWN BELOW & ADJUST IF NECESSARY**  
*NIVELER TEL QU'ILLUSTRÉ CI-DESSOUS ET AJUSTER SI NÉCESSAIRE*

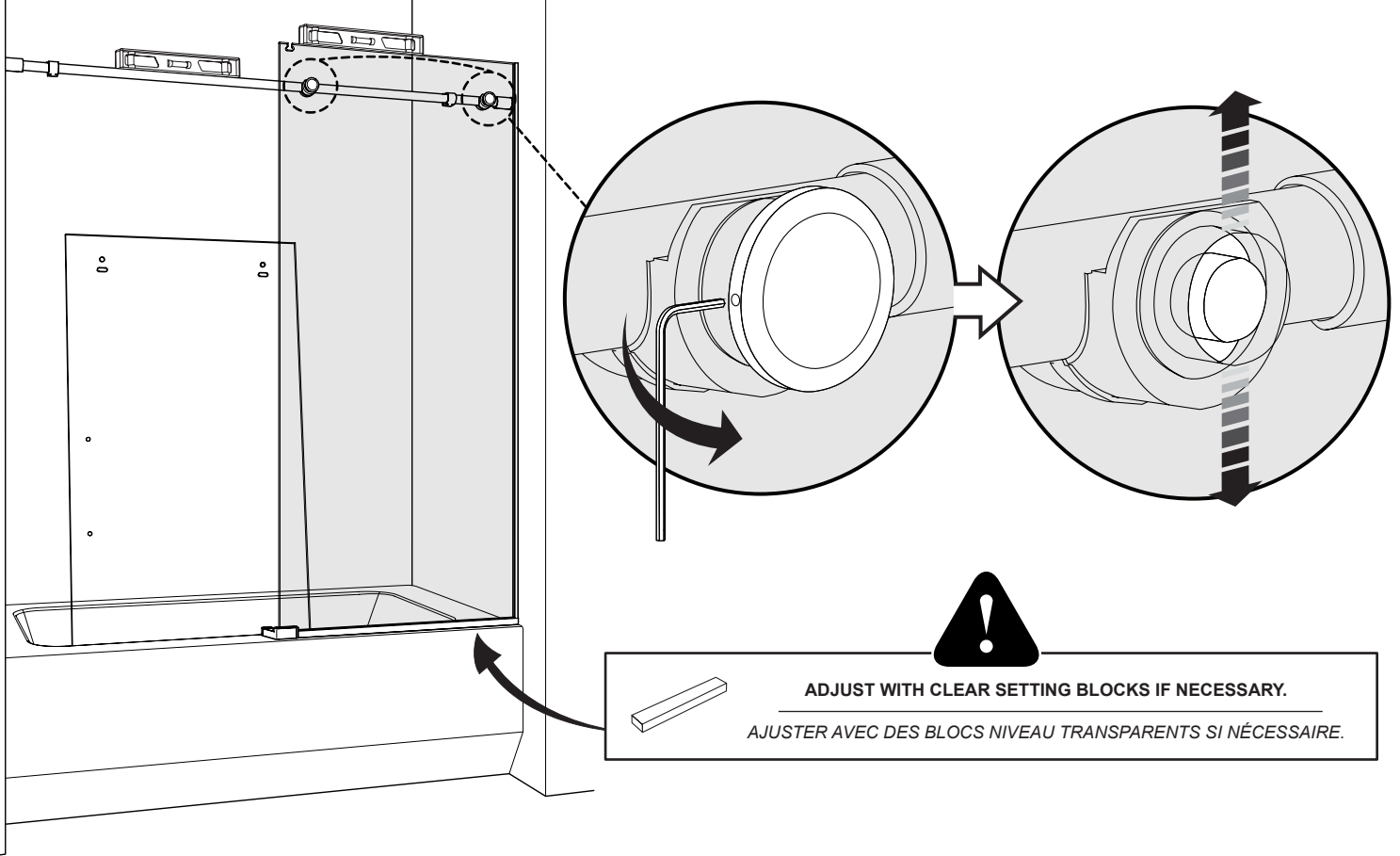

13

**LEVEL FIXED PANEL & MARK BRACKET LOCATION**  
*NIVELER LE PANNEAU FIXE ET MARQUER LA POSITION DES SUPPORTS*

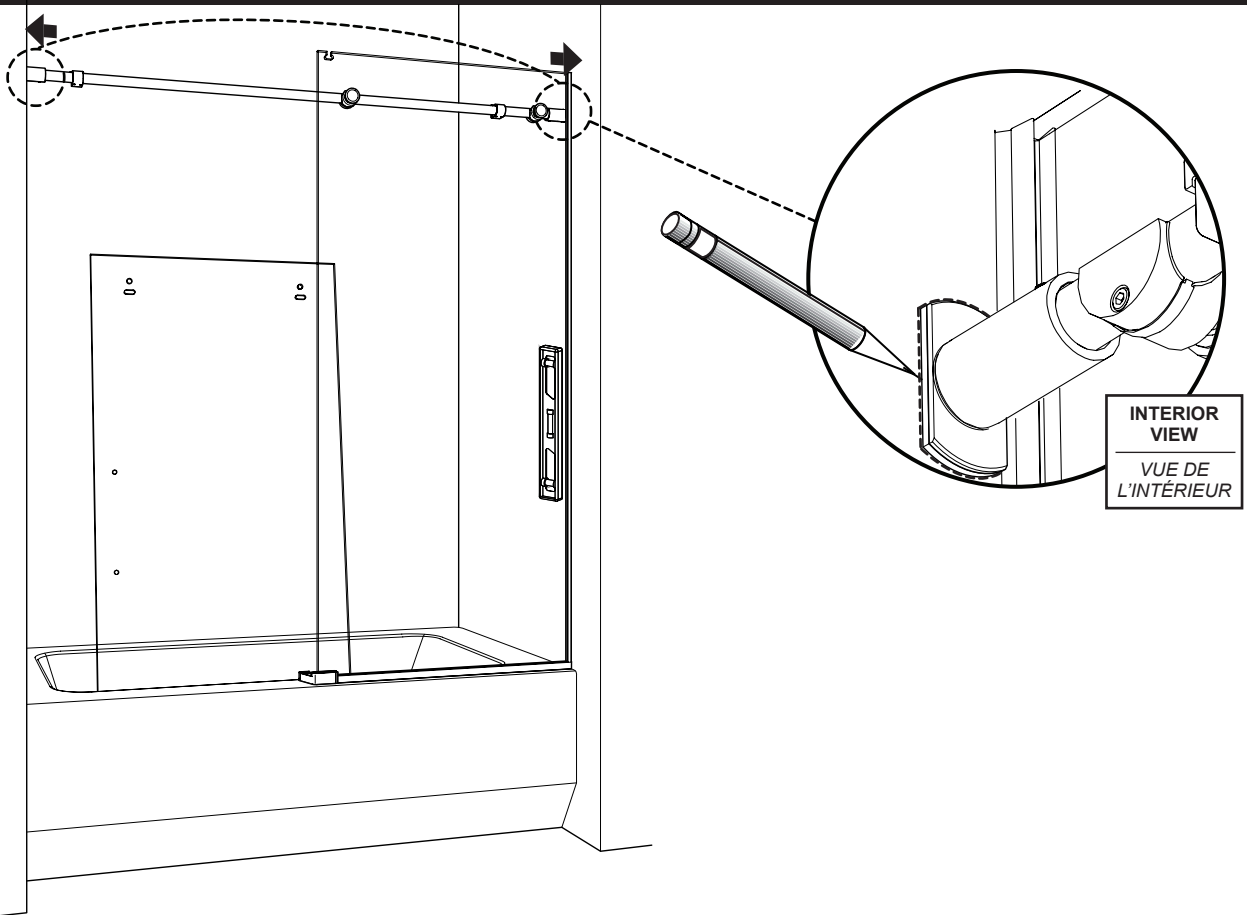

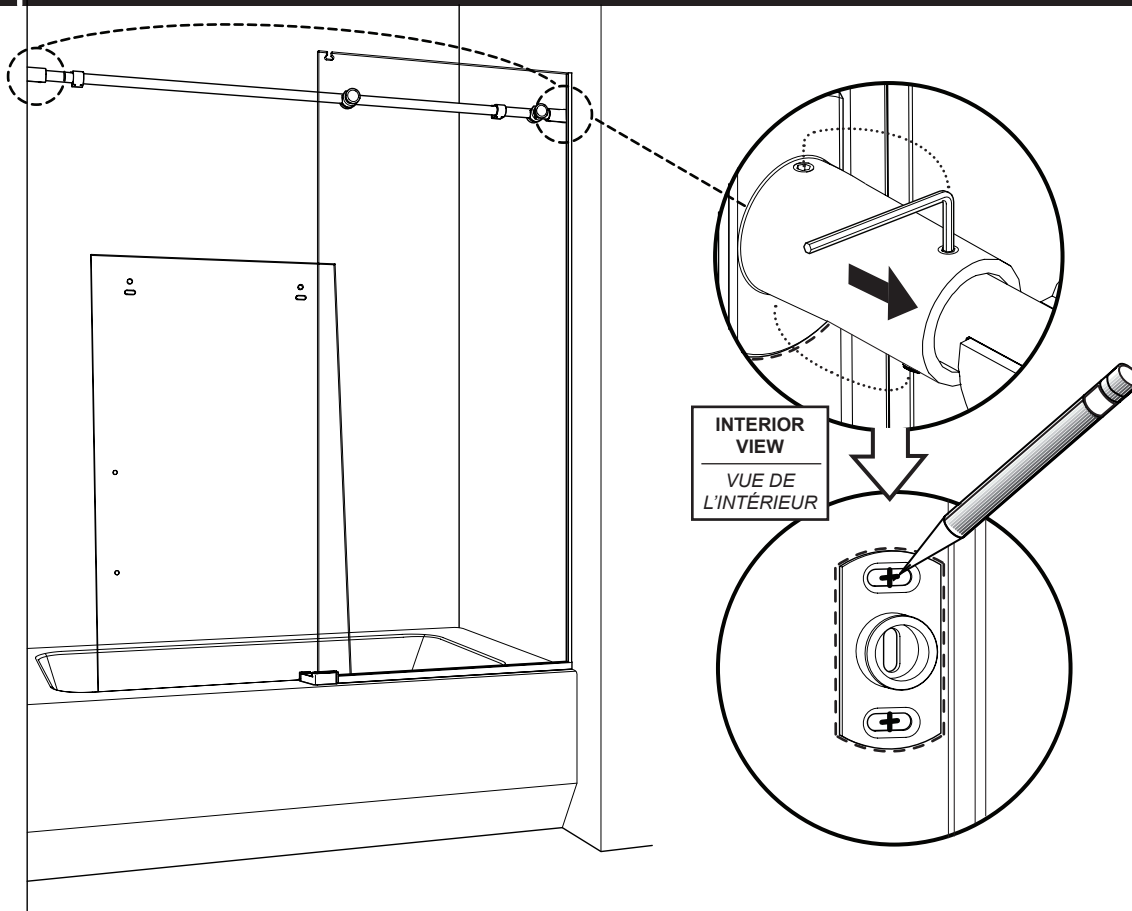

LOOSEN THE SCREWS AND  
REMOVE THE BRACKET  
FROM THE BACK PLATE.

DÉVISSER LÉGÈREMENT ET  
RETIRER LE SUPPORT DE  
LA PLAQUE MURALE.

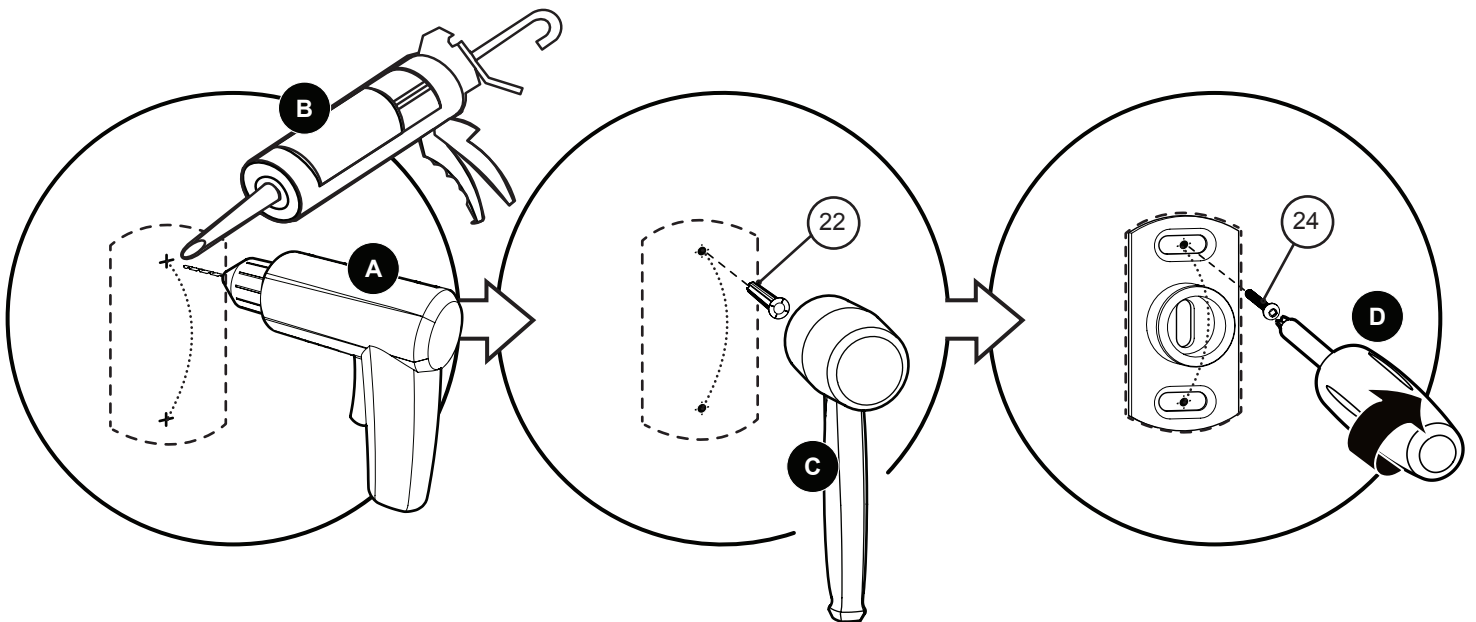

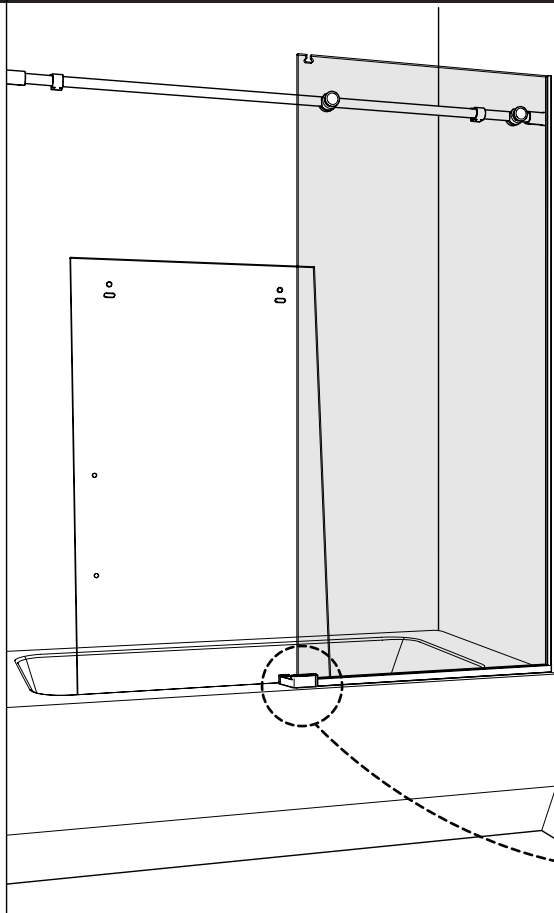
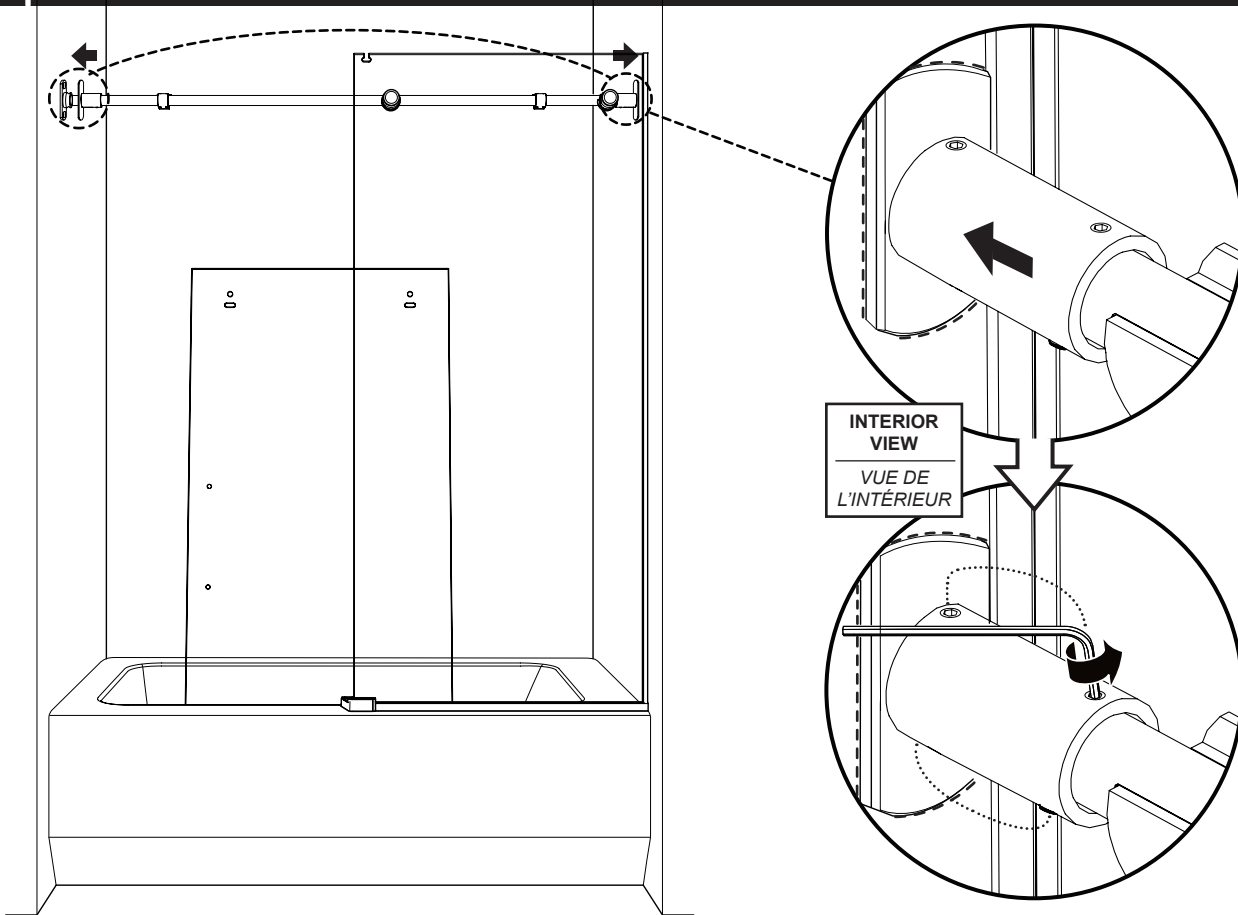

**!**

**SECURE THE BOTTOM GUIDE USING THE SCREWS WITH NYLON BACKINGS.**

---

*SÉCURISER LE GUIDE INFÉRIEUR EN UTILISANT LES VIS AVEC LE REVÊTEMENT EN NYLON.*

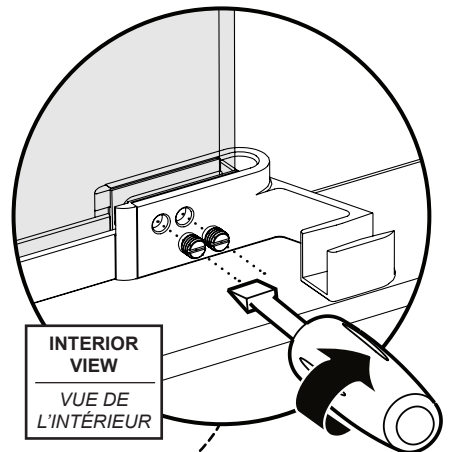

18

**INSTALL THE ANTI-JUMPS ONTO THE DOOR / INSTALLER LES ANTI-SAUTS SUR LA PORTE**

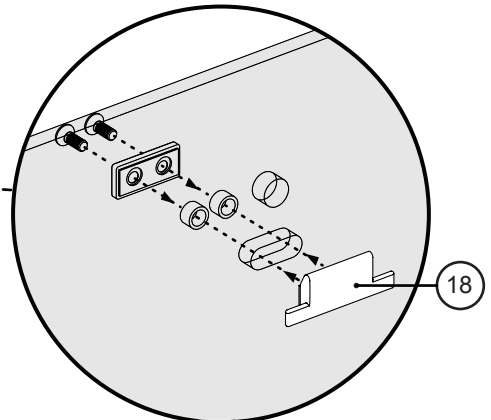
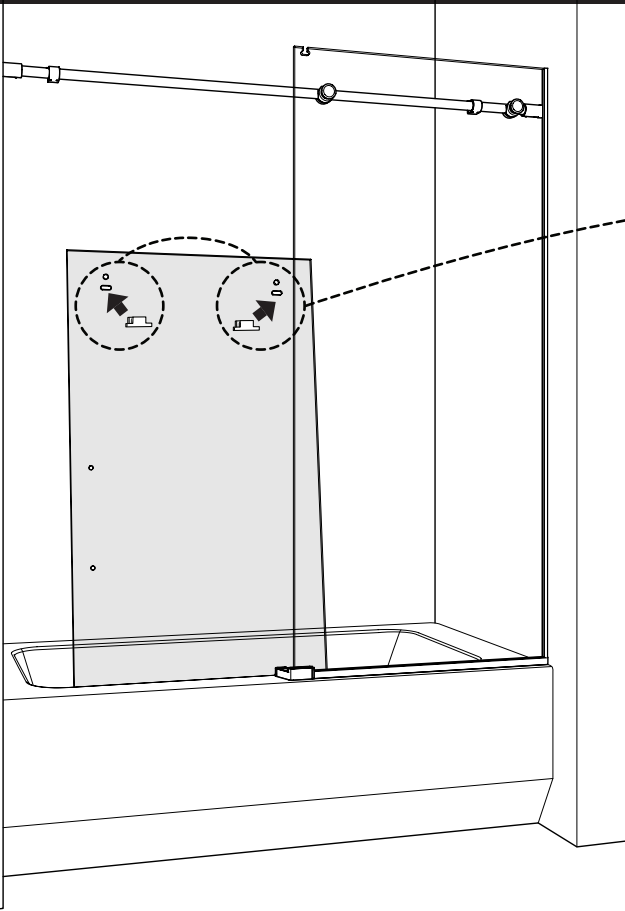

INTERIOR VIEW  
VUE DE L'INTÉRIEUR

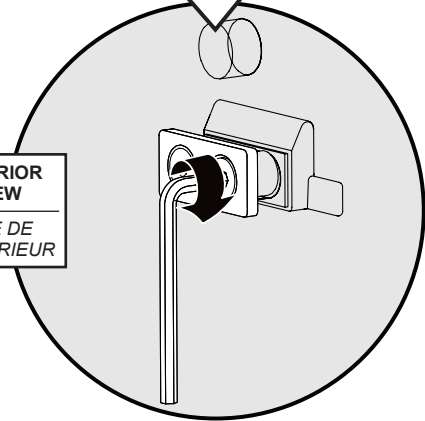

19

**INSTALL THE ROLLERS ONTO THE DOOR / INSTALLER LES ROULETTES SUR LA PORTE**

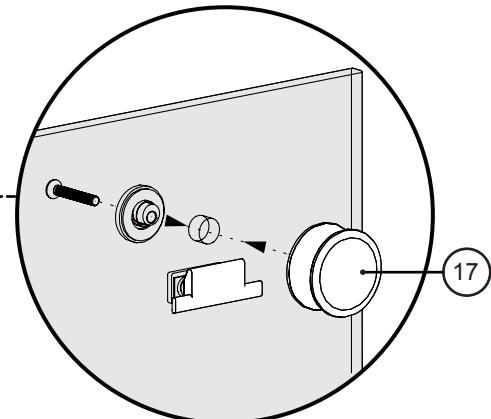
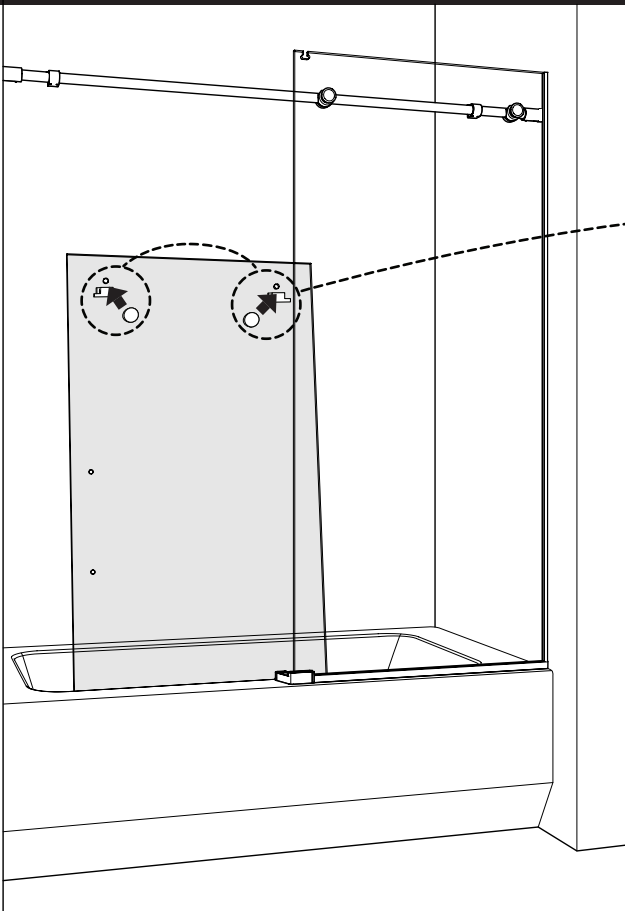

REFERENCE DOT UPWARDS  
POINT DE RÉFÉRENCE  
VERS LE HAUT

INTERIOR VIEW  
VUE DE L'INTÉRIEUR

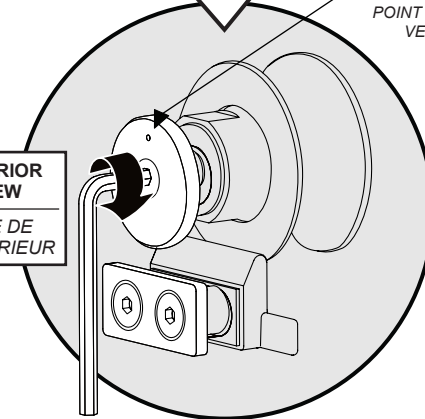

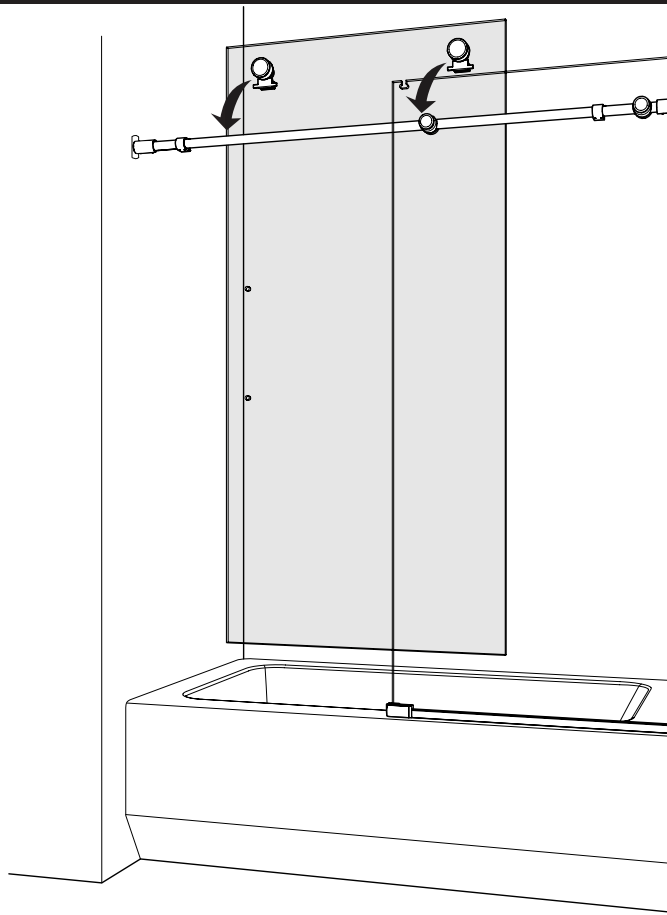

21 INSTALL THE GASKETS AS SHOWN BELOW / INSTALLER LES JOINTS TELS QU'ILLUSTRÉS CI-DESSOUS

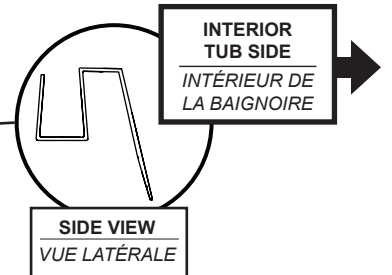
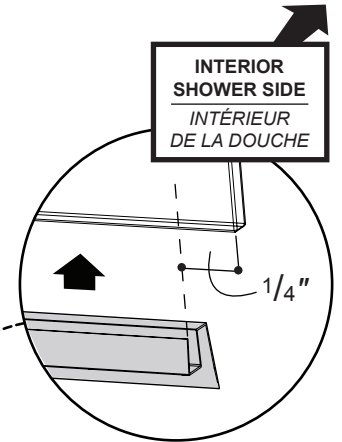
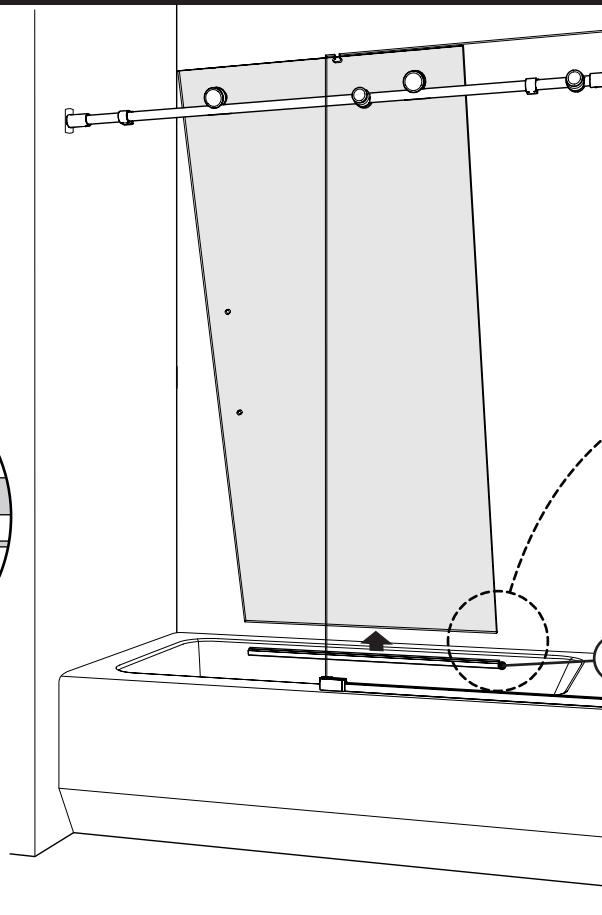
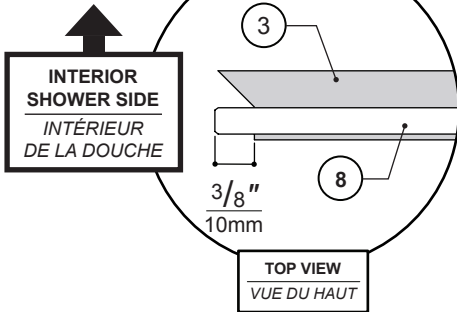
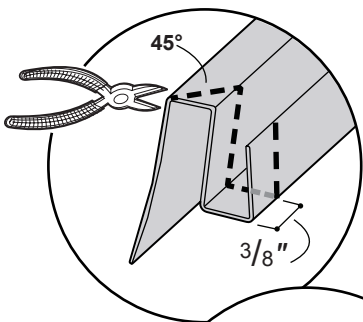



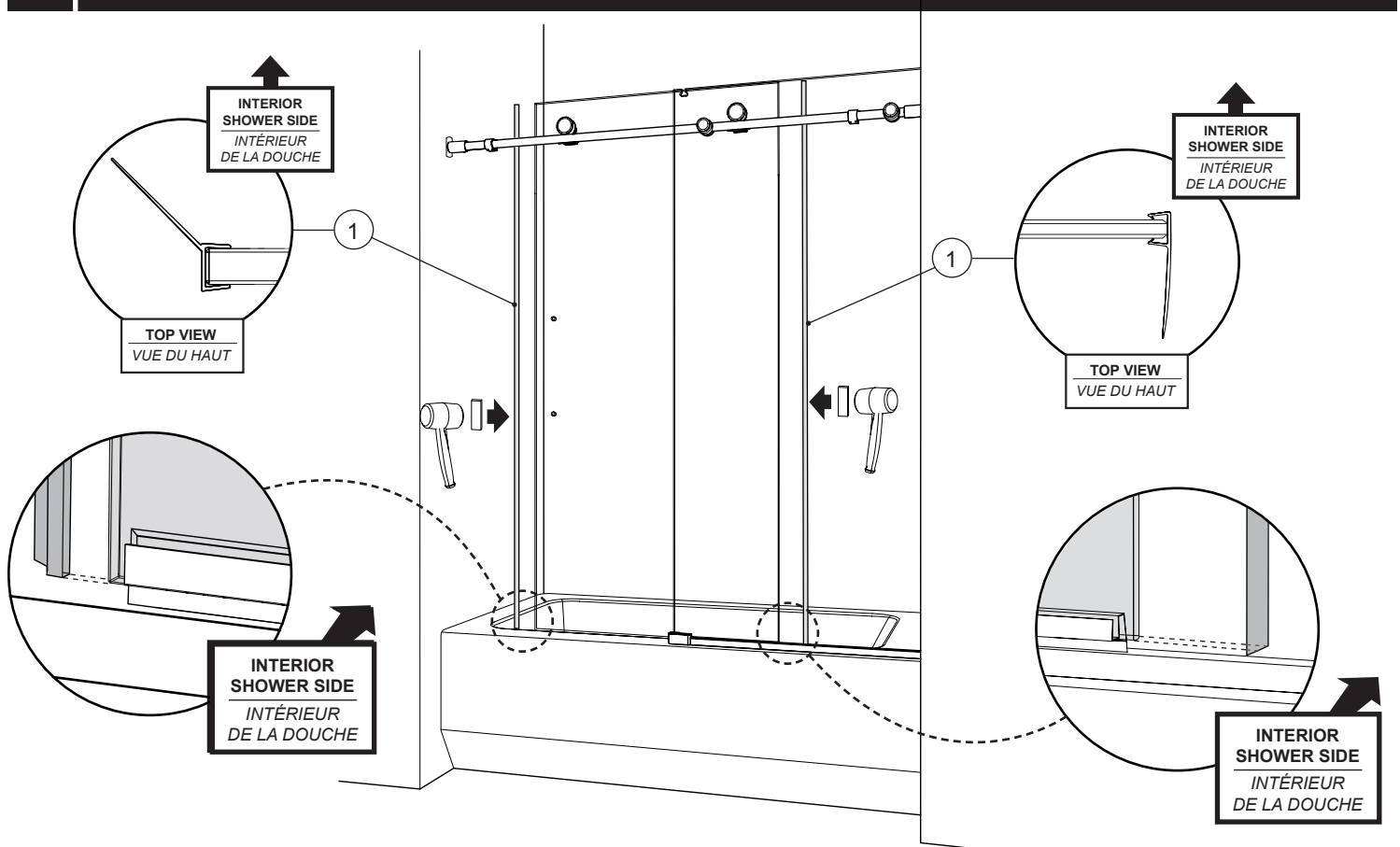
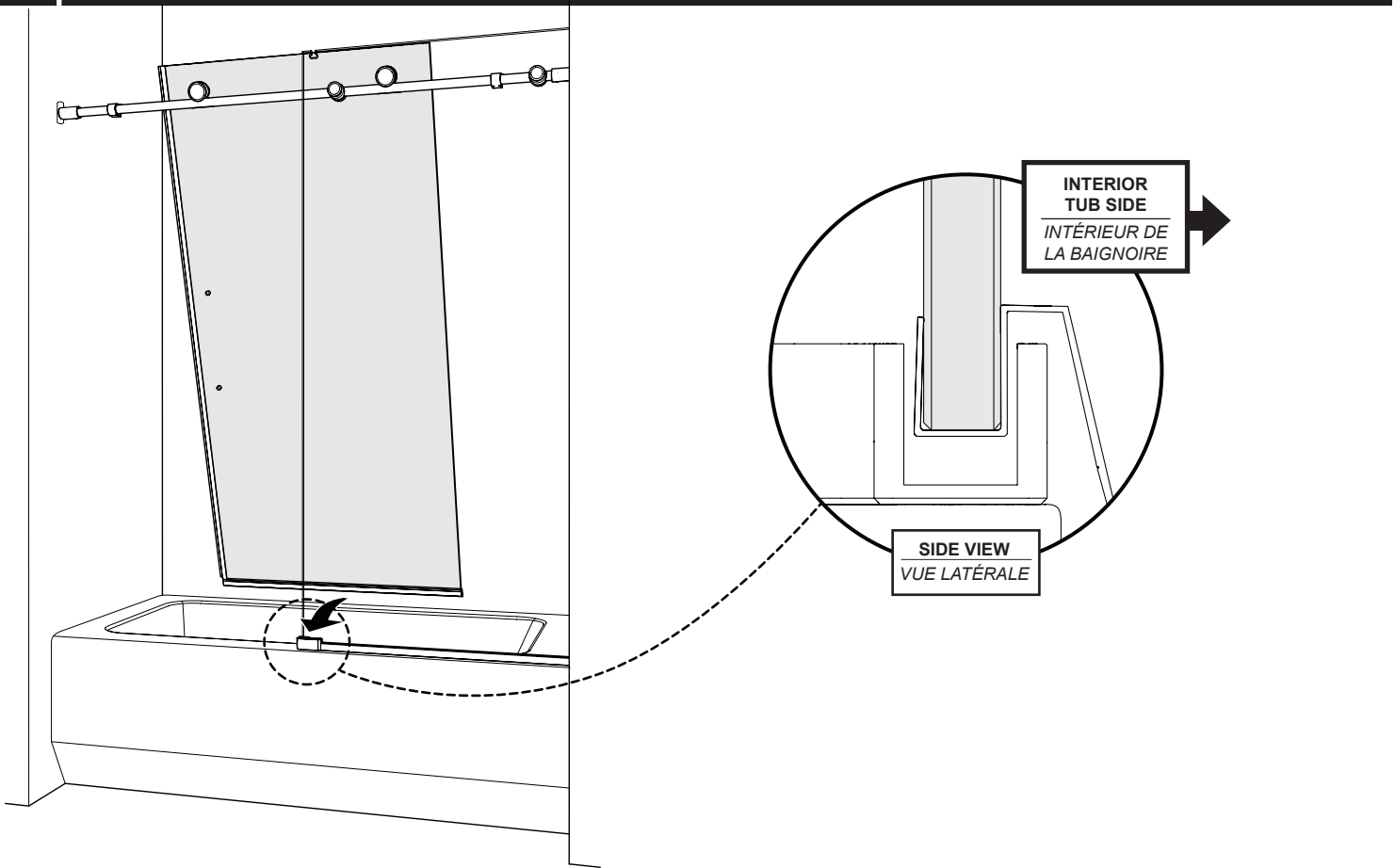

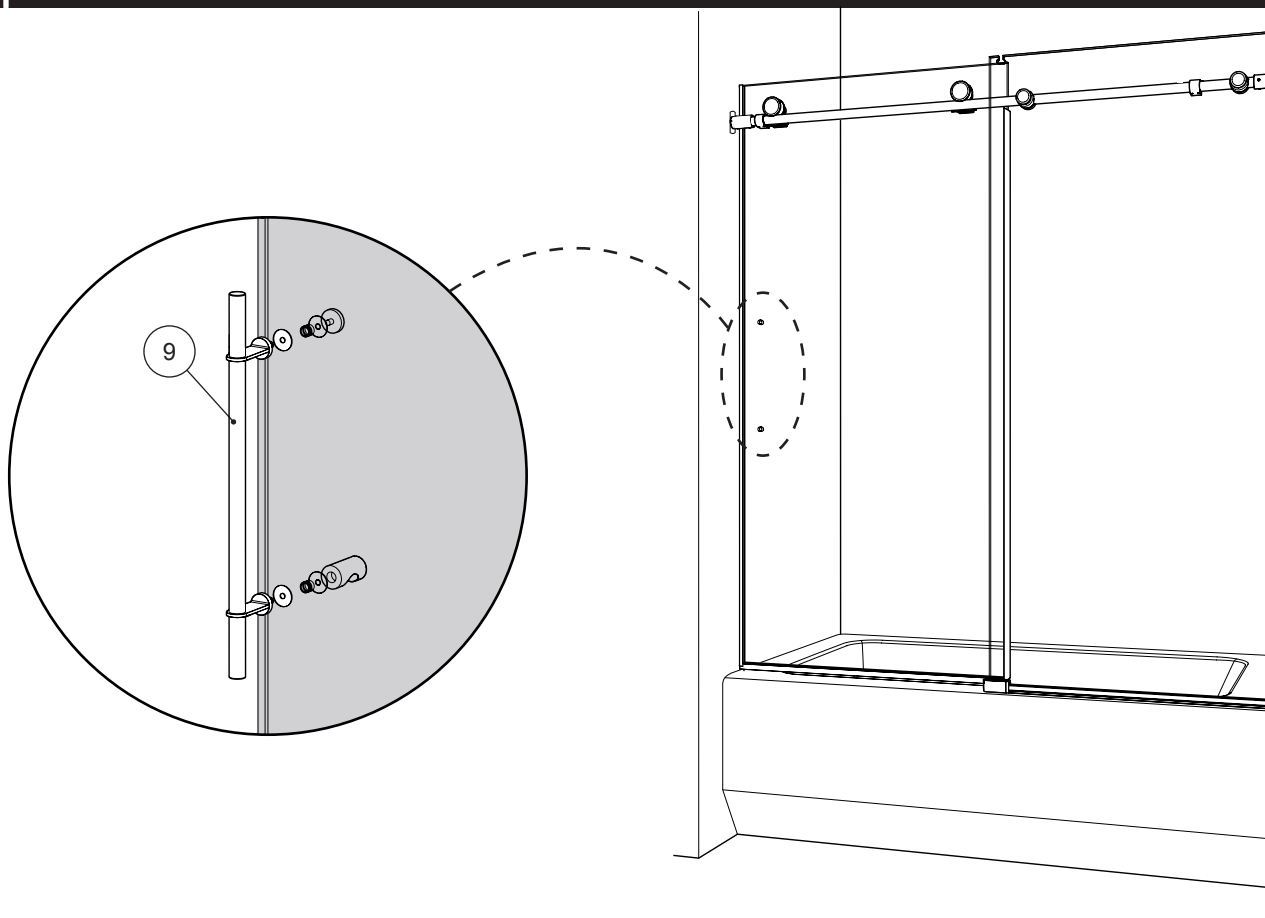
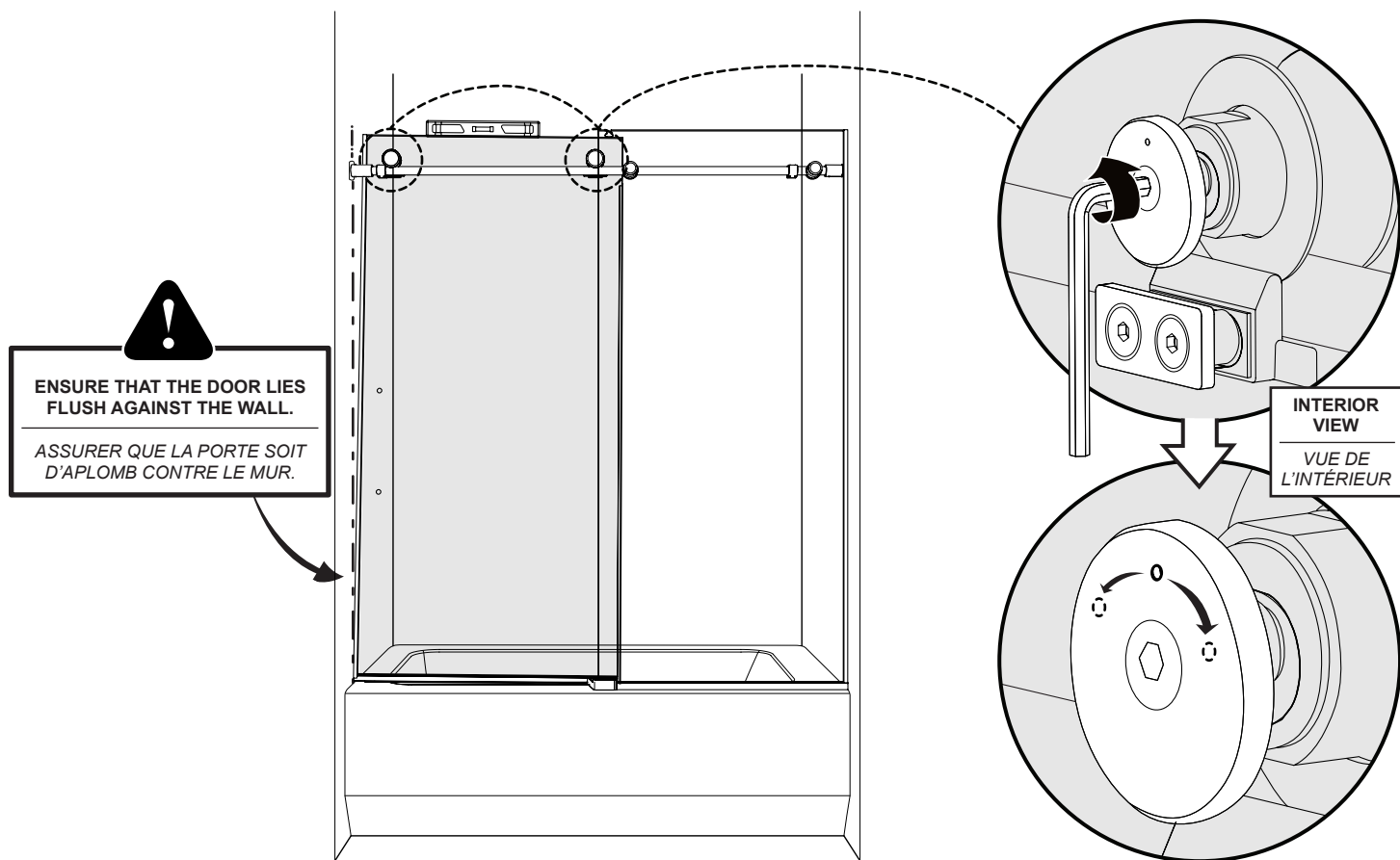

POSITION THE STOPPER SO THAT IT LIES FLUSH WITH THE ANTI-JUMP WHEN THE DOOR IS IN THE CLOSED POSITION.

POSITIONNER LE BUTOIR DE SORTE QU'IL REPOSE AU RAS AVEC L'ANTI-SAUT LORSQUE LA PORTE EST DANS LA POSITION FERMÉE.

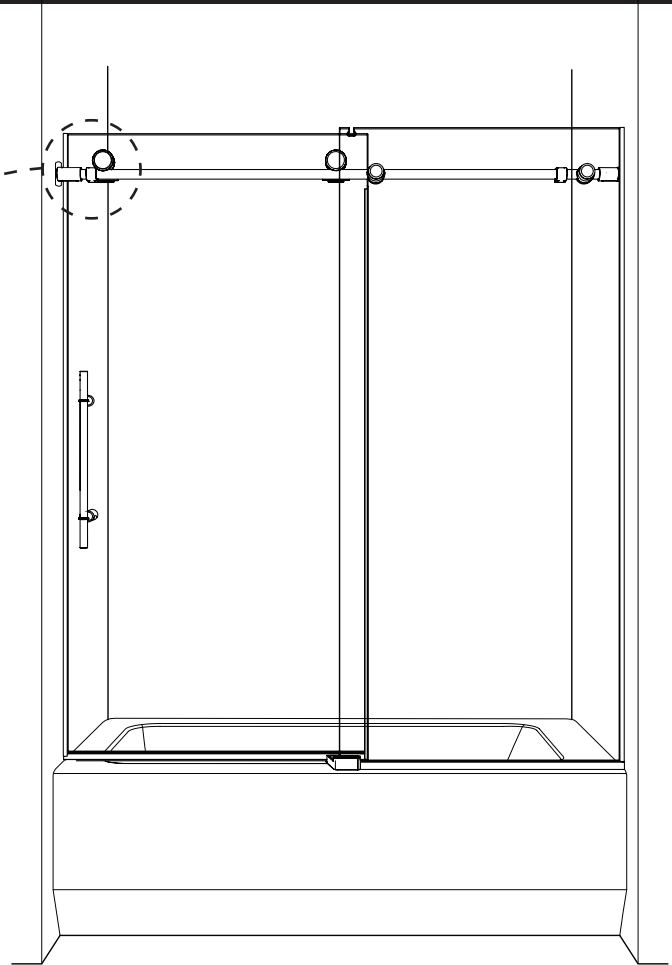
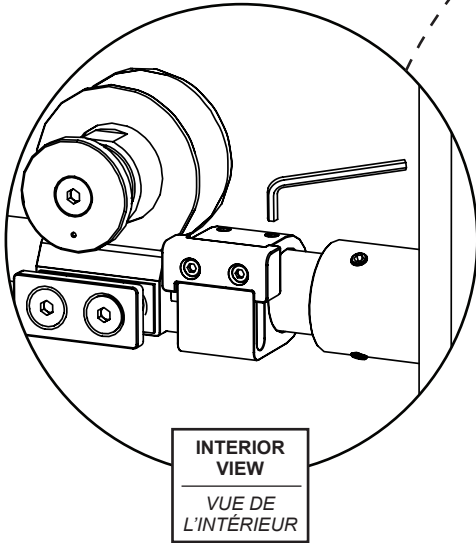

POSITION THE STOPPER SO THAT IT PREVENTS THE HANDLE FROM HITTING THE FIXED PANEL WHEN THE DOOR IS OPEN. ⚠

POSITIONNER LE BUTOIR DE SORTE QU'IL EMPÊCHE LA POIGNÉE DE FRAPPER LE PANNEAU FIXE QUAND LA PORTE EST OUVERTE. ⚠

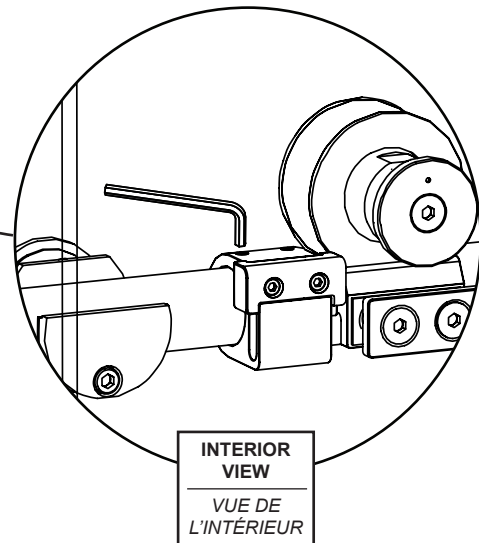
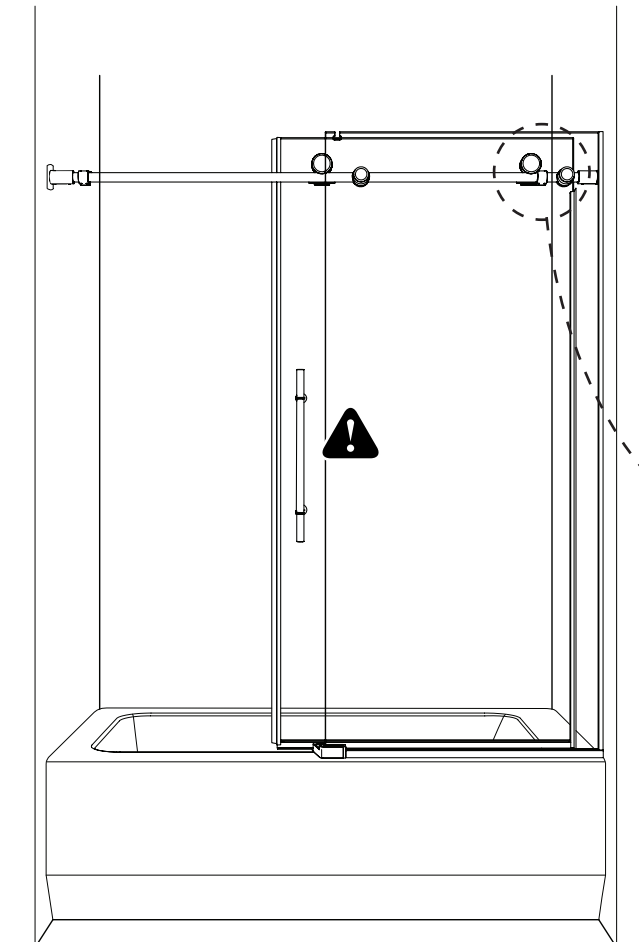

**27 ADD A SHIM TO THE ANTI-JUMP IF NECESSARY / AJOUTER UNE CALE À L'ANTI-SAUT SI NÉCESSAIRE**

**!**

The anti-jump should be centered in the hole where it intersects the stopper. If the anti-jump is rubbing against the stopper, add a shim.

*L'anti-saut doit être centré dans le trou où il se croise avec le butoir. Si l'anti-saut se frotte contre le butoir, ajouter une cale.*

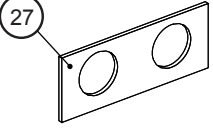

**!**

INTERIOR SHOWER SIDE  
INTÉRIEUR DE LA DOUCHE

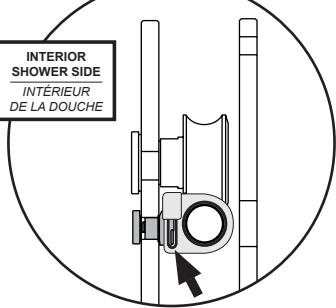
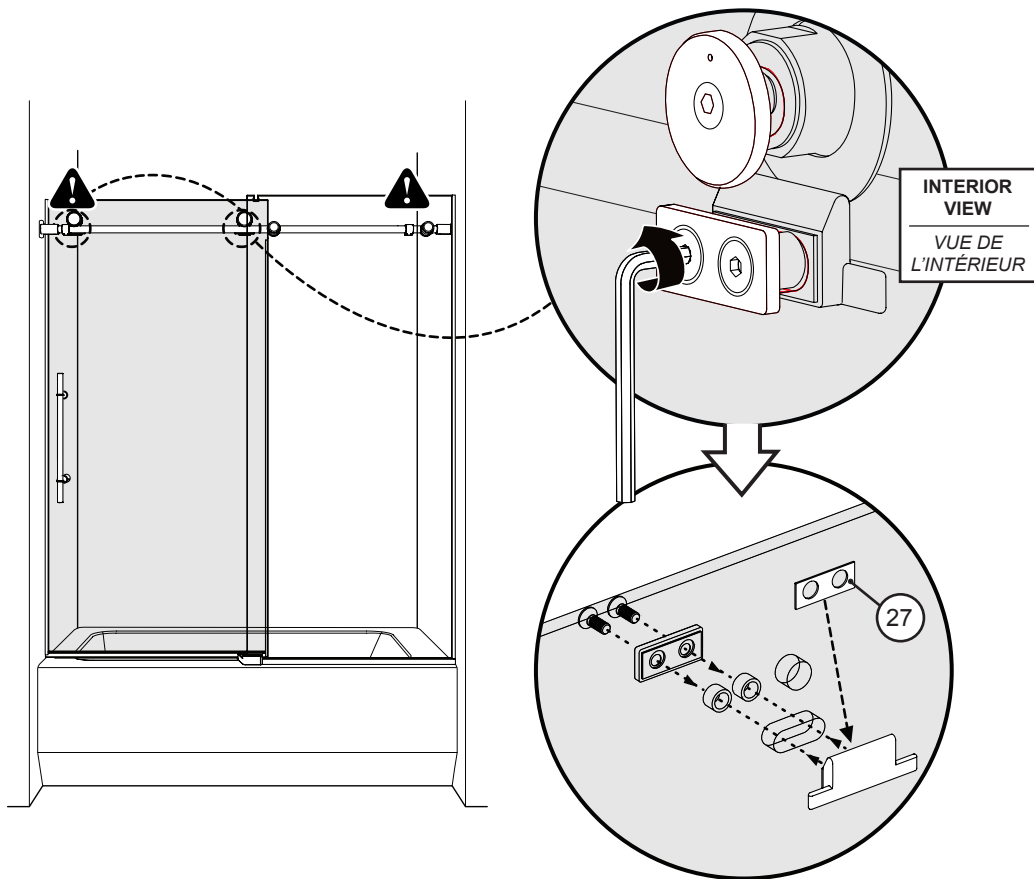
INTERIOR VIEW  
VUE DE L'INTÉRIEUR

**28 CUT GASKET IF NECESSARY / COUPER LE JOINT SI NÉCESSAIRE**

**!**

CUT THE GASKET AS SHOWN IF IT IS RUBBING AGAINST THE STOPPER.

*SI LE JOINT FROTTE LE BUTOIR, IL FAUT LE COUPER TEL QU'ILLUSTRÉ.*

INTERIOR VIEW  
VUE DE L'INTÉRIEUR

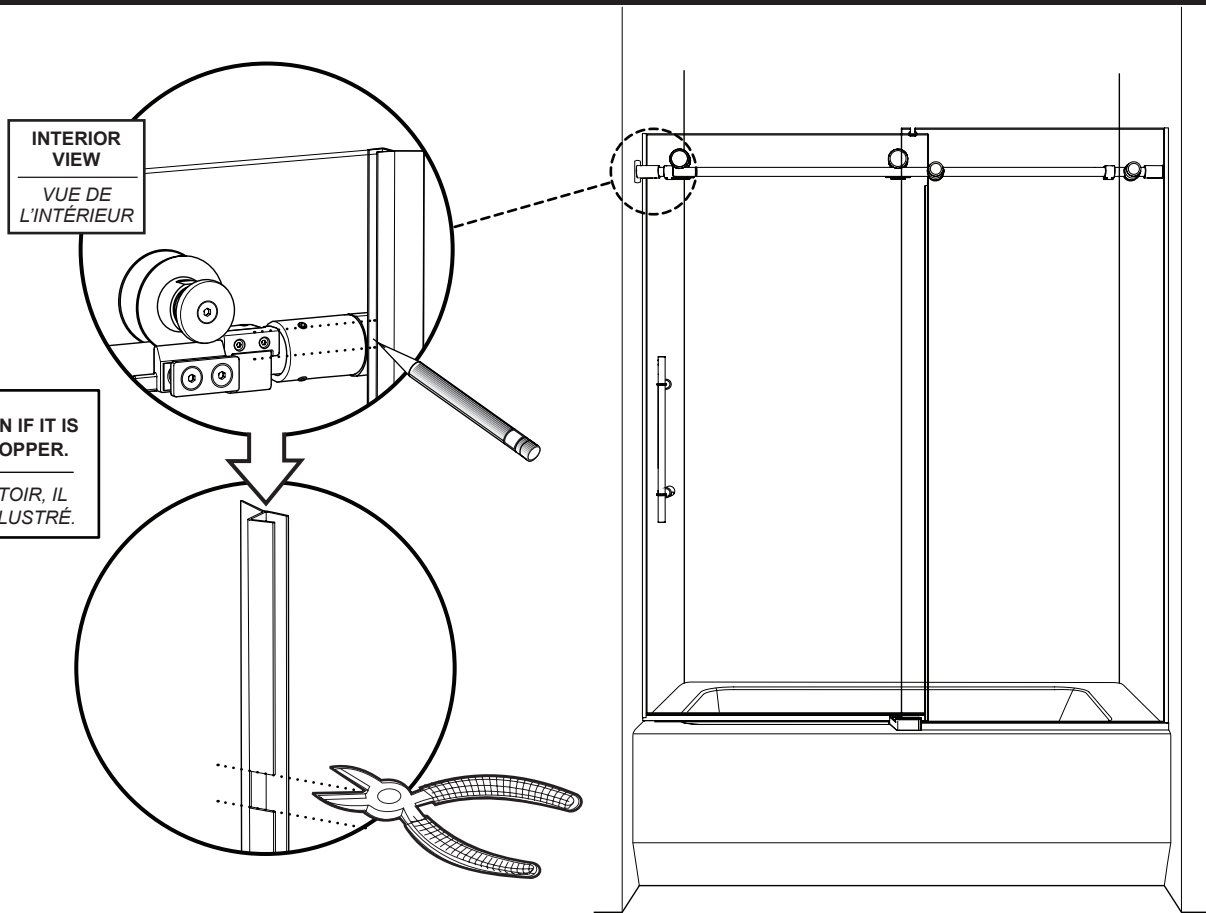

SECURE WITH A DROP  
OF SUPER GLUE

SÉCURISER AVEC UNE  
GOUTTE DE COLLE FORTE

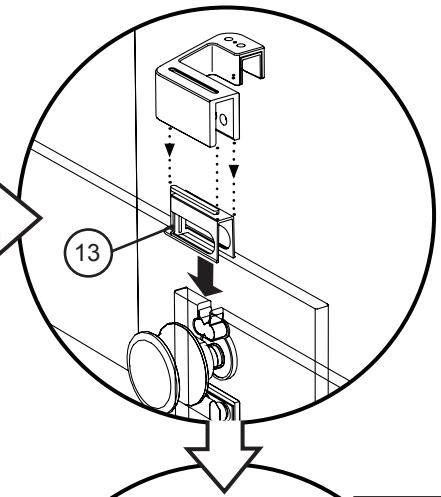
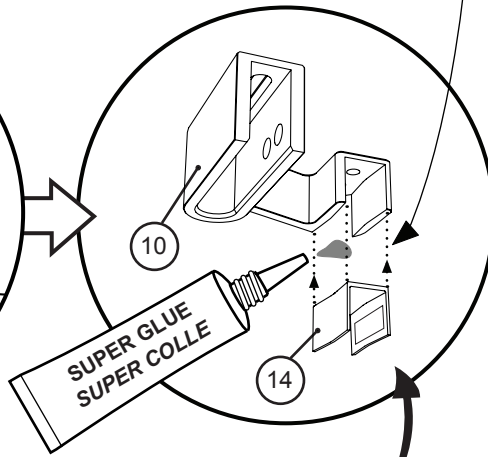
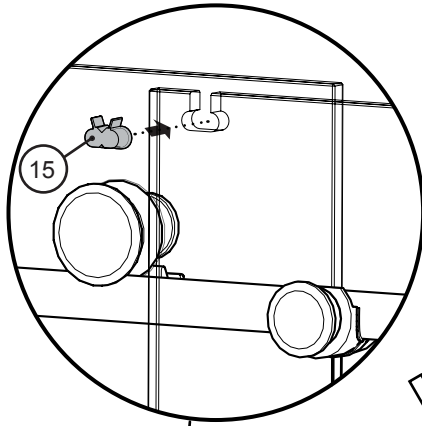

**Use the plastic guide with one dot if the door is on the left. Use the plastic guide with two dots if the door is on the right.**

*Utiliser le guide en plastique avec un point si la porte est située à gauche. Utiliser le guide en plastique avec deux points si la porte est située à droite.*

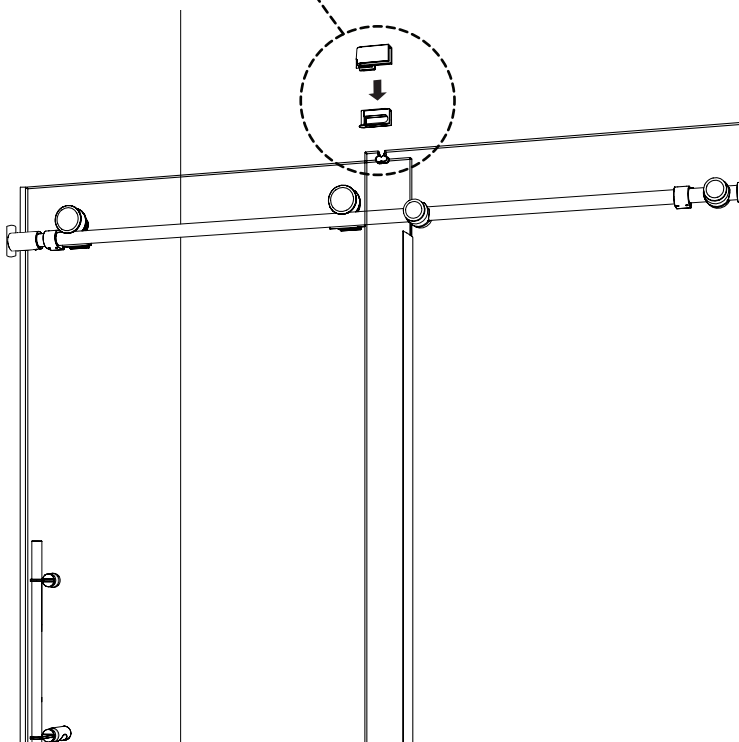
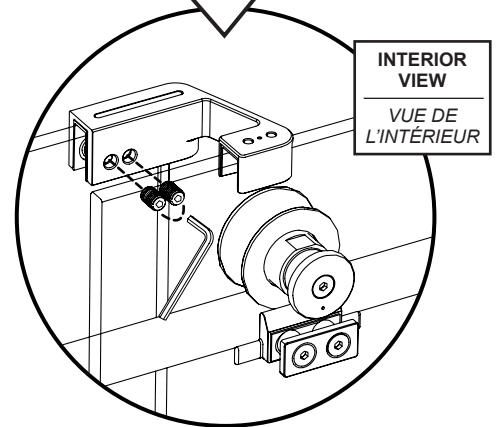

## INSTALL THRESHOLD & THRESHOLD ANCHOR INSTALLER LE SEUIL DE RÉTENTION ET L'ANCRAGE DE SEUIL



TRIM THRESHOLD ON THE WALL  
SIDE IF, NECESSARY, BEFORE  
APPLYING SILICONE.

COUPER LE SEUIL DU CÔTÉ DU  
MUR SI NÉCESSAIRE, AVANT  
D'APPLIQUER LE SILICONE.

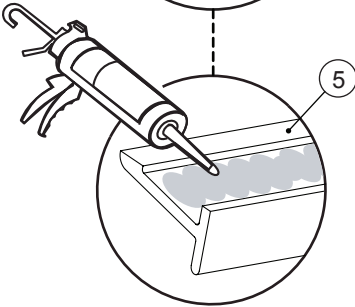
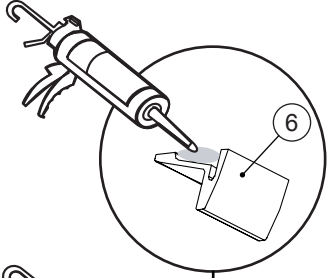
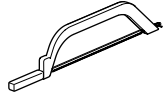

SIDE VIEW  
VUE LATÉRALE

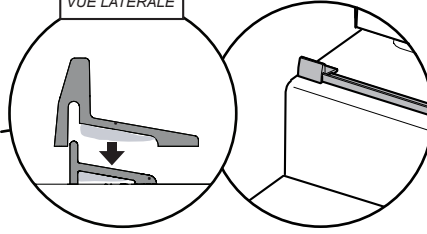

INTERIOR  
SHOWER SIDE  
INTÉRIEUR  
DE LA DOUCHE

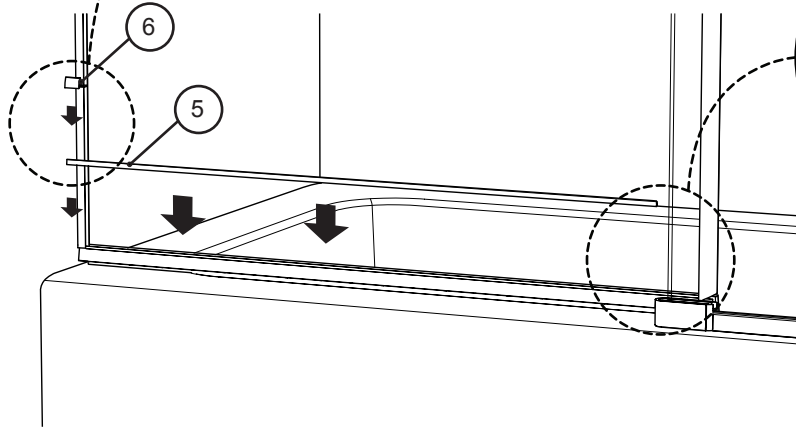
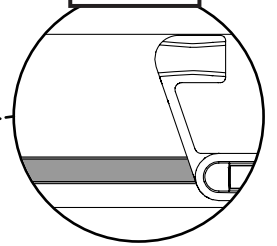

## SEAL THE TUB / CALFEULTRER LA BAIGNOIRE



**24** HOURS  
HEURES

