

**INSTRUCTION MANUAL - GUIDE D'INSTALLATION**

**K013-1**

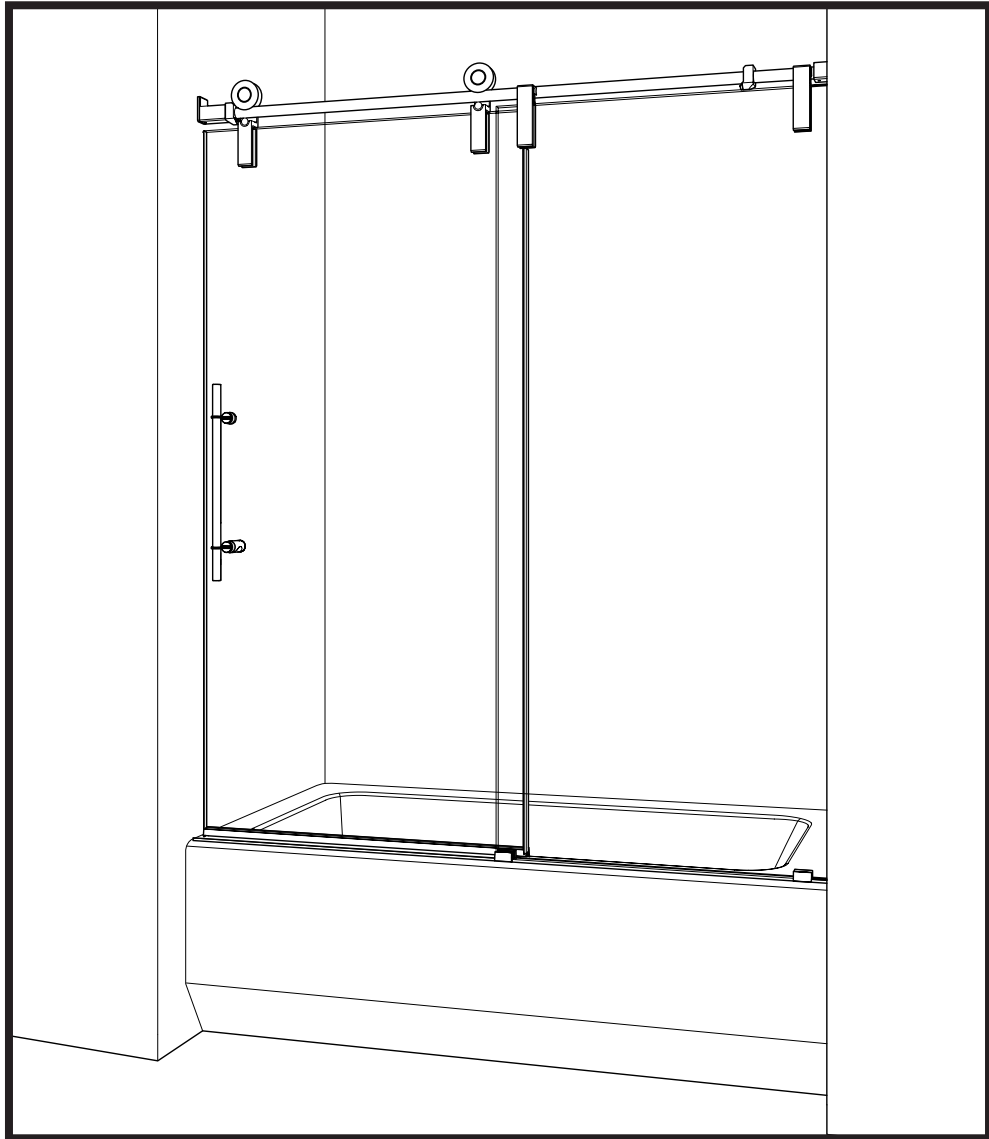

10 / 2013



**2 PEOPLE REQUIRED**  
**2 PERSONNES REQUIS**

Please keep this manual and product code number for future reference  
and for ordering replacement parts if necessary.

*Veuillez conserver ce manuel et le code de produit pour des références futures,  
et au besoin, la commande de pièces de rechange.*

#### GENERAL INSTRUCTIONS

- Read this manual carefully and completely before proceeding.
- It is recommended that you wear safety glasses at all times during the installation.

En

#### INSTALLATION OVER CERAMIC TILES

- If your shower door is to be installed over ceramic tiles, the tiles should lay completely under the wall jamb.
- Silicone should be used to seal the gap where the ceramic tiles meet the fixed panel.

#### NOTICE

- Caulking: no sealant is required inside the shower, unless otherwise stated.
- Some models are equipped with clear sealing gaskets.

#### CARE FOR YOUR SHOWER DOOR

- Never use scouring powder pads or sharp instruments on metal pieces or glass panels. An occasional wiping down with a mild soap diluted in water is all that is needed to keep the panels and aluminum parts looking new.
- We recommend wiping the glass panels with a squeegee after each use.

#### INSTRUCTIONS GÉNÉRALES

- Lire attentivement et complètement le manuel d'installation avant de procéder.
- Il est recommandé de porter des lunettes de sécurité en tout temps lors de l'installation.

Fr

#### INSTALLATION SUR LES TUILES EN CÉRAMIQUE

- Si votre porte de douche doit être installée sur une bordure en céramique, le jambage doit reposer complètement sur cette dernière.
- Le calfeutrage doit être appliqué sur le côté extérieur de la douche où le panneau fixe rencontre la bordure en céramique.

#### NOTE

- Calfeutrage: aucun scellant n'est nécessaire à l'intérieur de la douche.
- Certains modèles sont dotés de joints d'étanchéité clairs.

#### L'ENTRETIEN DE VOTRE DOUCHE

- Ne jamais utiliser de poudre ou de tampon à récurer, ni d'instrument tranchant sur les parties en métal ou en verre. De temps à autre, il suffit de nettoyer la porte avec une solution d'eau et un détergent doux pour conserver l'aspect neuf des panneaux de verre et du cadre en aluminium.
- Nous recommandons de passer une raclette de douche sur les panneaux de verre après chaque utilisation.

## TOOLS REQUIRED / OUTILS REQUIS

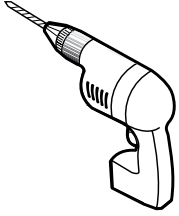

**DRILL**  
PERCEUSE



**1/4" & 1/8" DRILL BITS**  
MÈCHE 1/4" & 1/8"



**SCREWDRIVER**  
TOURNEVIS

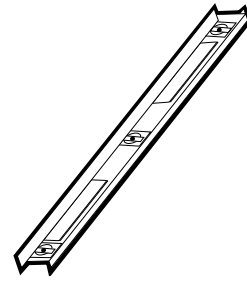

**LEVEL**  
NIVEAU



**PENCIL**  
CRAYON

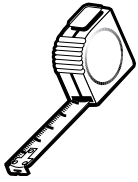

**TAPE MEASURE**  
RUBAN À MESURER

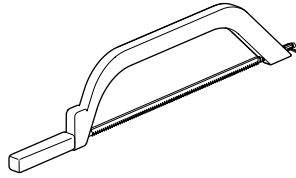

**HACKSAW**  
SCIE À MÉTAUX



**BLOCK**  
BLOC

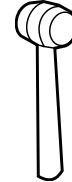

**MALLET**  
MAILLET

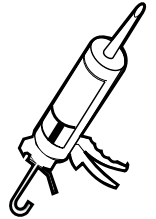

**SILICONE**  
SCCELLANT

\* Use a 1/4" drill bit for ceramic when drilling into ceramic tiles

\* Utiliser une mèche de 1/4" pour céramique pour percer des tuiles en céramique.

## POSSIBLE CONFIGURATIONS / CONFIGURATIONS POSSIBLES

\*

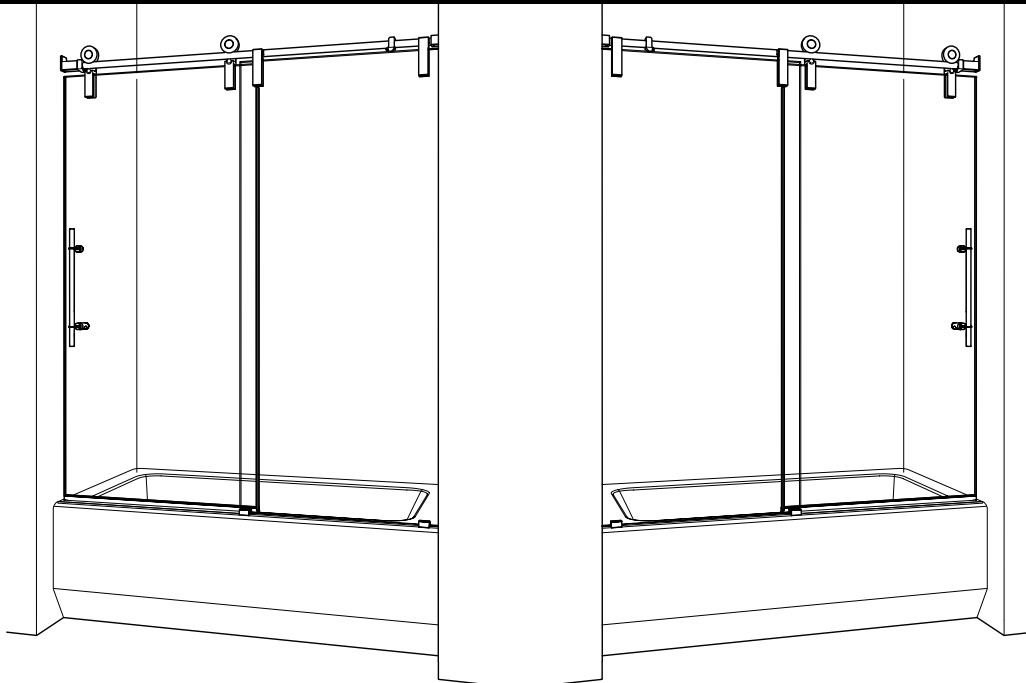

\* This configuration illustrated in this manual.

\* Cette configuration est illustrée dans ce manuel.



IT IS HIGHLY ADVISED TO SECURE THE WALL BRACKETS INTO WALL STUDS ON EACH SIDE.

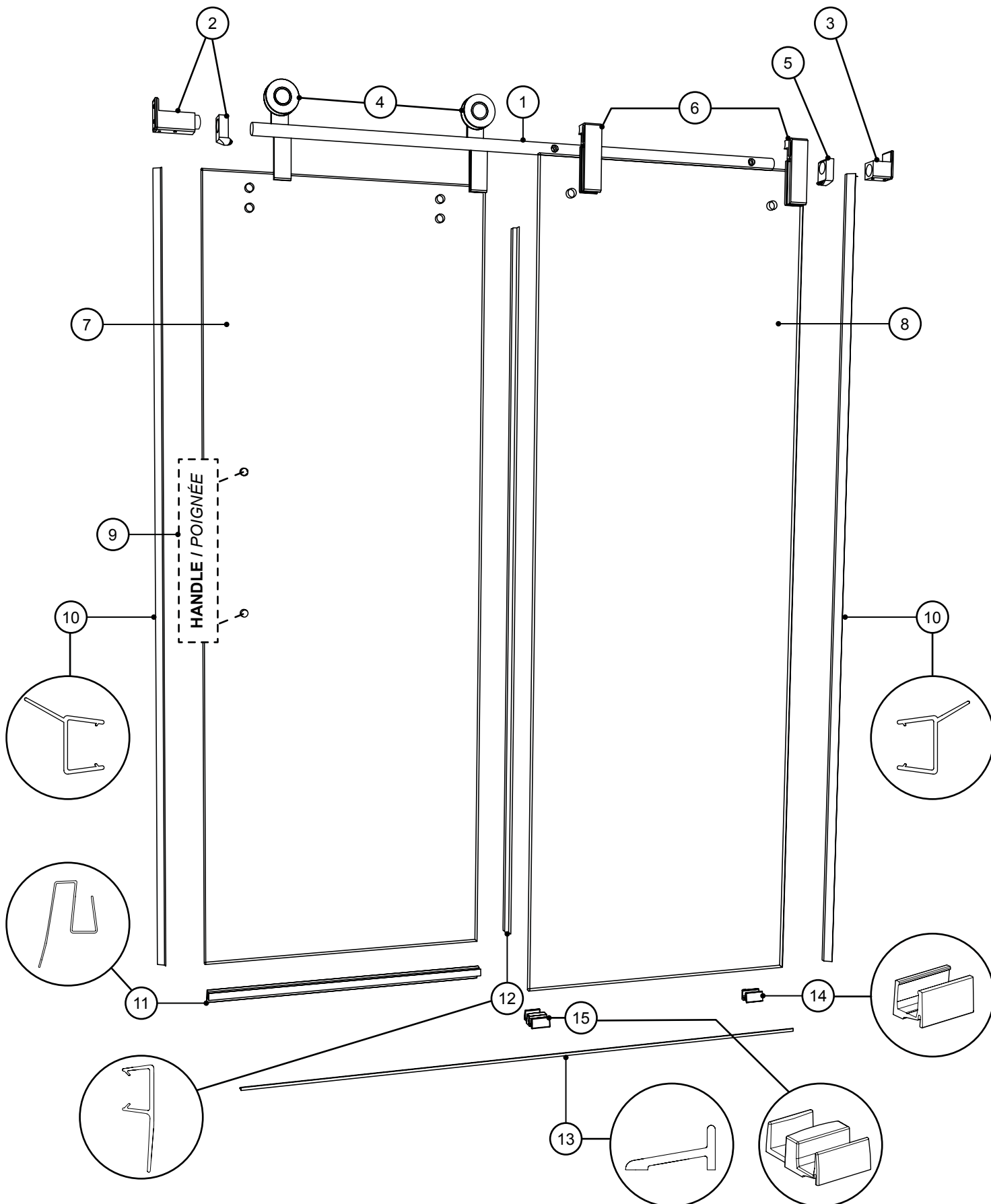

IL EST FORTEMENT RECOMMANDÉ DE SÉCURISER LES SUPPORTS MURAUX DANS DES MONTANTS MURAUX SUR CHAQUE CÔTÉ DU MUR.

PARTS LISTING / LISTE DES PIÈCES



**PARTS LISTING / LISTE DES PIÈCES**

9

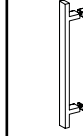
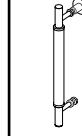
<b>HANDLE OPTIONS / SÉLECTION DES POIGNÉES</b>				
<b>A</b>	<b>B</b>	<b>C</b>	<b>D</b>	<b>E</b>
				

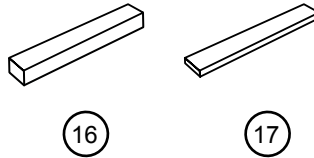

<b>ITEM</b>	<b>PARTS AND HARDWARE / PIÈCES ET QUINCAILLERIE</b>	<b>QTY</b>
1	RUNNING RAIL / BARRE DE ROULEMENT	1
2	DOOR WALL BRACKET WITH BUILT-IN STOPPER / SUPPORT MURAL DE LA PORTE AVEC BUTOIR INTÉGRÉ	1
3	FIXED PANEL WALL BRACKET / SUPPORT MURAL DU PANNEAU FIXE	1
4	ROLLER / ROULETTE	2
5	STOPPER / BUTOIR	1
6	GLASS FASTENER / FIXATION DE VERRE	2
7	DOOR PANEL / PANNEAU DE PORTE	1
8	FIXED PANEL / PANNEAU FIXE	1
9	HANDLE ( see chart above ) / POIGNÉE ( voir le tableau ci-dessus )	1
10	WALL SIDE GASKET / JOINT DU CÔTÉ DU MUR	2
11	BOTTOM DOOR GASKET / JOINT INFÉRIEUR DE LA PORTE	1
12	DOOR SIDE GASKET / JOINT LATÉRAL DE LA PORTE	1
13	THRESHOLD / SEUIL	1
14	BOTTOM GLASS CLIP / SUPPORT DE VERRE INFÉRIEUR	1
15	BOTTOM GUIDE / GUIDE INFÉRIEUR	1
16	CLEAR SETTING BLOCK (1/8") / BLOC NIVEAU TRANSPARENT (1/8")	4
17	CLEAR SETTING BLOCK (1/32") / BLOC NIVEAU TRANSPARENT (1/32")	4

1

**PLACE THE BOTTOM GUIDE, THE BOTTOM CLIP AND THE THRESHOLD ONTO THE BASE**  
*PLACER LE GUIDE INFÉRIEUR, LE SUPPORT INFÉRIEUR ET LE SEUIL SUR LA BASE*

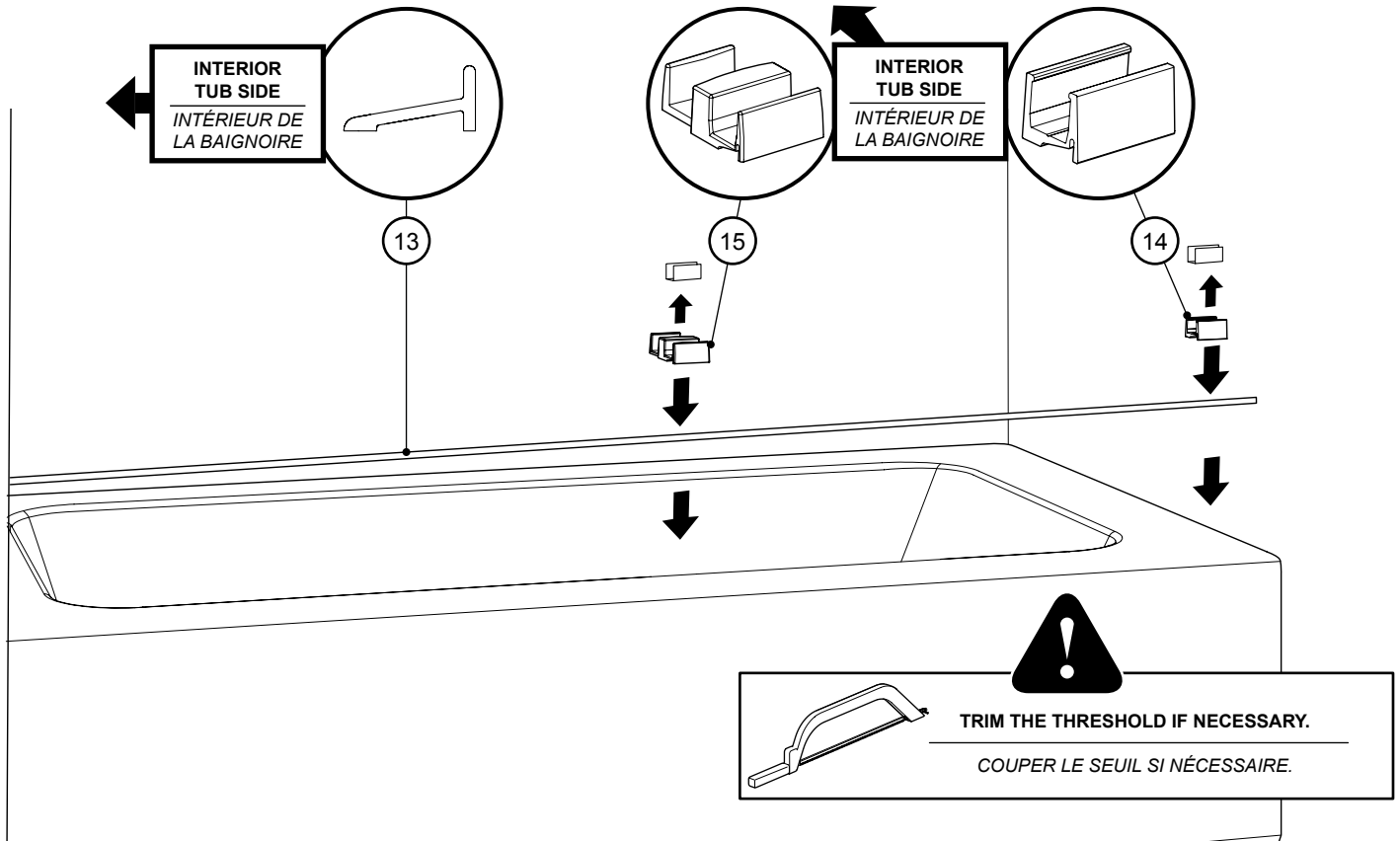

2

**PLACE THE BOTTOM GUIDE AND BOTTOM GLASS CLIP AS SHOWN**  
*PLACER LE GUIDE INFÉRIEUR ET LE SUPPORT DE VERRE INFÉRIEUR TEL QU'ILLUSTRÉ*

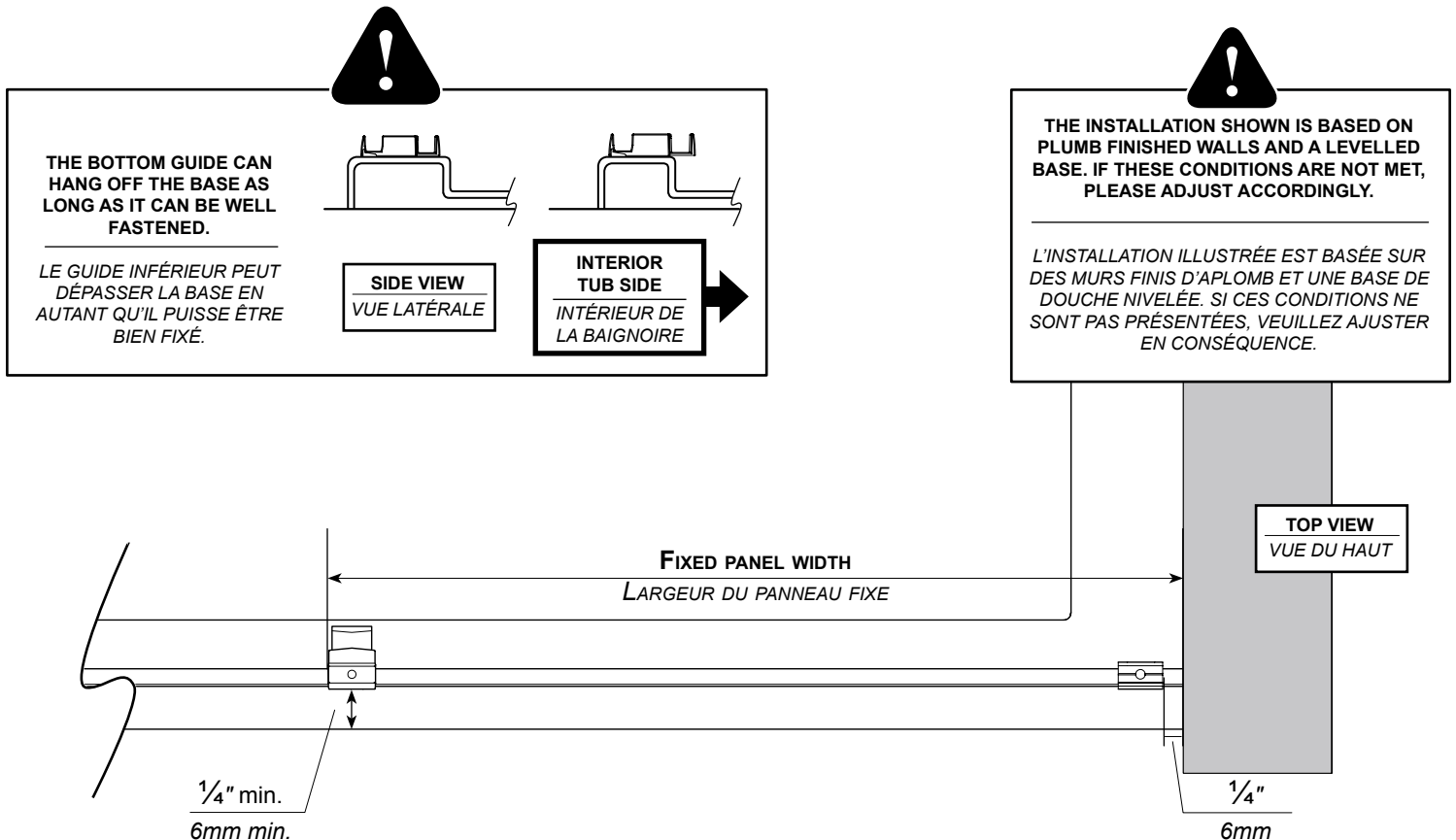

3

**MARK THE LOCATION OF THE BOTTOM GUIDE, BOTTOM GLASS CLIP AND THE THRESHOLD**  
*MARQUER LA POSITION DU GUIDE INFÉRIEUR, LE SUPPORT DE VERRE INFÉRIEUR ET LE SEUIL*

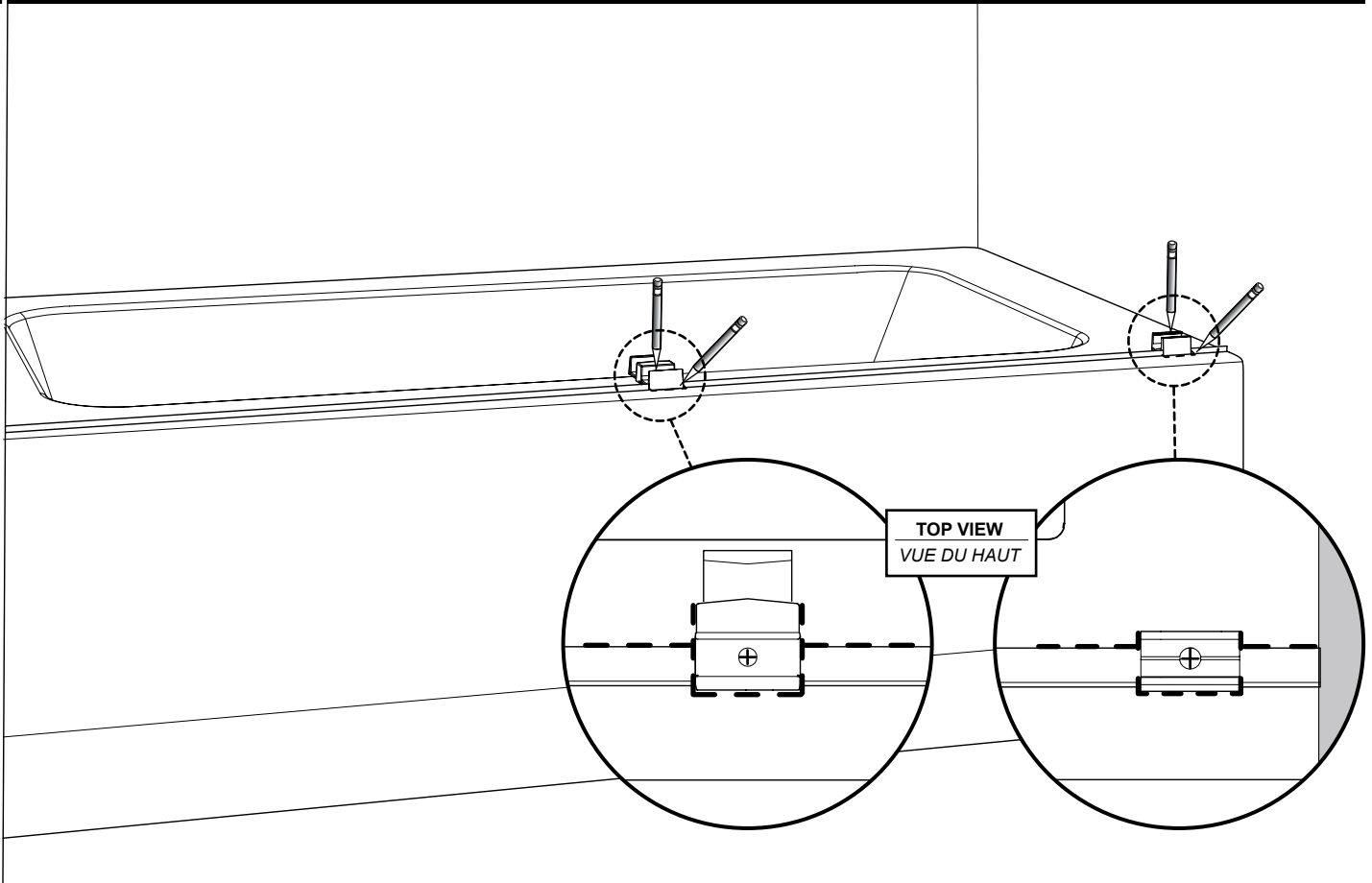

4

**REMOVE THE BOTTOM GUIDE, THE BOTTOM GLASS CLIP AND THE THRESHOLD**  
*ENLEVER LE GUIDE INFÉRIEUR, LE SUPPORT DE VERRE INFÉRIEUR ET LE SEUIL*

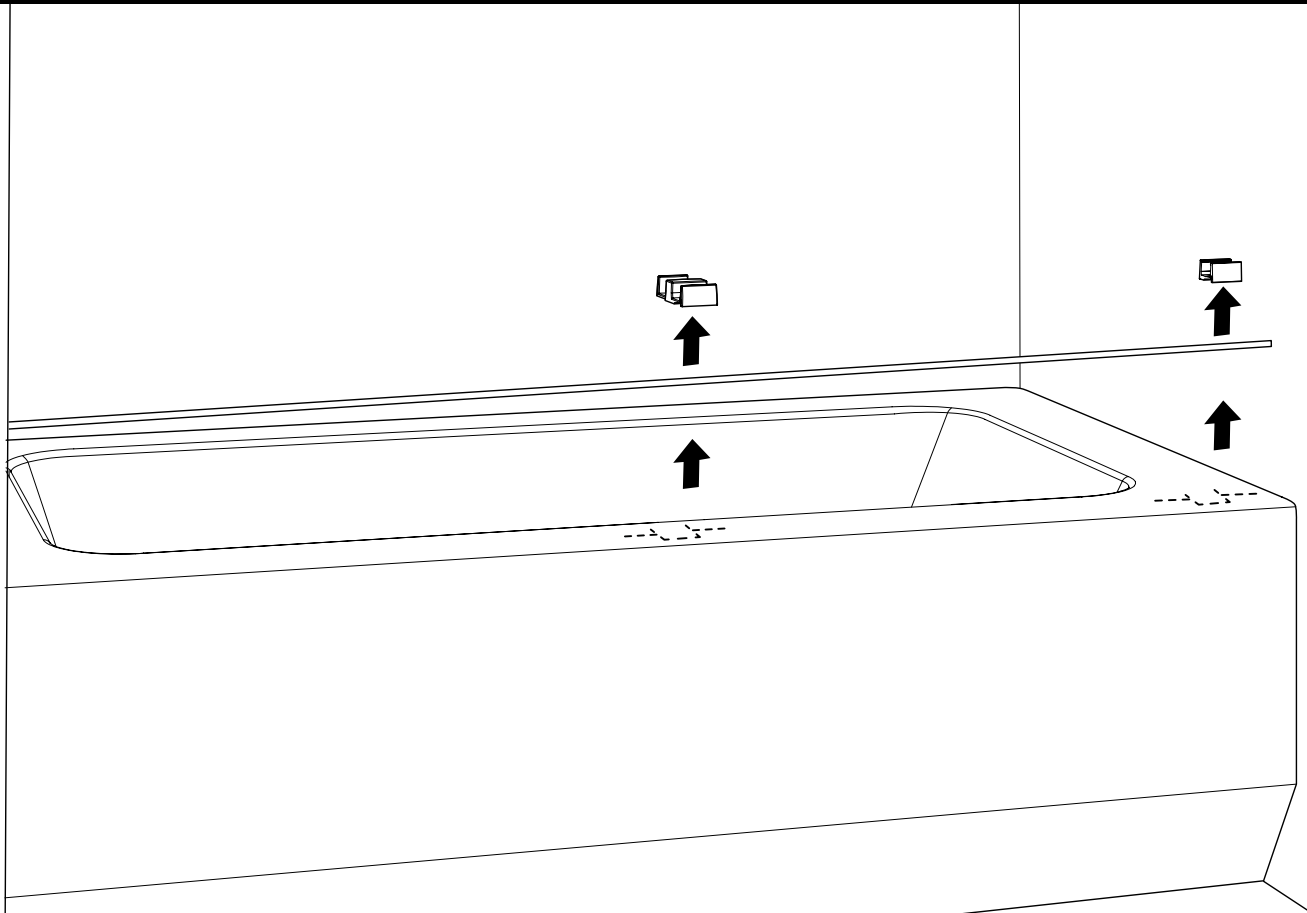

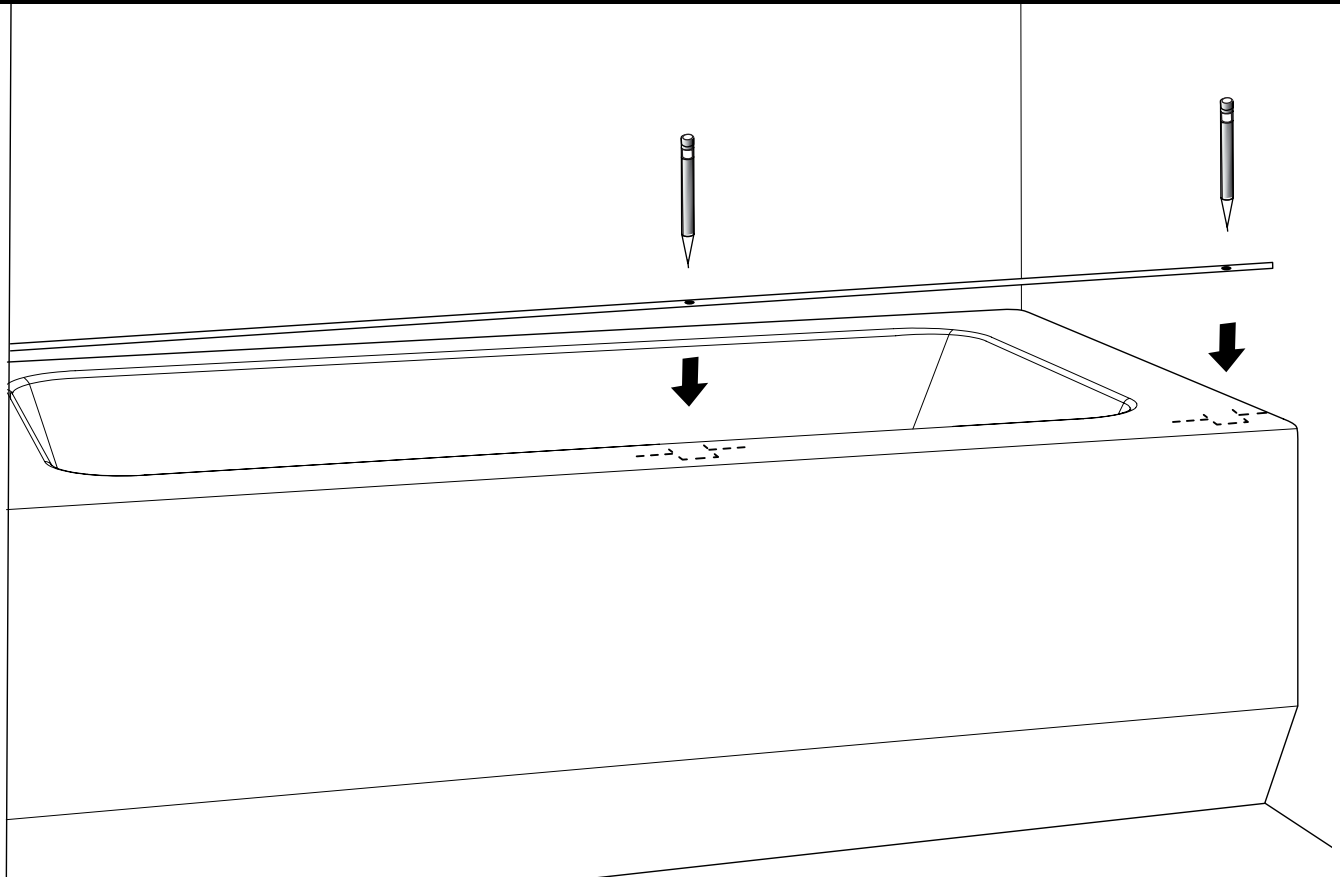
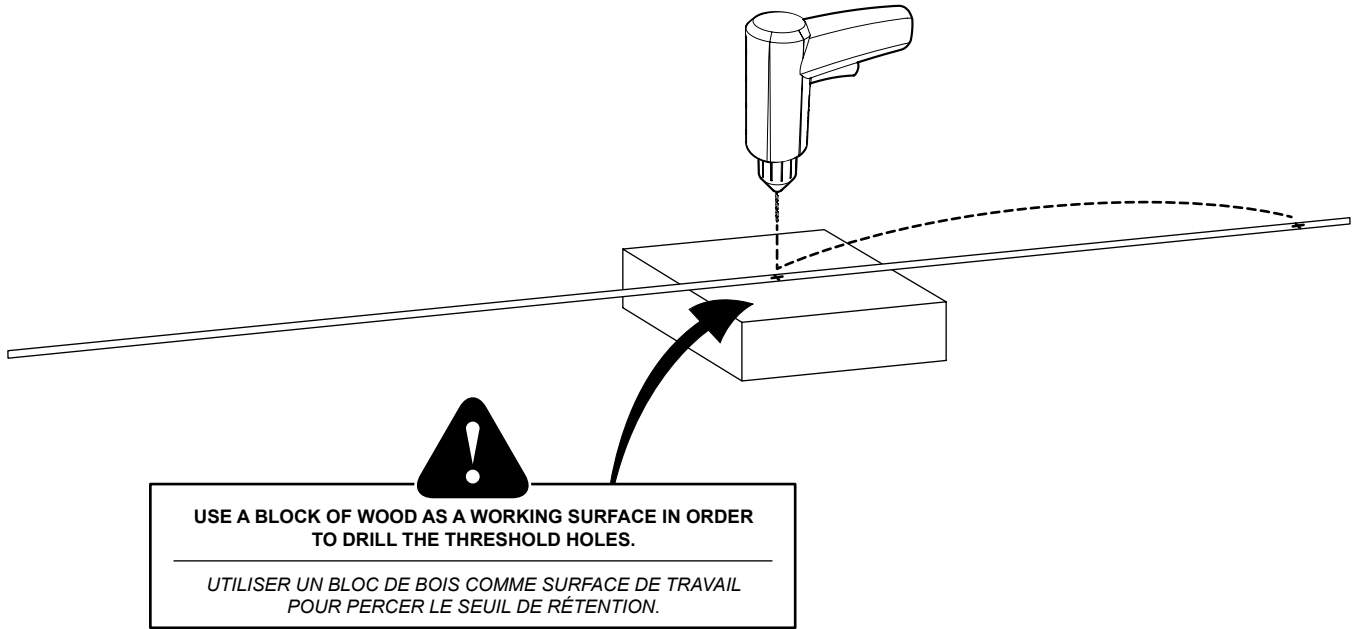



7

REMOVE THE THRESHOLD / ENLEVER LE SEUIL

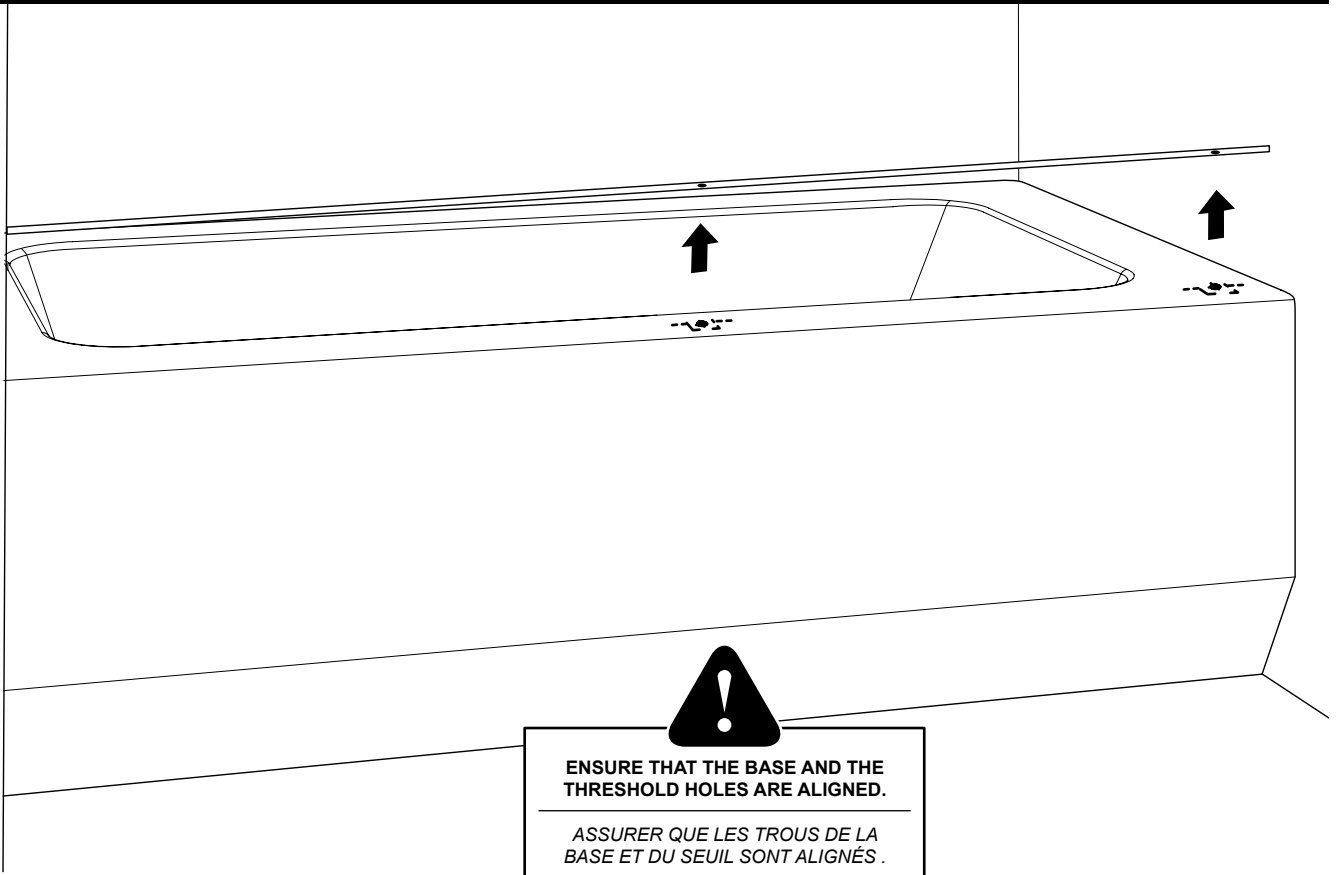

8

DRILL AND SILICONE THE BASE / PERCER ET SCELLER LA BASE

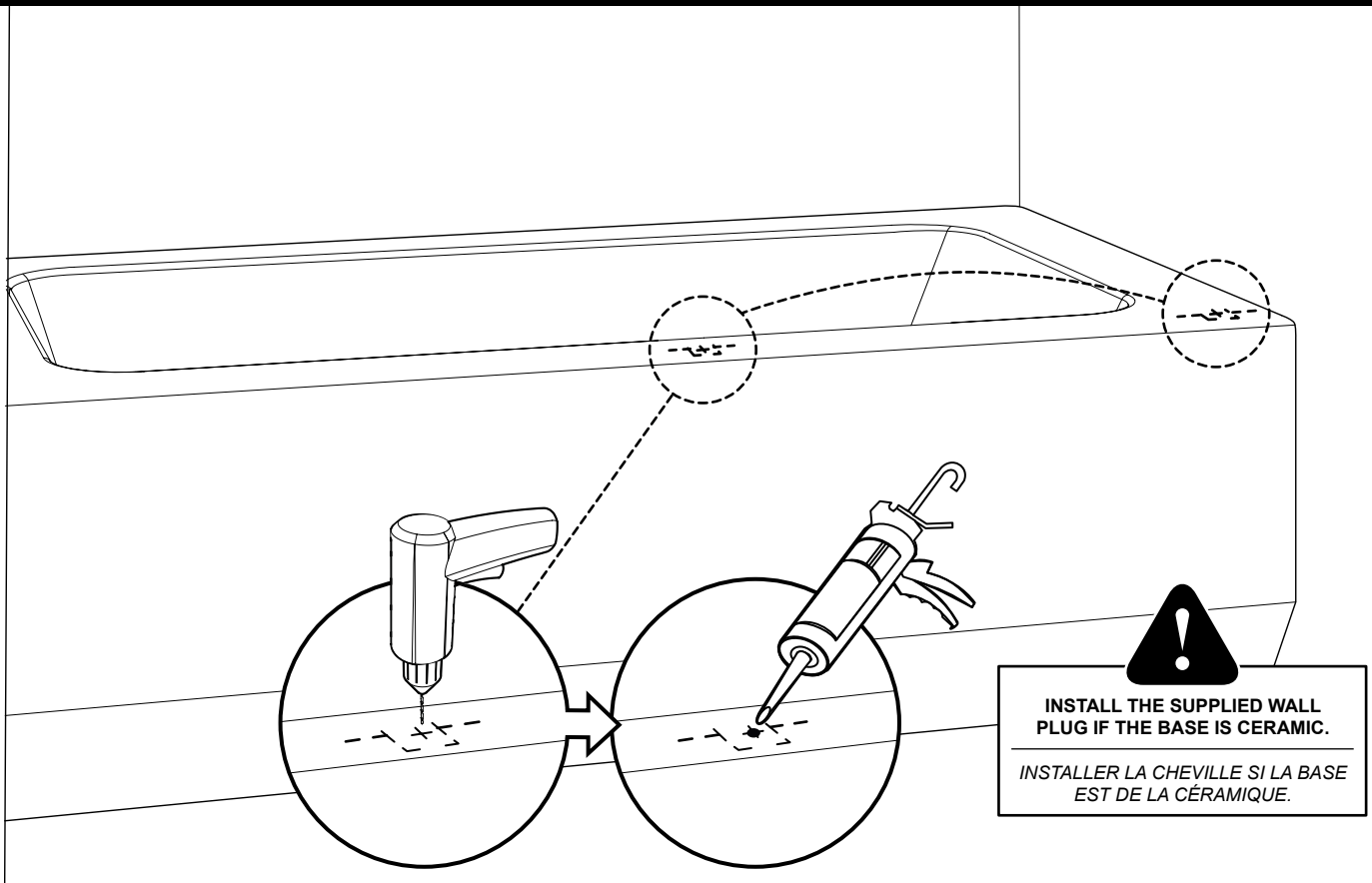

9

**INSTALL THE BOTTOM GUIDE AND THE BOTTOM CLIP**  
**INSTALLER LE GUIDE INFÉRIEUR ET LE SUPPORT INFÉRIEUR**

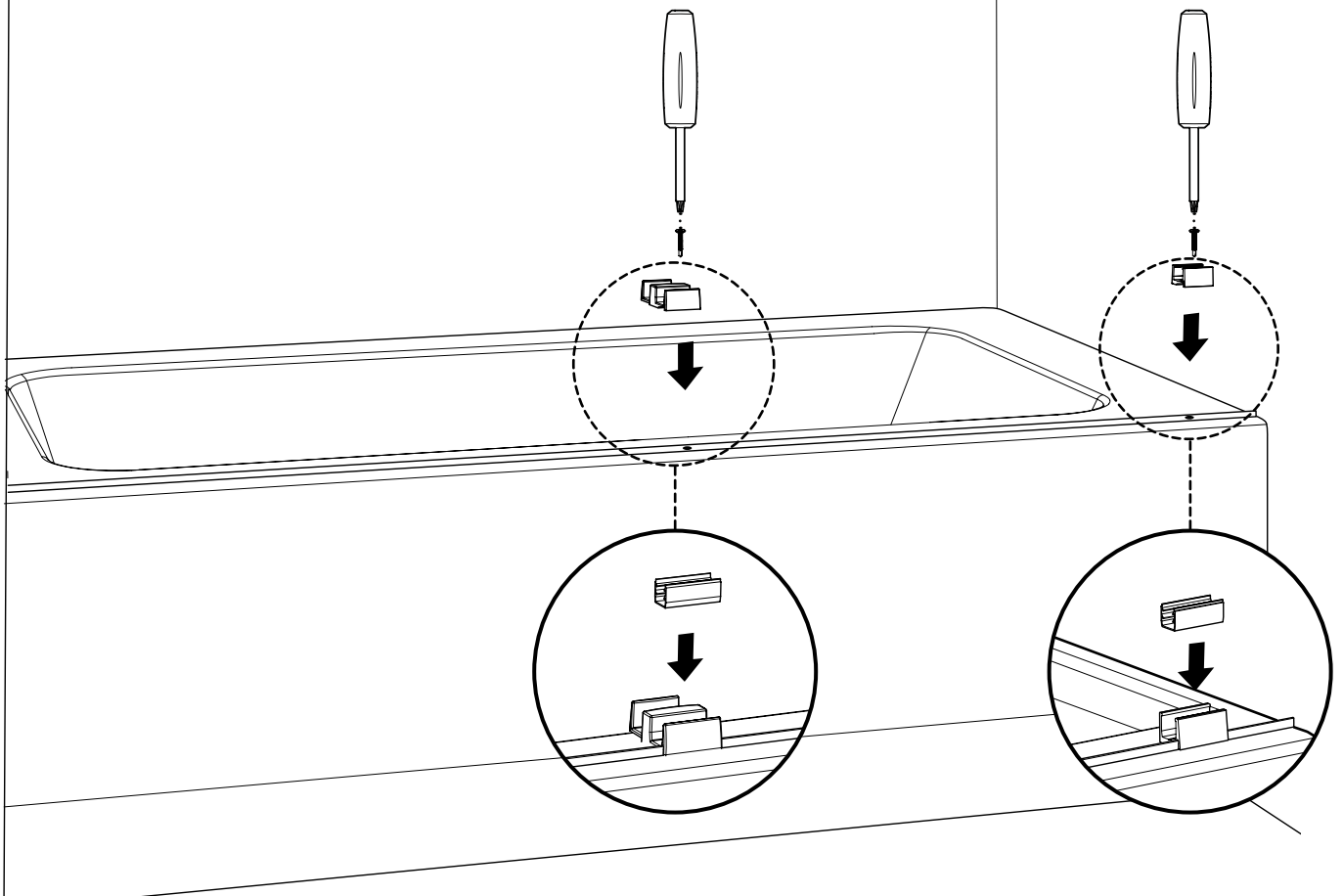

10

**ASSEMBLE THE RUNNING RAIL / ASSEMBLER LA BARRE DE ROULEMENT**

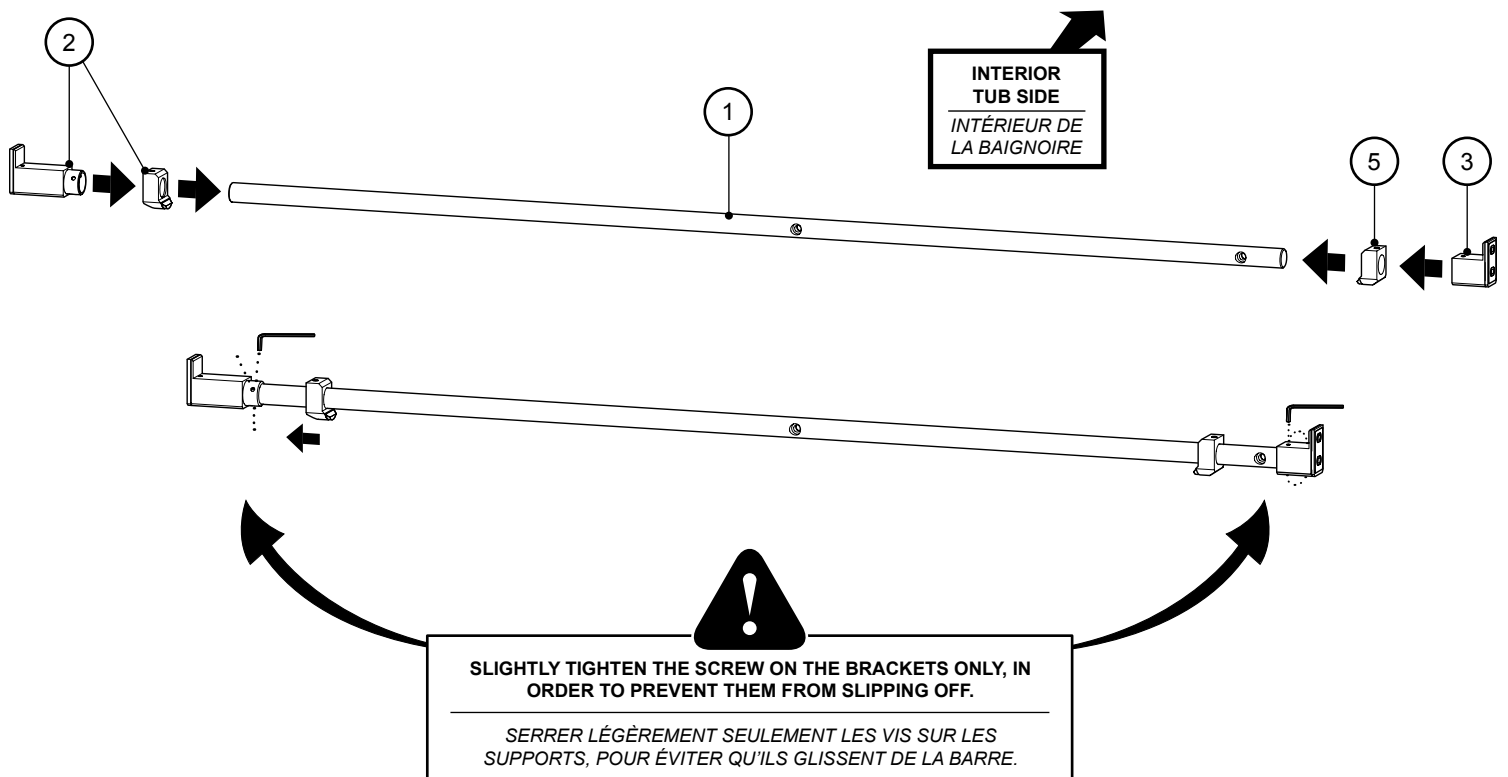

**11** **INSTALL FIXED PANEL GASKET / INSTALLER LE JOINT SUR LE PANNEAU FIXE**

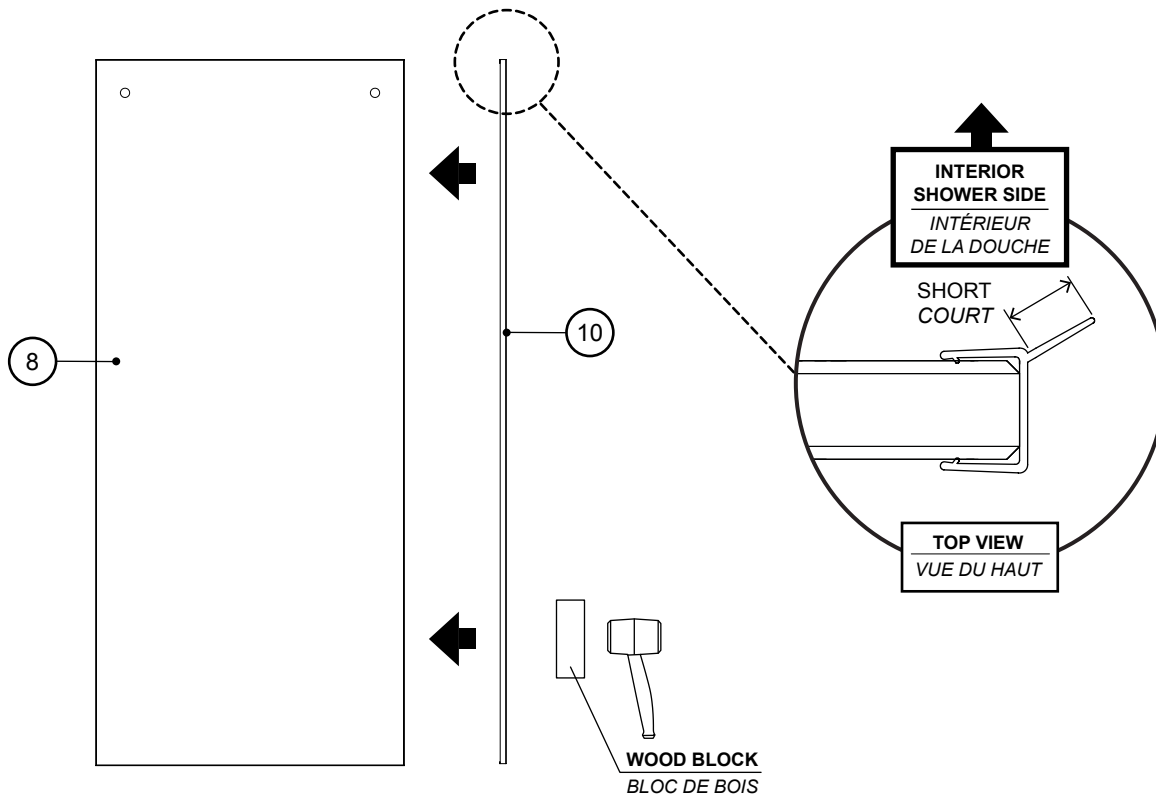

**12** **INSTALL GLASS FASTENERS / INSTALLER LES FIXATIONS DE VERRE**

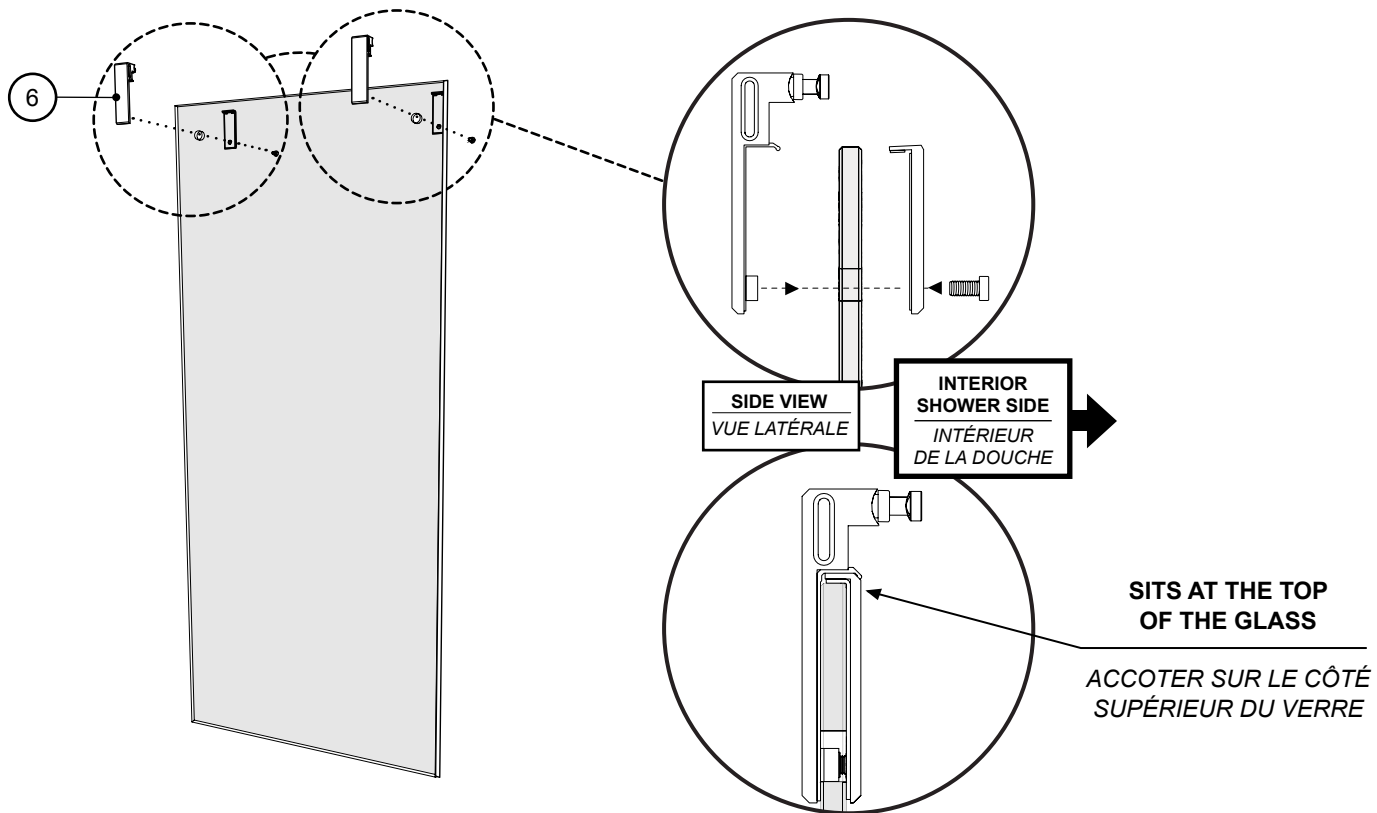

13

INSERT FIXED PANEL INTO GUIDE & CLIP / INSÉRER LE PANNEAU FIXE DANS LE GUIDE ET LE SUPPORT DE VERRE

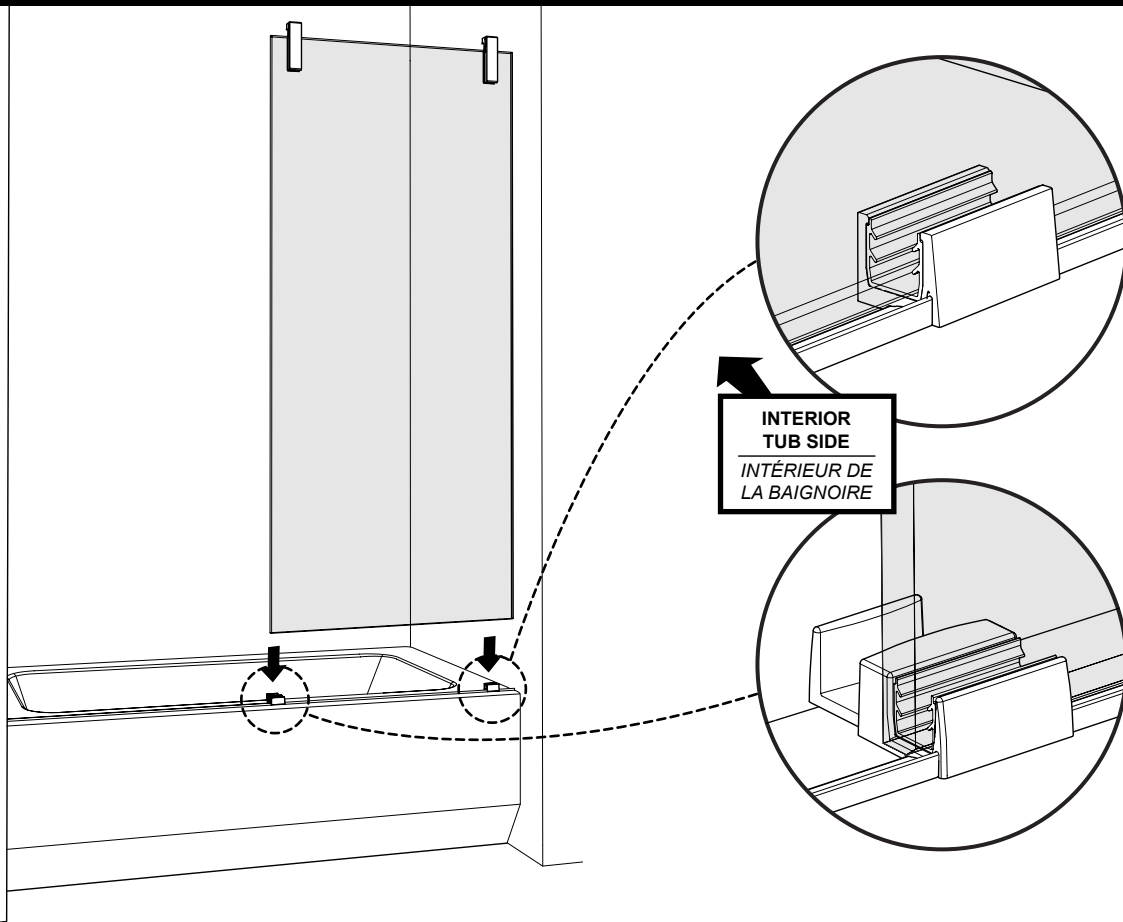

14

SECURE RUNNING RAIL ONTO GLASS FASTENERS TEMPORARILY / SÉCURISER LA BARRE DE ROULEMENT SUR LES SUPPORTS DE VERRE TEMPORAIREMENT

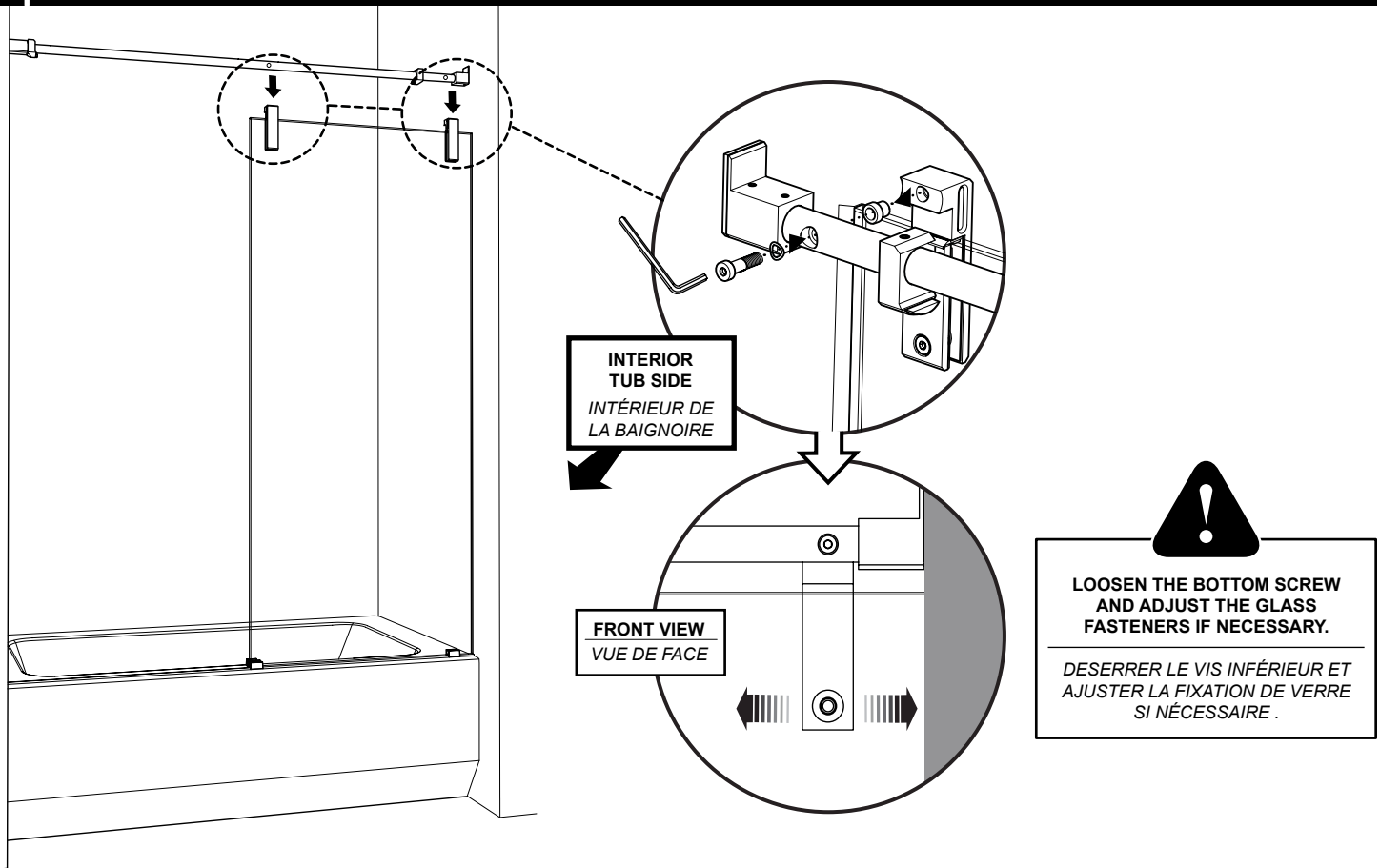

15

**ENSURE THAT THE FIXED PANEL IS PUSHED AGAINST THE WALL AND FLUSH WITH THE WALL**  
**ASSURER QUE LE PANNEAU FIXE EST POUSSÉ CONTRE LE MUR ET D'APLOMB AVEC LE MUR**

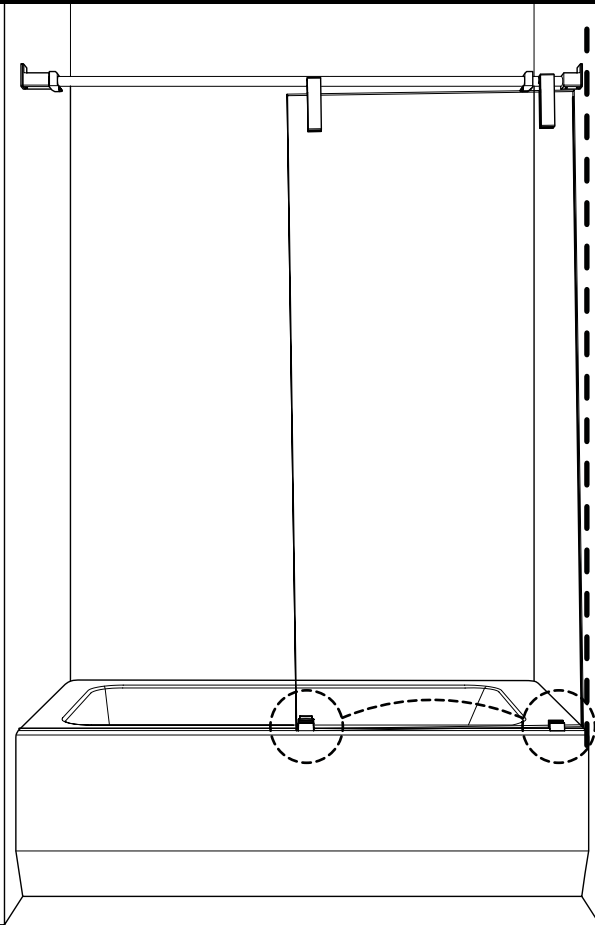

**ADD CLEAR SETTING BLOCKS INTO THE BOTTOM GUIDE OR BOTTOM CLIP IF NECESSARY.**

*AJOUTER DES BLOCS À NIVEAU AU GUIDE OU AU SUPPORT DE VERRE SI NÉCESSAIRE.*

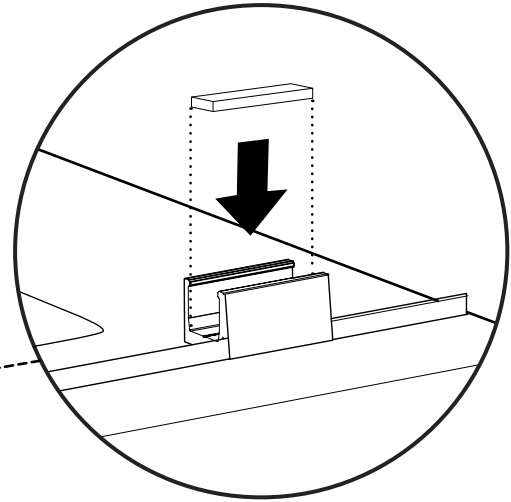

16

**LEVEL THE RUNNING RAIL AND ADJUST IF NECESSARY**  
**NIVELER LA BARRE DE ROULEMENT ET AJUSTER SI NÉCESSAIRE**

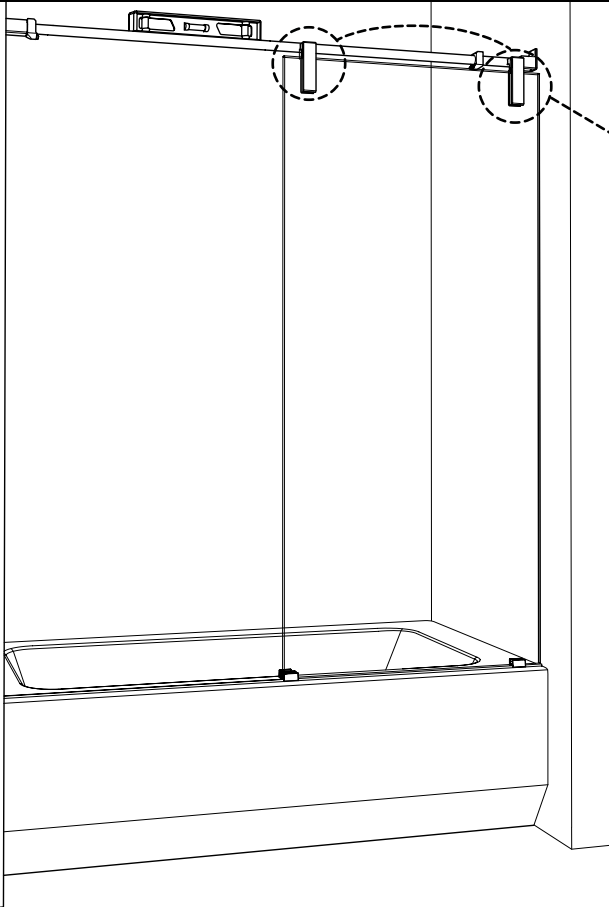

**FRONT VIEW**  
*VUE DE FACE*

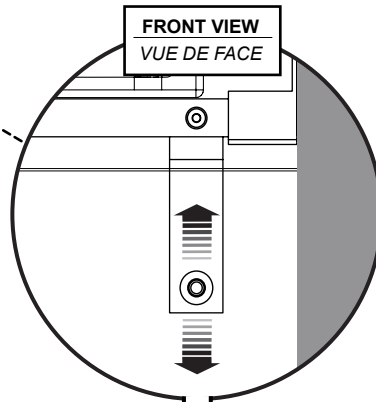

**LOOSEN THE BOTTOM SCREW AND ADJUST THE GLASS FASTENERS IF NECESSARY.**

*DESERRER LE VIS INFÉRIEUR ET AJUSTER LA FIXATION DE VERRE SI NÉCESSAIRE.*

**SIDE VIEW**  
*VUE LATÉRALE*

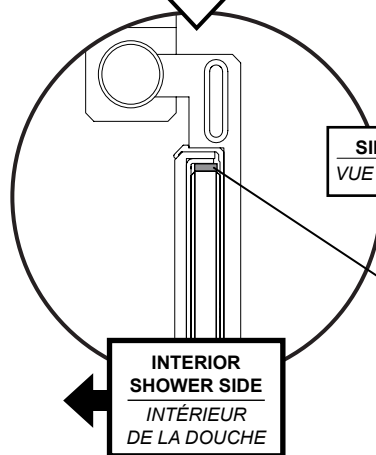

**CLEAR SETTING BLOCK**  
*BLOC À NIVEAU TRANSPARENT*

**INTERIOR SHOWER SIDE**  
*INTÉRIEUR DE LA DOUCHE*

17

**LEVEL THE FIXED PANEL AND MARK THE WALL BRACKETS**  
**NIVELER LE PANNEAU FIXE ET MARQUER LES SUPPORTS MURAUX**

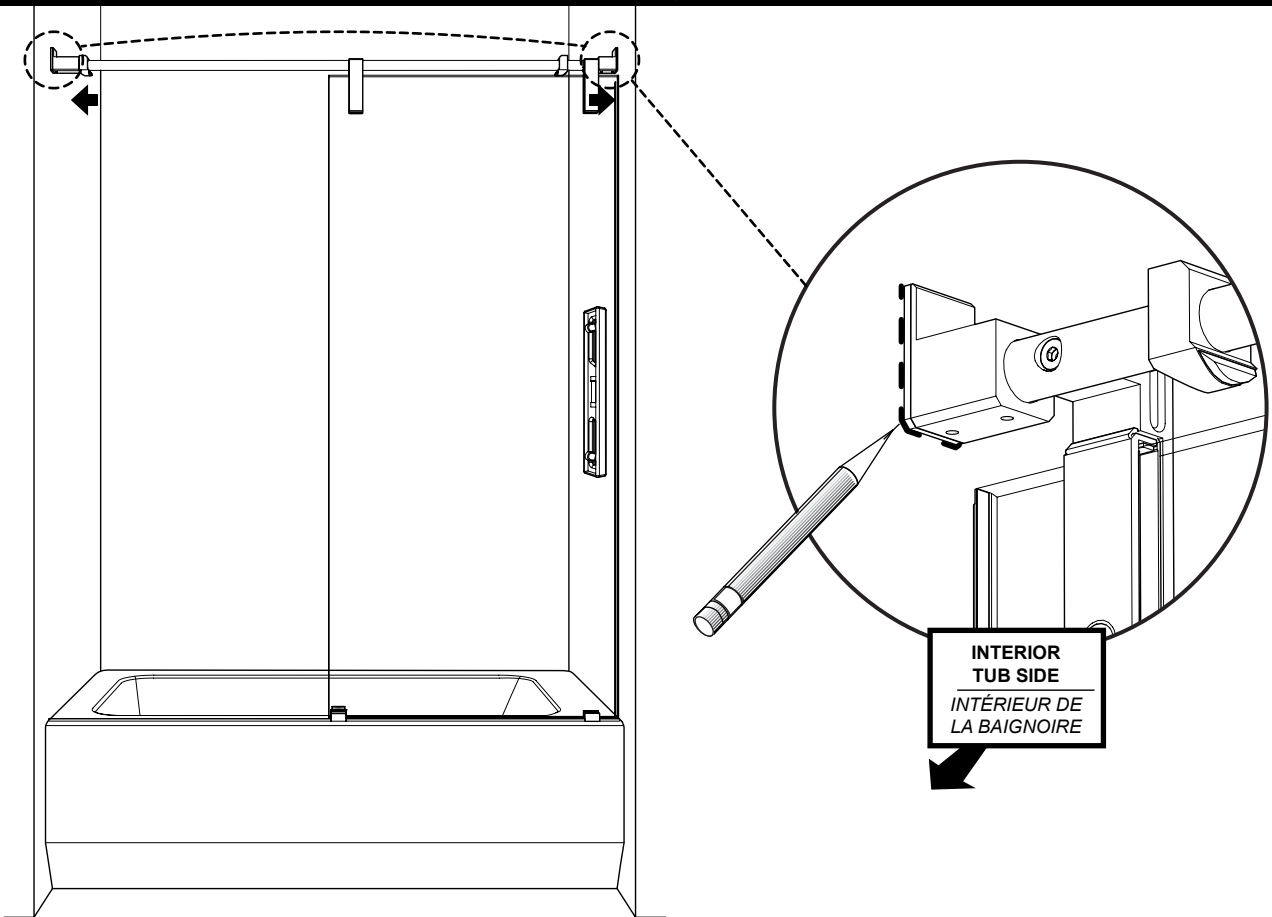

18

**REMOVE THE RUNNING RAIL / ENLEVER LA BARRE DE ROULEMENT**

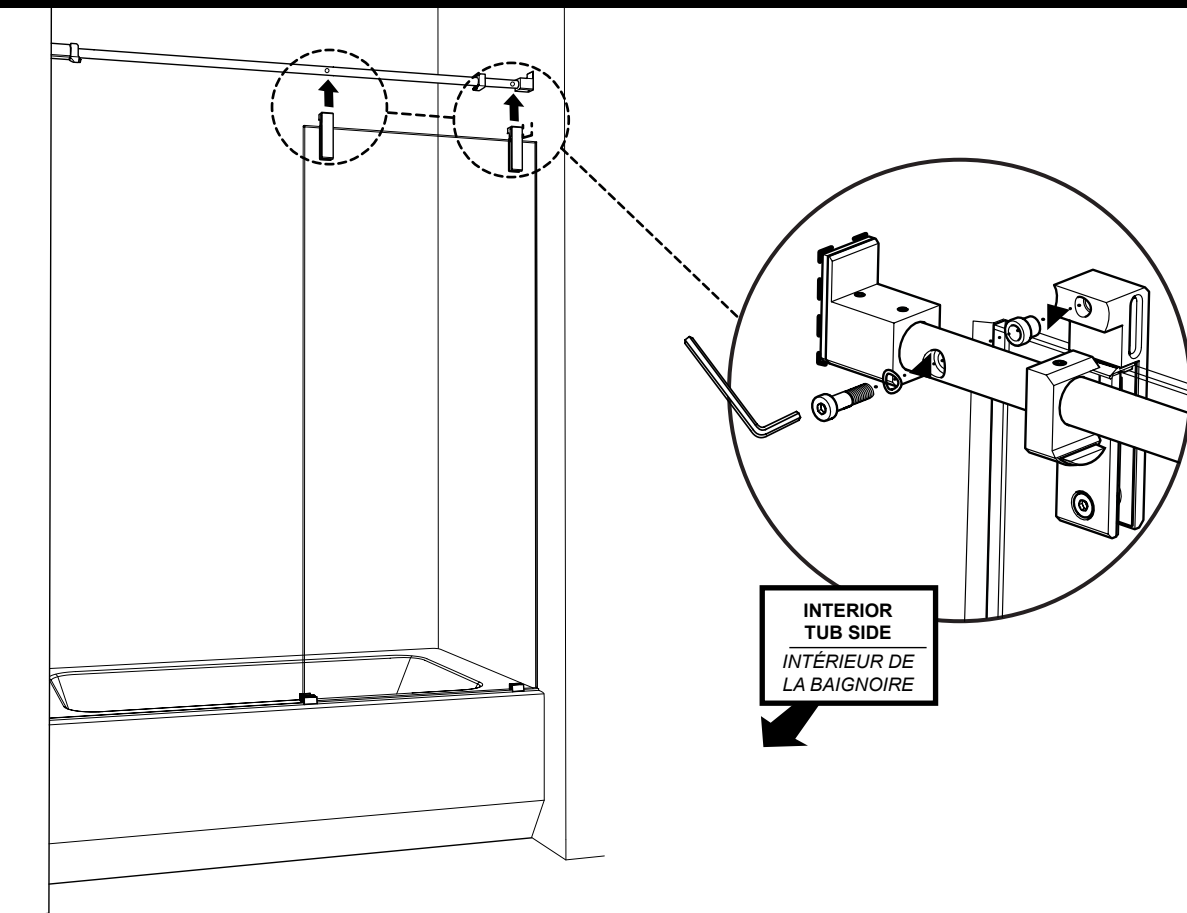

19

REMOVE THE FIXED PANEL / ENLEVER LE PANNEAU FIXE

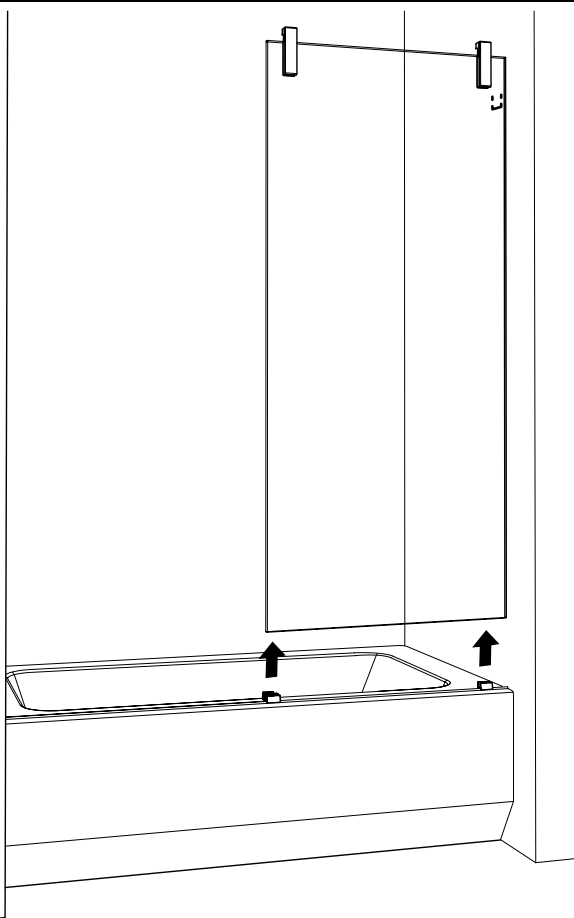

PLACE THE FIXED PANEL ON  
CARDBOARD OR A TOWEL.

PLACER LE PANNEAU FIXE SUR UNE  
SERVIETTE OU DU CARTON.

20

INSTALL THE BOTTOM GASKET ONTO THE DOOR / INSTALLER LE JOINT INFÉRIEUR SUR LA PORTE

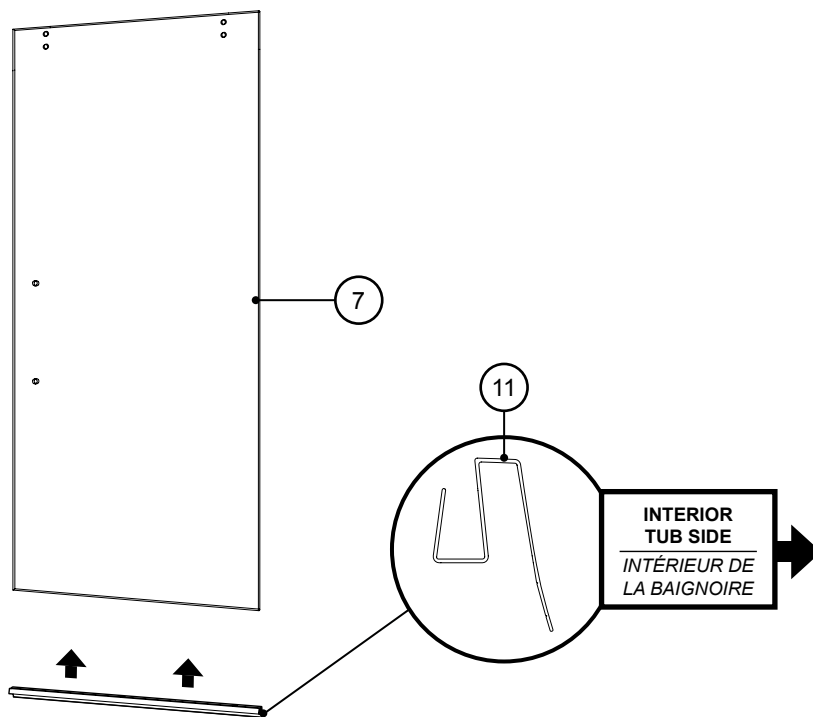

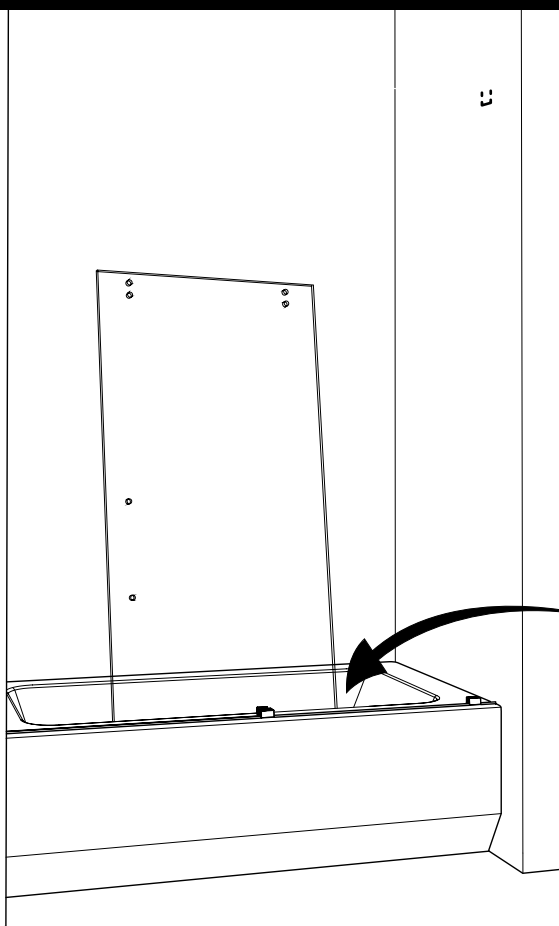

PLACE THE DOOR ON A TOWEL TO PREVENT SCRATCHING THE TUB BASE. ENSURE THAT IT IS FACING THE RIGHT DIRECTION.

PLACER LA PORTE SUR UNE SERVIETTE POUR ÉVITER DE RAYER LA BASE DE LA BAIGNOIRE. ASSURER QU'ELLE EST BIEN ORIENTÉE.

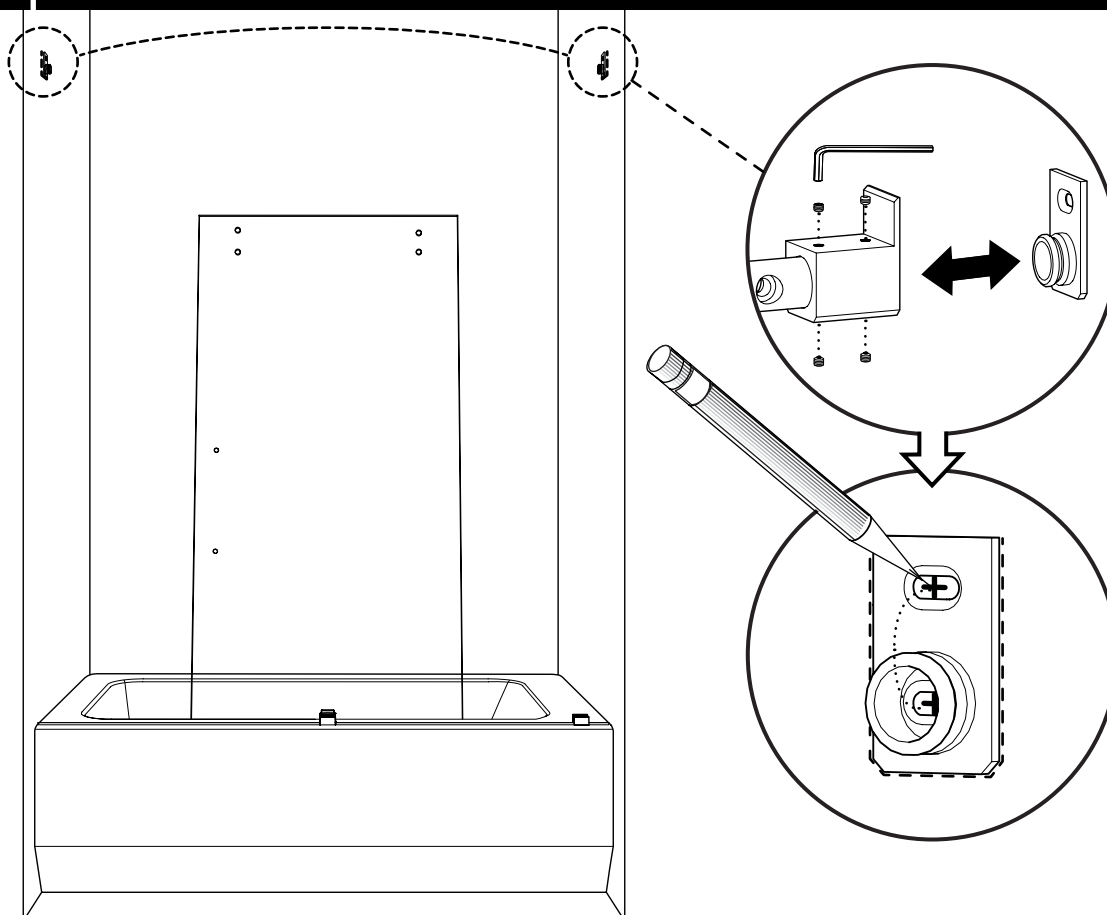

SLIGHTLY LOOSEN THE WALL BRACKET SCREWS.

LÉGÈREMENT DESSERER LES VIS DU SUPPORT MURAL.



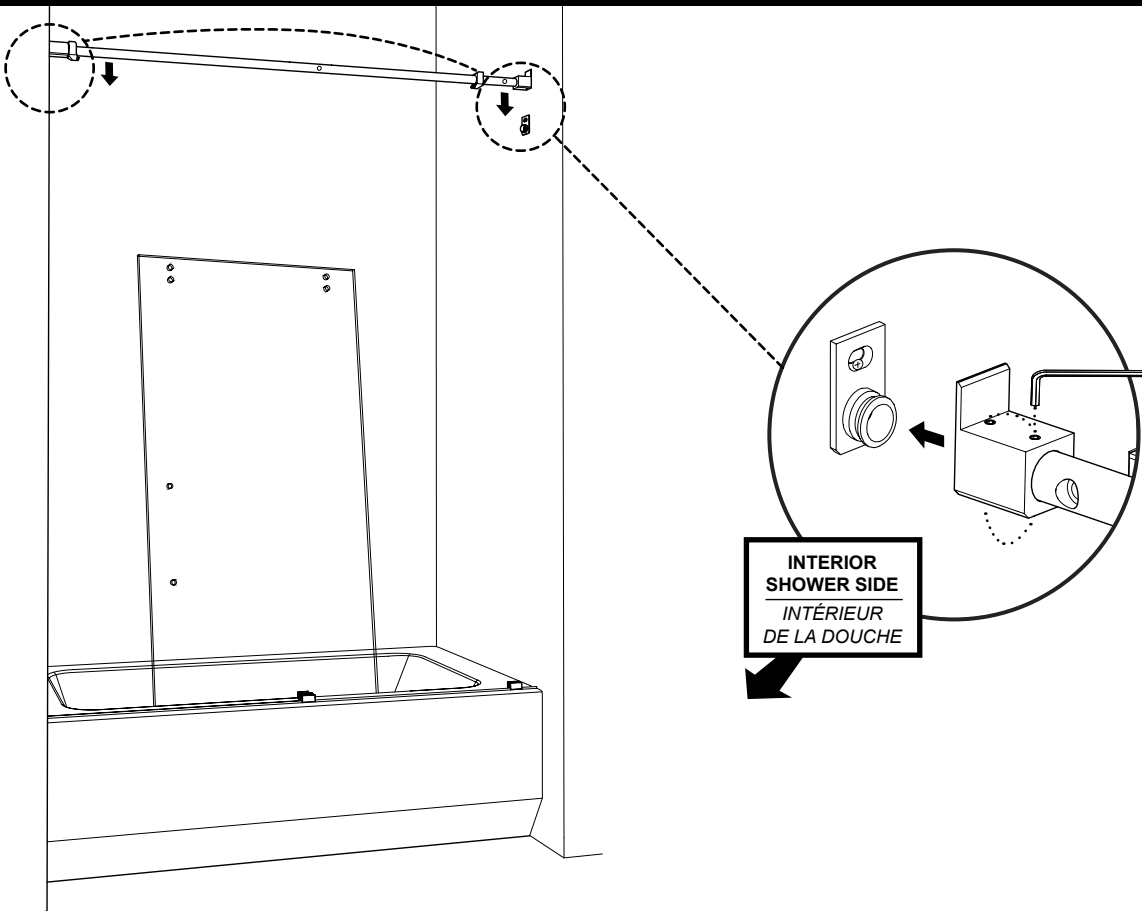
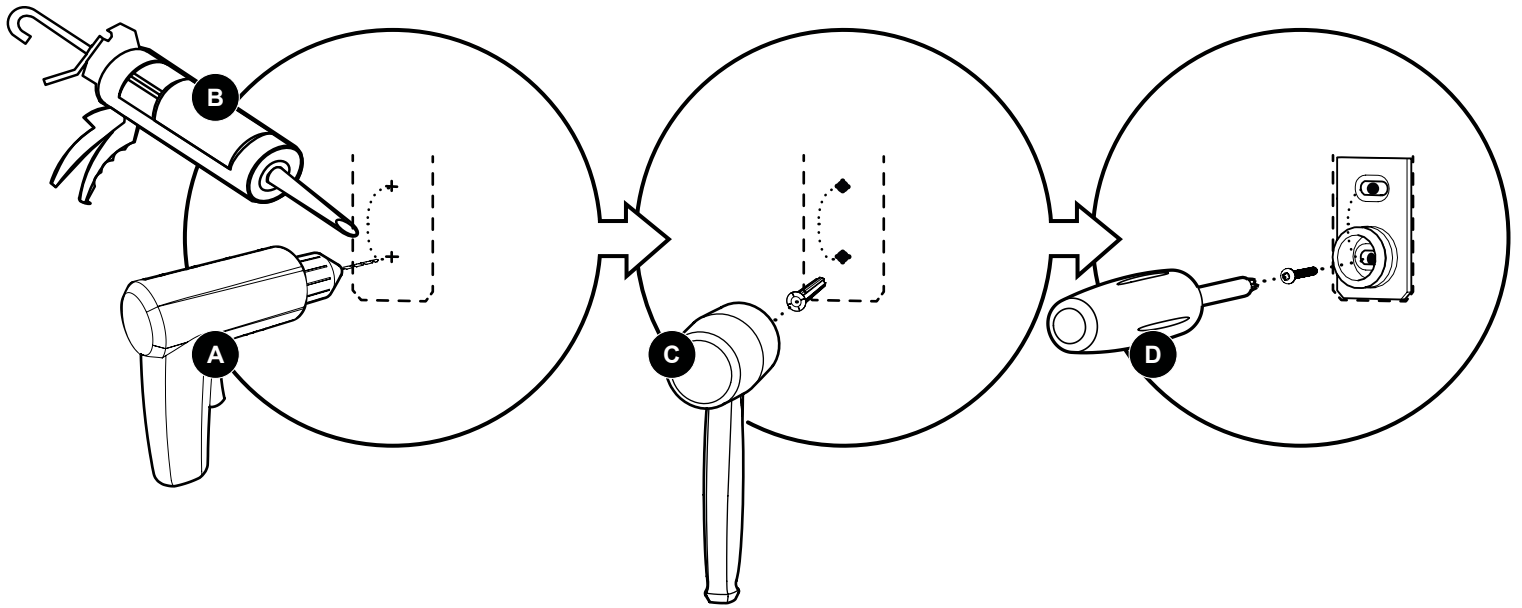

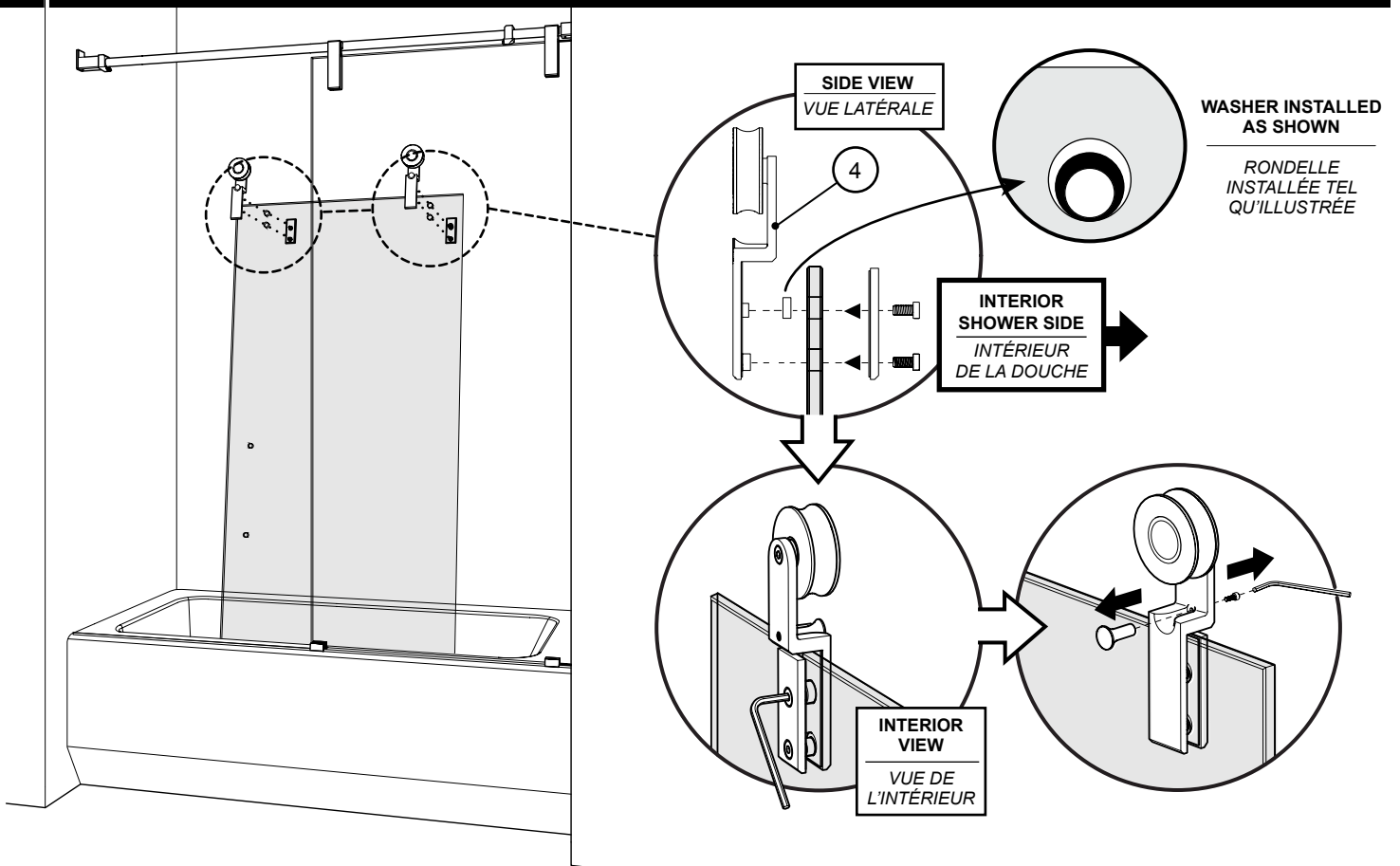
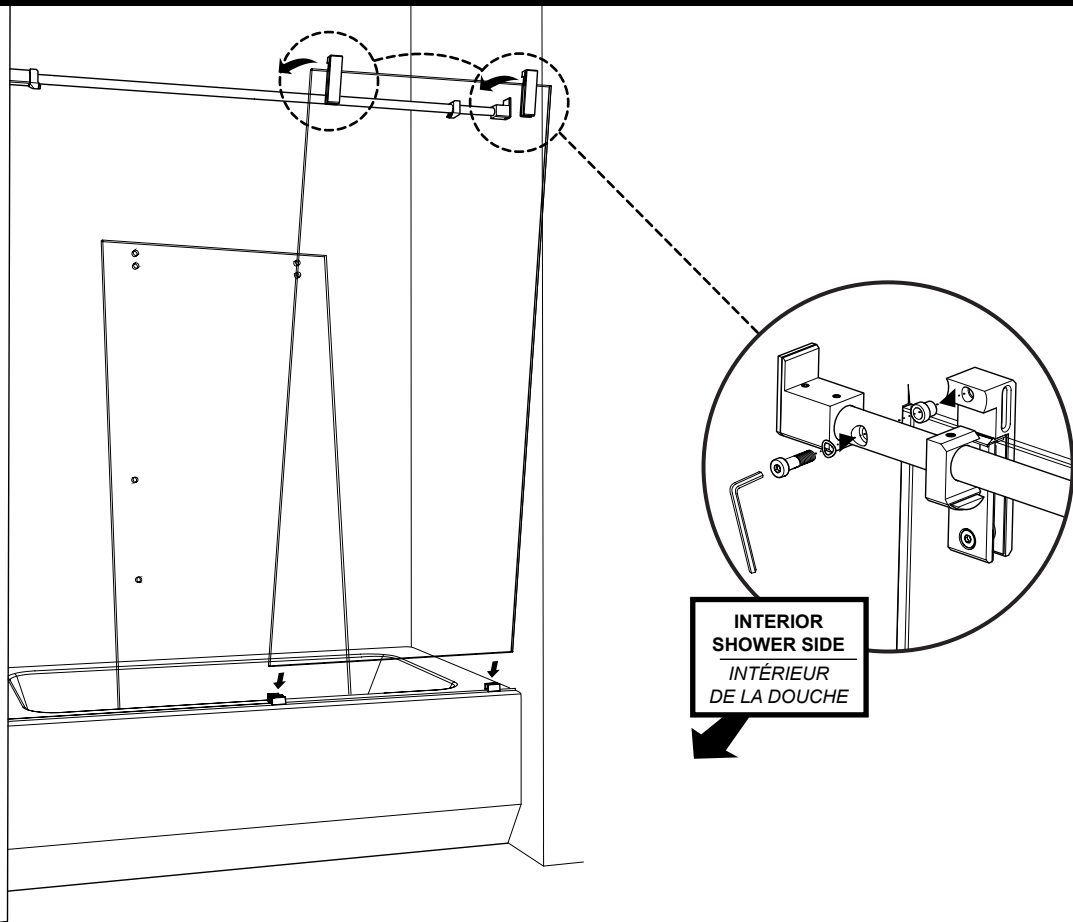

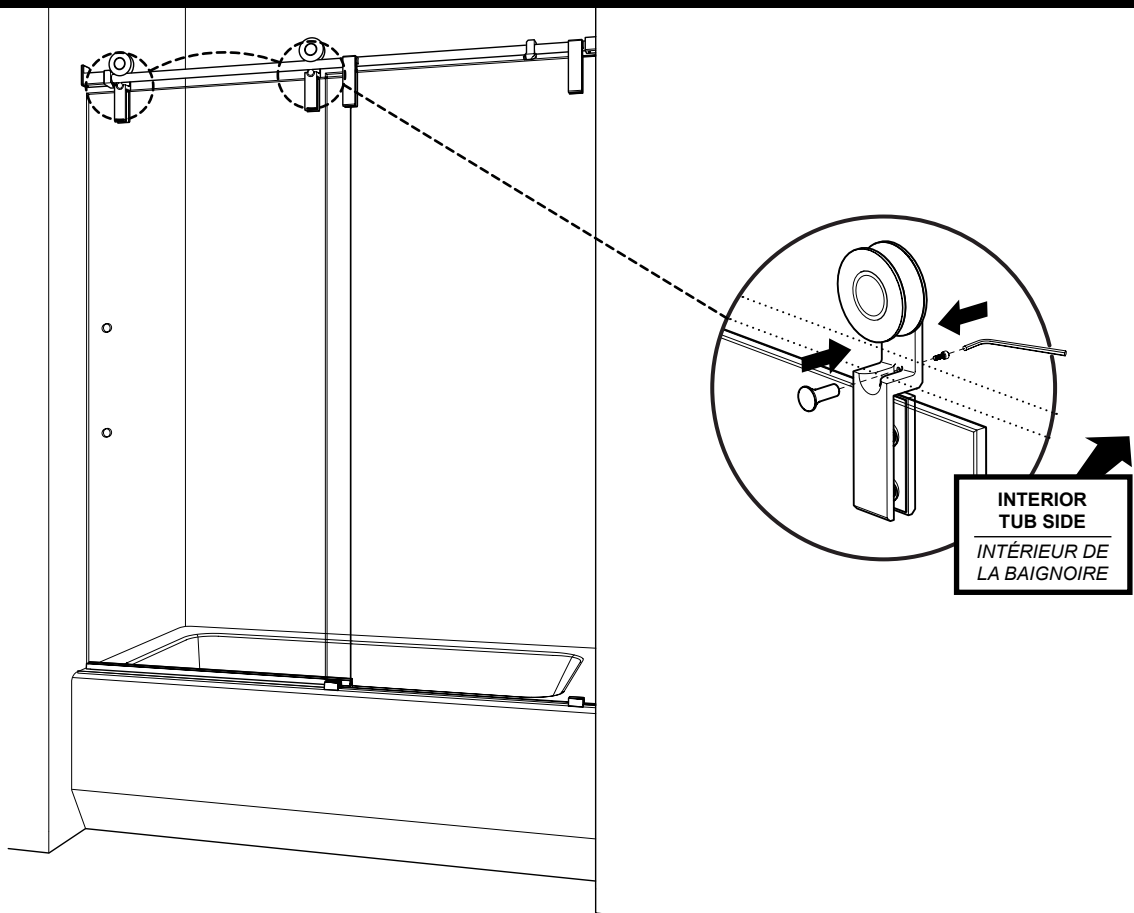
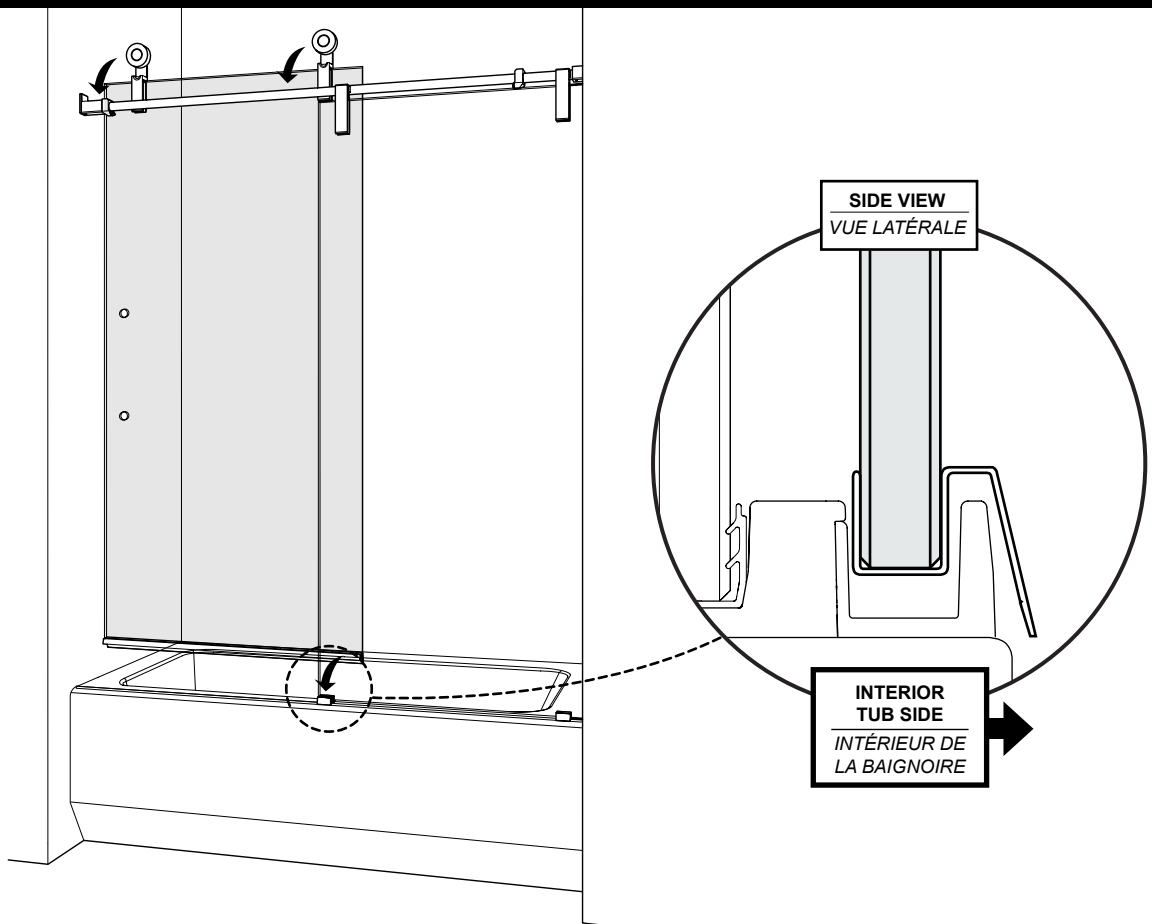

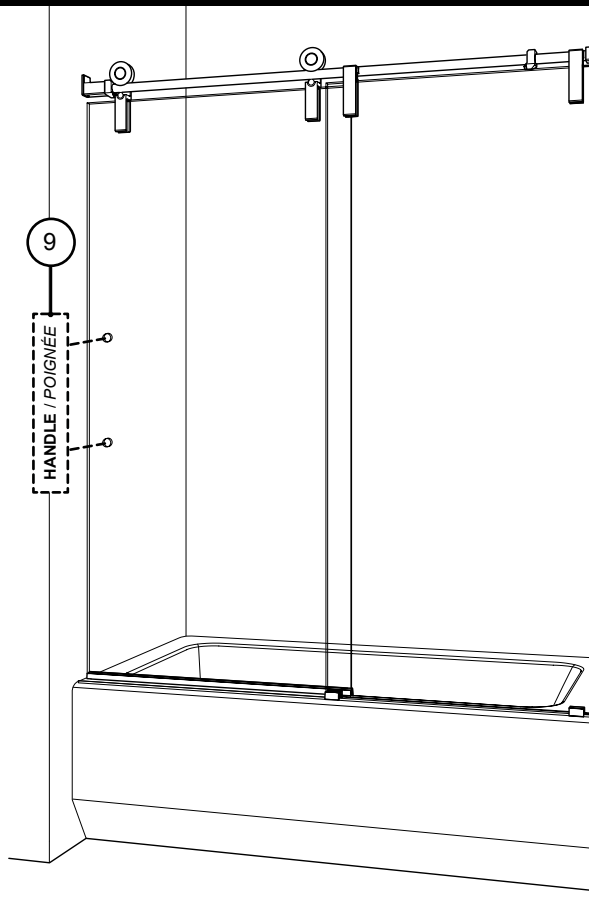

SEE INSTRUCTIONS ENCLOSED WITH HANDLE FOR INSTALLATION PROCEDURES.  
VOIR LES INSTRUCTIONS QUI SONT ENFERMÉS AVEC LA POIGNÉE POUR LES PROCÉDURES D'INSTALLATION.

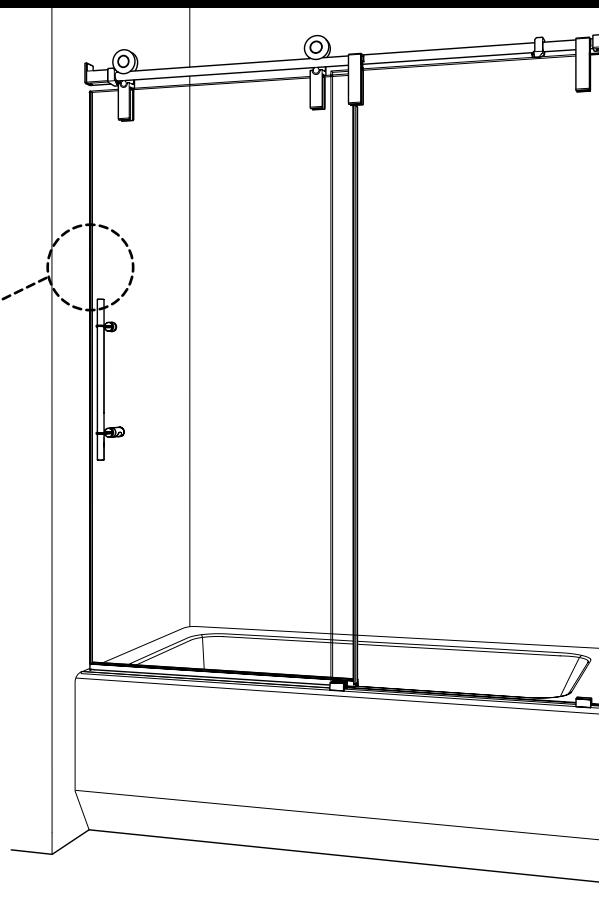
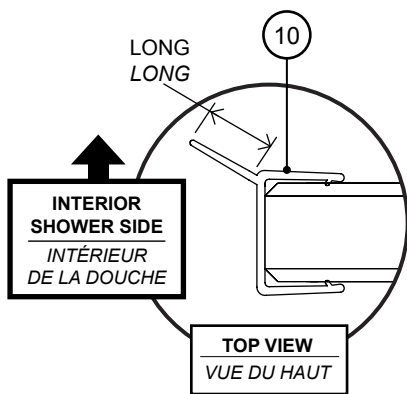

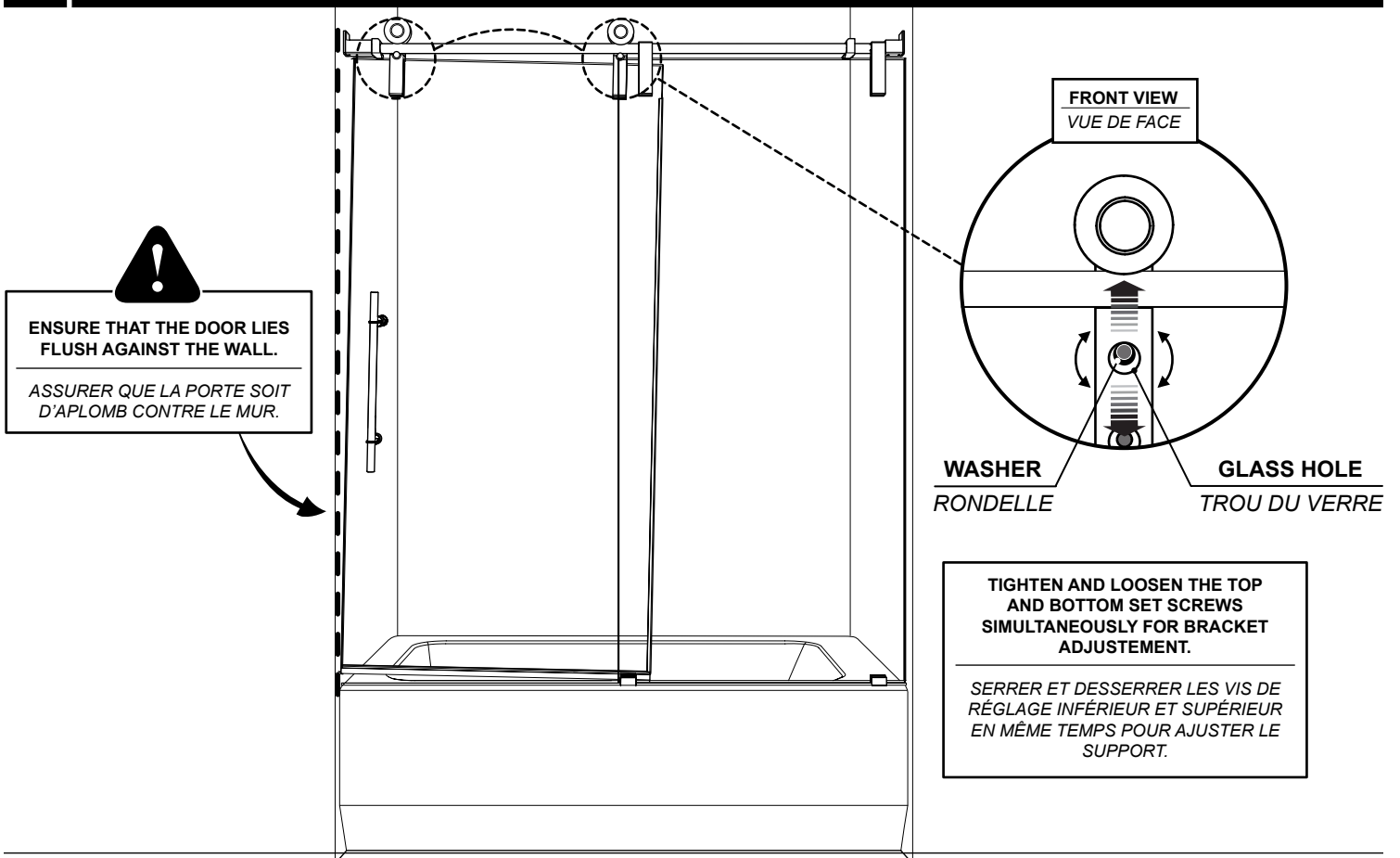
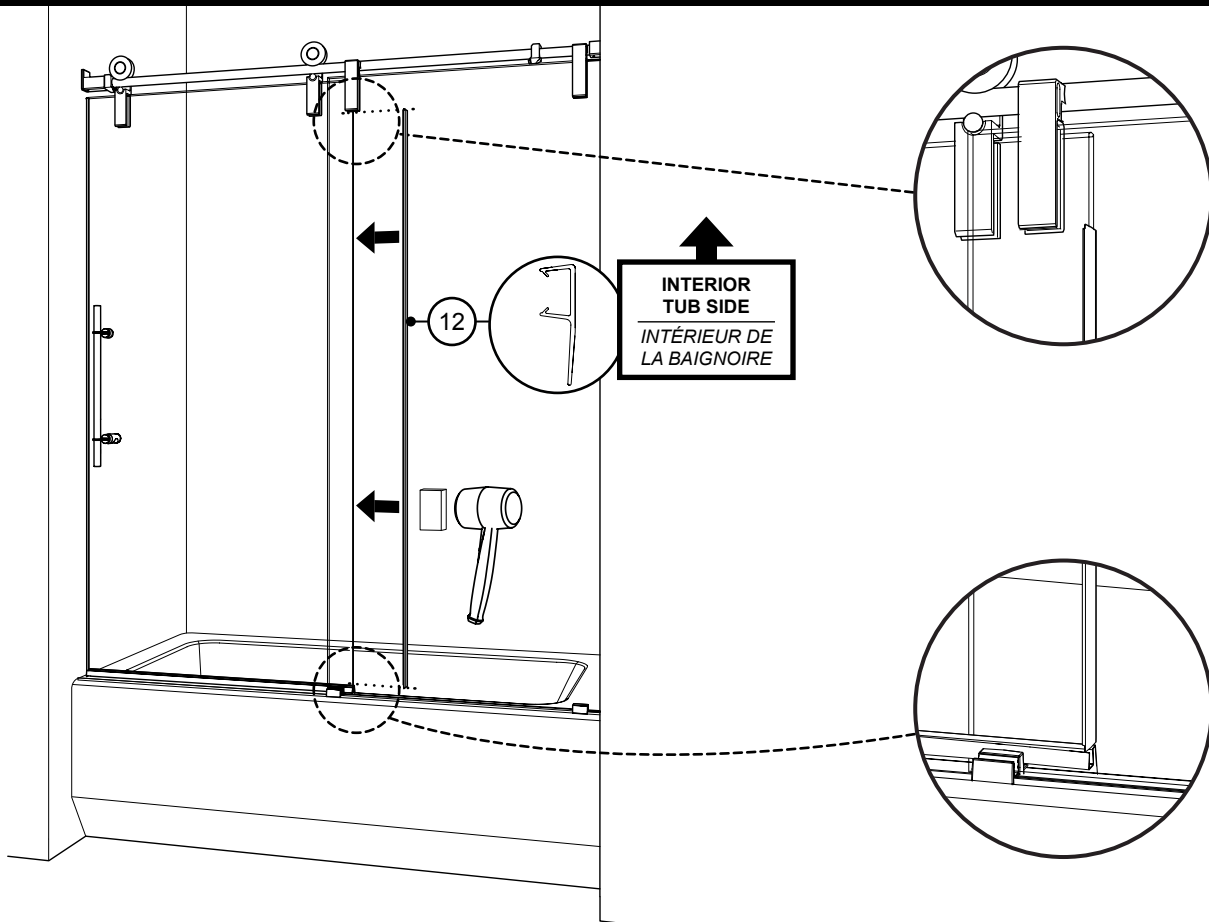

POSITION THE STOPPER SO THAT IT LIES FLUSH AGAINST THE ROLLER WHEN THE DOOR IS IN THE CLOSED POSITION AND THE ADHESIVE DOOR GASKET IS TOUCHING THE WALL.

POSITIONNER LE BUTOIR DE SORTE QU'IL BUTE CONTRE LA ROULETTE LORSQUE LA PORTE EST DANS LA POSITION FERMÉE ET LE JOINT ADHÉSIF TOUCHE LE MUR.

POSITION THE STOPPER SO THAT IT LIES FLUSH AGAINST THE ROLLER AND PREVENTS THE HANDLE FROM HITTING THE FIXED PANEL WHEN THE DOOR IS OPEN.

POSITIONNER LE BUTOIR DE SORTE QU'IL BUTE CONTRE LA ROULETTE ET EMPÊCHE LA POIGNÉE DE FRAPPER LE PANNEAU FIXE LORSQUE LA PORTE EST OUVERTE.

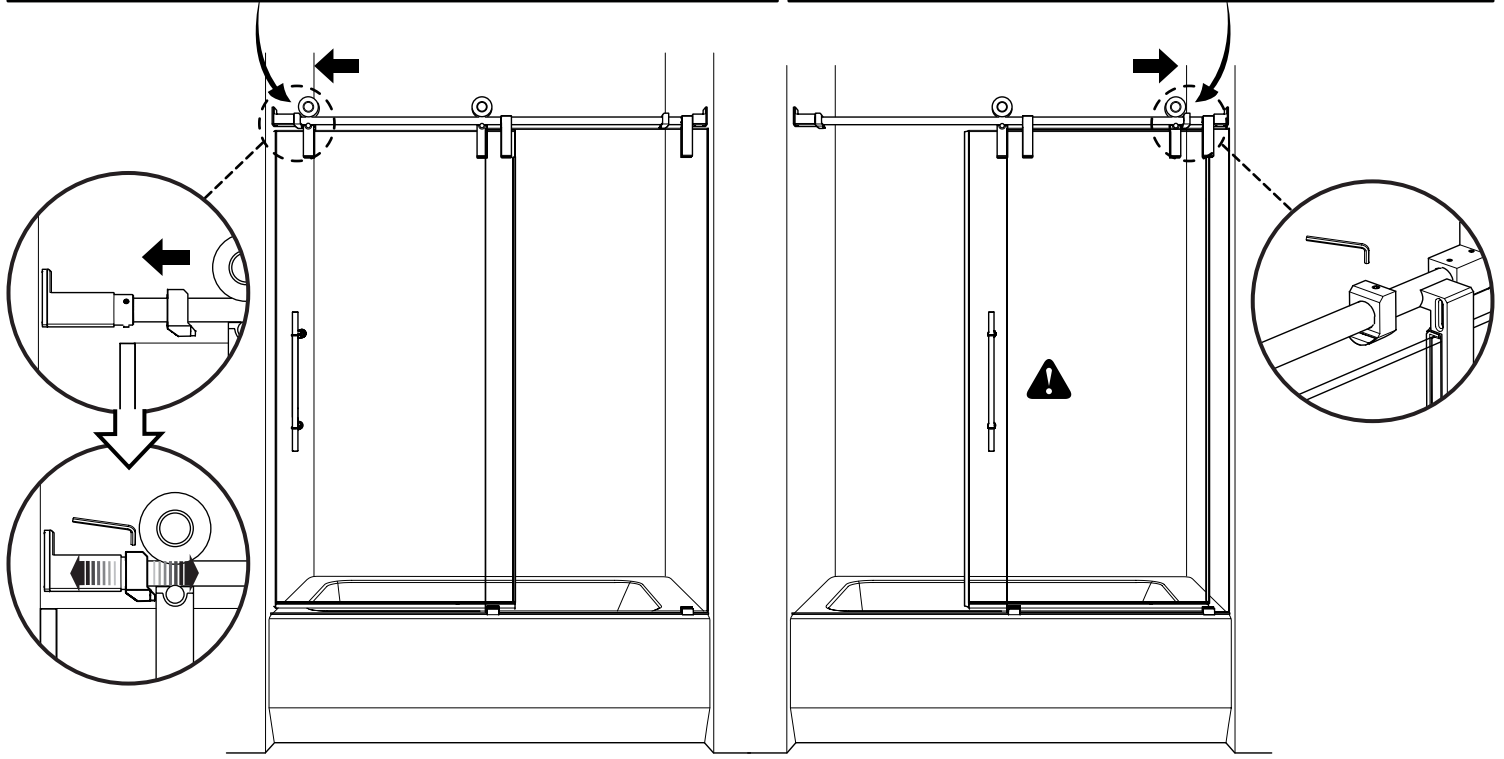

**24** HOURS  
HEURES

